

**Modicon  
Modbus Plus Network  
BM85 Bridge Multiplexer  
User's Guide**

890 USE 103 00

31007492.01

February 2007

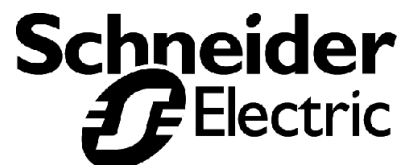



# Preface

---

The data and illustrations found in this book are not binding. We reserve the right to modify our products in line with our policy of continuous product development. The information in this document is subject to change without notice, and should not be construed as a commitment by Schneider Electric.

Schneider Electric assumes no responsibility for any errors that may appear in this document. If you have any suggestions for improvements or amendments or have found errors in this publication, please notify us by e-mail at [techcomm@modicon.com](mailto:techcomm@modicon.com)

No part of this document may be reproduced in any form or by any means, electronic or mechanical, including photocopying, without express written permission of the Publisher, Schneider Electric.



**Caution: All pertinent state, regional, and local safety regulations must be observed when installing and using this product. For reasons of safety and to assure compliance with documented system data, repairs to components should be performed only by the manufacturer.**

MODSOFT® is a registered trademark of Schneider Electric. The following are trademarks of Schneider Electric.

Modbus	Modbus Plus	BM85	SA85
Modicon	984	BP85	SM85

Borland™ is a trademark of Borland International, Inc.

PROCOMM™ is a trademark of Datastorm Technologies, Inc.

DIGITAL® and DEC® are registered trademarks of Digital Equipment Corporation.

IBM® and IBM AT® are registered trademarks and IBM XT™ is a trademark of International Business Machines Corporation.

Microsoft® and MS-DOS® are registered trademarks of Microsoft Corporation.

Copyright © 1995, Schneider Electric  
Printed in U.S.A.



# Contents

---

## Chapter 1

<b>Introducing the BM85 Bridge/Multiplexers .....</b>	<b>1</b>
1.1 Bridge/Multiplexers on Modbus Plus .....	2
1.1.1 The Modbus Plus Network .....	2
1.1.2 The BM85 on Modbus Plus .....	2
1.2 Overview of BM85 Models .....	4
1.2.1 Available Models .....	4
1.2.2 Mounting Methods .....	4
1.2.3 Operating Power .....	5
1.2.4 Configuration Methods .....	5
1.3 Programmable Port Models .....	6
1.4 Configuring the Programmable Models .....	8
1.4.1 Software Development Tool Kit .....	9
1.5 Modbus Port Models .....	10
1.6 Specifications (AC/DC Power Models) .....	12
1.6.1 Bridge/Multiplexer Models for AC/DC Power .....	12
1.6.2 Software Development Tool Kit .....	13
1.6.3 Development Requirement (Supplied by Customer) .....	13
1.7 Specifications (DC/DC Power Models) .....	14
1.7.1 Bridge/Multiplexer Models for DC/DC Power .....	14
1.7.2 Software Development Tool Kit .....	15
1.7.3 Development Requirement (Supplied by Customer) .....	15

## Chapter 2

<b>Device Addressing and Message Routing .....</b>	<b>17</b>
2.1 Modbus Plus Message Routing Paths .....	18
2.1.1 Routing to Programmable Controllers .....	18
2.1.2 Routing to Host Based Network Adapters .....	19
2.1.3 Routing to BM85 Bridge/Multiplexers .....	19
2.2 Modbus Address Conversion .....	20
2.3 Routing Examples .....	22

<b>Chapter 3</b>		
<b>Configuring the Modbus Models</b>	.....	<b>25</b>
3.1	Before You Start	26
3.1.1	Models Covered in This Chapter	26
3.1.2	An Overview of the Configuration Process	26
3.2	Required Equipment	27
3.3	Configuration Checklist	28
3.4	Modbus Port Parameters	29
3.4.1	Information You Will Need	29
3.4.2	Port Type	30
3.4.3	Slave Device Address	31
3.4.4	Communication Parameters	31
3.4.5	Port Priority	31
3.4.6	Link Timeout	32
3.4.7	Modem Booster	34
3.4.8	Modbus Address Map	36
3.5	Configuring the Modbus Ports	40
3.5.1	Connecting Power for the Configuration	40
3.5.2	Setting the Switches	40
3.5.3	Connecting the Terminal	41
3.6	Your Configuration Commands	42
3.6.1	The Default Configuration	43
3.7	Your Configuration Screens	44
3.7.1	Entering Commands Into Your Screens	44
3.7.2	Printing the Configuration	45
3.7.3	Saving the Configuration	45
3.8	Your V1 Screen	46
3.8.1	Your V1 Screen Layout	46
3.8.2	Using the V1 Screen	47
3.9	Your V2 and V3 Screens	48
3.9.1	Your V2 or V3 Screen Layout	48
3.9.2	Using the V2 or V3 Screen	49
3.10	Your V4 Screen	50
3.10.1	Your V4 Screen Layout	50
3.10.2	Using the V4 Screen	51
3.11	Setting the Modbus Plus Address	52
3.12	Setting the RUN Mode	53

3.12.1	When to Set the RUN Mode .....	53
3.12.2	How to Set the RUN Mode .....	53
3.13	Modbus Port Indicator Codes .....	54

## Chapter 4

<b>Configuring the Programmable Models .....</b>	<b>57</b>
4.1 Before You Start .....	58
4.1.1 Models Covered in This Chapter .....	58
4.1.2 An Overview of the Configuration Process .....	58
4.2 Required Equipment .....	59
4.2.1 Equipment for Writing the Application Program .....	59
4.2.2 Equipment For Downloading the Application Program ...	59
4.3 Overview of the Development Software .....	60
4.3.1 Development Software Files .....	60
4.3.2 The README.DOC Information File .....	60
4.3.3 Test and Demonstration Source Files .....	61
4.3.4 Multitasking in Your Application .....	61
4.4 Installing the Development Software .....	62
4.4.1 Default Parameters .....	62
4.4.2 Installation Steps .....	62
4.5 Preparing the BM85 for Downloading .....	64
4.6 Setting the Configuration Switches .....	65
4.7 Setting the Modbus Plus Address .....	66
4.8 Indicator Codes During Downloading .....	67
4.8.1 Normal Download Codes .....	67
4.8.2 Error Codes .....	67
4.9 Setting the RUN Mode .....	68
4.9.1 When to Set the RUN Mode .....	68
4.9.2 How to Set the RUN Mode .....	68

<b>Chapter 5</b>		
<b>Installing the BM85</b>	.....	<b>69</b>
5.1	Installing the BM85 Hardware	70
5.1.1	Mounting the BM85	70
5.1.2	Shelf/Panel Mounted Models	70
5.1.3	Rack Mounted Models	71
5.2	Connecting the Power Cables	74
5.2.1	Connecting AC Power	74
5.2.2	Connecting DC Power	74
5.3	Connecting the Network and Serial Cables	76
5.3.1	Connecting a Single Network Cable	77
5.3.2	Connecting Dual Network Cables	77
5.3.3	Connecting Dual-Cable Units on Single-Cable Networks	77
5.3.4	Connecting Serial Port Cables	77
5.4	Reading the Indicators	78
5.4.1	POWER and READY Indicators	78
5.4.2	Modbus and Serial Port Indicators	78
5.4.3	Modbus Plus Port Status Indicators	79
5.5	Attaching Identification Labels	80
5.5.1	Modbus Plus Port Label	80
5.5.2	Serial Port Parameters Label	81
<b>Appendix A</b>		
<b>Compatible Devices and Cables</b>	.....	<b>83</b>
A.1	Compatible Devices and Cables	84
A.1.1	Abbreviations	84
A.1.2	Making 'Quick Connections'	84
A.1.3	Devices and Cables for Configuring Modbus Ports	85
A.1.4	Cables for Modbus Master Devices	85
A.1.5	Cables for Modbus Slave Devices	85
A.2	Modbus/RS232 Cable Wiring Diagrams	86
A.3	Modbus/RS232 Ports Pinout	87
A.4	RS485 Ports Pinout	88



<b>Glossary</b> .....	<b>89</b>
-----------------------	-----------

<b>Index</b> .....	<b>98</b>
--------------------	-----------

## Figures

Figure 1	BM85 Bridge/Multiplexers on Modbus Plus .....	3
Figure 2	BM85 With Typical RS232/485 Devices .....	7
Figure 3	BM85 With Typical Modbus Devices .....	11
Figure 4	Message Frame Routing Path Field .....	18
Figure 5	Modbus Plus Routing to Single Modbus Slave .....	19
Figure 6	Modbus Plus Routing to Networked Modbus Slave .....	19
Figure 7	Bridge Multiplexer Address Conversion .....	20
Figure 8	Routing Examples .....	22
Figure 9	BM85 Modbus Port Types .....	30
Figure 10	BM85 Modbus Models: Port Configuration Switches .....	40
Figure 11	Typical V1 Screen: Modbus Ports Configuration .....	46
Figure 12	Typical V2 Screen: Modbus Address Map Entries .....	48
Figure 13	Typical V4 Screen: Save or Initialize the Configuration .....	50
Figure 14	BM85 Modbus Models: Modbus Plus Address Switches .....	52
Figure 15	BM85 Programmable Models: Configuration Switches .....	65
Figure 16	BM85 Programmable Models: Modbus Plus Address Switches ..	66
Figure 17	Mounting Dimensions: Shelf/Panel Mount Models .....	72
Figure 18	Mounting Dimensions: Rack Mount Models .....	73
Figure 19	BM85-000 Rear Panel .....	75
Figure 20	BM85C, BM85E, BM85S Rear Panel .....	75
Figure 21	BM85D Rear Panel .....	75
Figure 22	Layout of the Indicators .....	78
Figure 23	Modbus Plus Port Label .....	80
Figure 24	Serial Port Parameters Label .....	81
Figure 25	Modbus/RS232 Cable Wiring Diagrams .....	86
Figure 26	Serial Ports Pinout - Modbus/RS232 .....	87
Figure 27	Serial Ports Pinout - RS485 .....	88



# Chapter 1

## Introducing the BM85 Bridge/Multiplexers

---

- Bridge/Multiplexers on Modbus Plus
- Overview of BM85 Models
- Programmable BM85 Models
- Configuring the Programmable Models
- BM85 Models for Modbus Devices
- Configuring the Modbus Models
- Specifications (AC/DC Power Models)
- Specifications (DC/DC Power Models)

# 1.1 Bridge/Multiplexers on Modbus Plus

---

## 1.1.1 The Modbus Plus Network

Modbus Plus is a local area network designed for industrial control applications. The network enables programmable controllers, host computers, and other devices to communicate throughout the production areas of an industrial plant. It supports up to 64 addressable node devices at a data transfer rate of 1 million bits per second. Single-cable and dual-cable network configurations are available.

User applications include transferring of process control and supervisory messages. Typical networked devices include Modicon programmable controllers that connect to the network through a direct port on the controller or through a communications option. Network adapters connect several types of host computer products to the network.

Multiple networks can be joined through Modicon Bridge Plus nodes. This facilitates the design of time-critical applications in which each network employs only the devices required for the local process.

## 1.1.2 The BM85 on Modbus Plus

The BM85 Bridge/Multiplexer operates as a Modbus Plus node and provides four serial ports that you can configure separately for serial devices in your application. BM85 models are available for single-cable or dual-cable Modbus Plus networks, and for support of RS232, RS485, or Modicon Modbus serial devices.

Figure 1 shows a block diagram of two Modbus Plus networks joined through a BP85 Bridge Plus. Serial devices communicate with the application through the BM85 Bridge/Multiplexers.

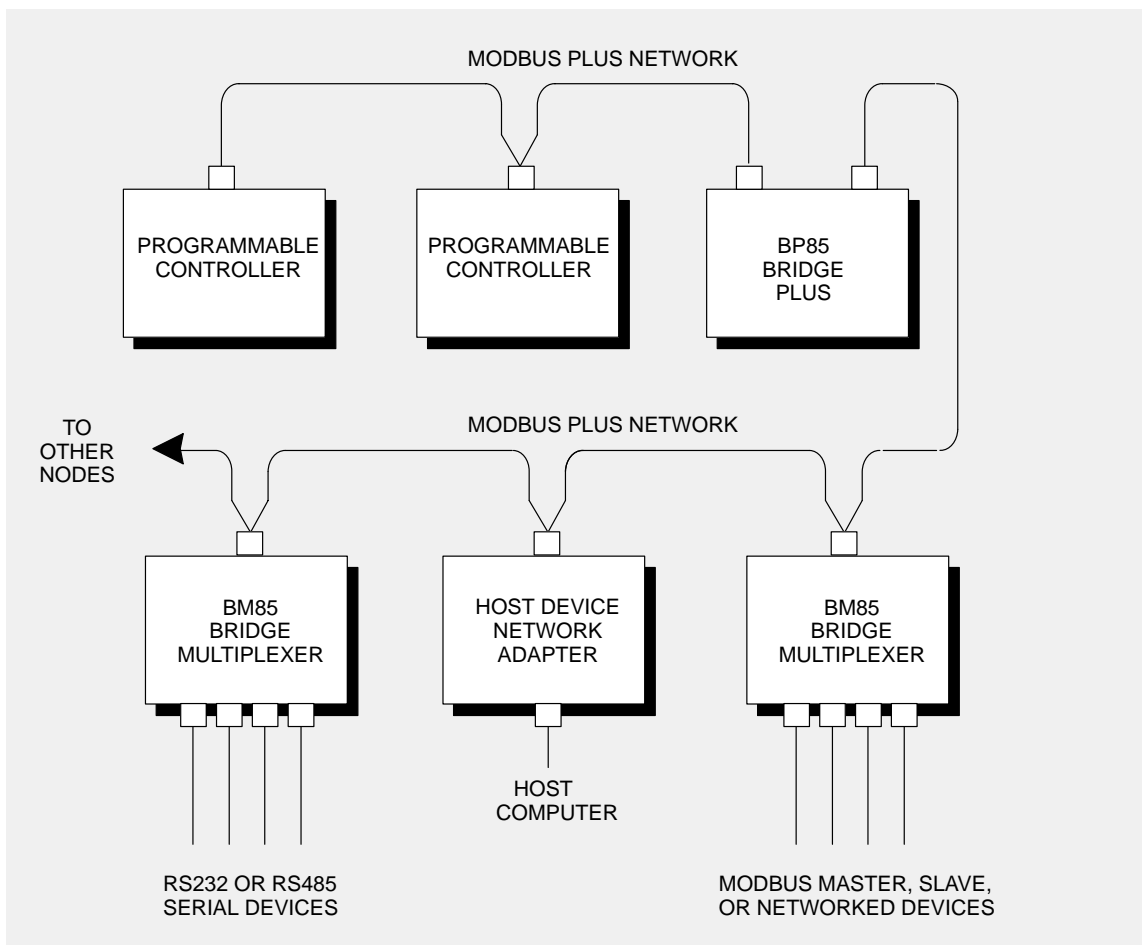

**Figure 1 BM85 Bridge/Multiplexers on Modbus Plus**

Depending on the BM85 model and the types of devices connected at its ports, serial port devices can communicate with:

- Devices at the same serial port
- Devices at other serial ports on the same BM85
- Node devices on the Modbus Plus network
- Devices at serial ports on other BM85s across Modbus Plus.

## 1.2 Overview of BM85 Models

### 1.2.1 Available Models

BM85 models are available for application in single-cable or dual-cable Modbus Plus networks, with a variety of serial port configurations. The characteristics of the BM85 models are:

Part Number	Mounting Method	Operating Power (Nominal)	Modbus Plus Network Cable	Serial Ports	Serial Protocol
NW-BM85-000 (Note 1)	Panel or Shelf	115/230 Vac	Single	Modbus	ASCII or RTU
NW-BM85C002	Panel or Shelf	115/230 Vac or 24 Vdc	Single or Dual	Modbus	ASCII or RTU
NW-BM85D008	19 in Rack	125 Vdc or 24 Vdc	Single or Dual	Modbus	ASCII or RTU
NW-BM85E232 (Note 2)	Panel or Shelf	115/230 Vac or 24 Vdc	Single or Dual	RS232	Programmable, User Defined
NW-BM85D002	19 in Rack	125 Vdc or 24 Vdc	Single or Dual	RS232	Programmable, User Defined
NW-BM85E485 (Note 3)	Panel or Shelf	115/230 Vac or 24 Vdc	Single or Dual	RS485	Programmable, User Defined
NW-BM85S232	Panel or Shelf	115/230 Vac or 24 Vdc	Single or Dual	RS232	Programmable, User Defined
NW-BM85S485	Panel or Shelf	115/230 Vac or 24 Vdc	Single or Dual	RS485	Programmable, User Defined

#### Notes

1. Model NW-BM85-000 has been replaced by NW-BM85C002 for new installations.
2. Model NW-BM85E232 has been replaced by NW-BM85S232 for new installations.
3. Model NW-BM85E485 has been replaced by NW-BM85S485 for new installations.

### 1.2.2 Mounting Methods

For the panel/shelf models, the BM85 bottom surface is fitted with pads for placement on a horizontal shelf. Brackets are supplied for securing the unit to the shelf, or for attaching it to a vertical panel.

Rack-mount models are for installation into a standard 19-inch rack.

## 1.2.3 Operating Power

### AC/DC Models

These models are supplied with a power cable of 6 ft (2 m) length for operation from 110-120 Vac or 220-240 Vac single-phase power. The cable connects to a socket on the rear panel. Grounding is through the cable. The BM85 contains an ac line fuse that is accessible to the user.

All of these models except the BM85-000 can also operate from an external 24 Vdc source. Power connects to a socket on the rear panel. Grounding is through the cable. The dc power source must be fused externally to the BM85.

### DC/DC Models

These models operate from a 125 Vdc or 24 Vdc source. Power connects to a terminal strip on the rear panel. A grounding terminal is provided. The dc power source must be fused externally to the BM85.

## 1.2.4 Configuration Methods

All BM85 models must be configured internally for your application before you can connect them for operation in your application. This is necessary because the BM85's internal configuration specifies how each serial port will operate.

Each model has two sets of rear panel switches. One set assigns the Modbus Plus node address. The other set allows you to either configure the unit or set it into its RUN mode.

### Configuring the Modbus Port Models

For the Modbus serial port models, you configure the unit locally at a serial terminal connected to one of its ports.

### Configuring the Programmable Port Models

For the programmable models, you create an application program externally to the BM85 and then download it to the unit across the Modbus Plus network.

### Setting the RUN Mode

When you have properly completed your configuration of the BM85, you can set it into its RUN mode for operation in your application.



**Caution: Do not connect the BM85 into your application environment unless you have set its internal configuration. Do not connect it to your network or to any device unless you have set its switches properly for configuring or running.**

## 1.3 Programmable Port Models

Part Number	Mounting Method	Operating Power (Nominal)	Modbus Plus Network Cable	Serial Ports	Serial Protocol
NW-BM85E232	Panel or Shelf	115/230 Vac or 24 Vdc	Single or Dual	RS232	Programmable, User Defined
NW-BM85D002	19 in Rack	125 Vdc or 24 Vdc	Single or Dual	RS232	Programmable, User Defined
NW-BM85E485	Panel or Shelf	115/230 Vac or 24 Vdc	Single or Dual	RS485	Programmable, User Defined
NW-BM85S232	Panel or Shelf	115/230 Vac or 24 Vdc	Single or Dual	RS232	Programmable, User Defined
NW-BM85S485	Panel or Shelf	115/230 Vac or 24 Vdc	Single or Dual	RS485	Programmable, User Defined

The four serial ports on these models are programmable by the user to support custom RS232 or RS485 serial devices.

These models must be downloaded with an executable BM85 application program across the Modbus Plus network. The downloaded image contains all of the internal operating code used by the BM85, including communication protocols for the serial ports: handshaking, protocol translation between ports, message packaging, buffer space, data conversion, and error handling. Each serial port indicator is individually programmable to show the port's status in the application.

The image can contain all of the serial port parameters (for example, baud rates and parity) as fixed parameters. Alternatively the image could provide a local protocol (default parameters and a menuing system) for the user to locally configure the serial ports through a terminal at one of the ports.

In addition to standard serial devices, Modbus master or slave devices could be attached at RS232 serial ports if the user-defined code includes a Modbus protocol handler.

You can create the BM85 application program on an IBM PC/AT or 100% compatible, using Modicon BM85 software development tools. These are available from Modicon Customer Service and are shipped separately from the BM85. Details of the development tools are provided in Section 1.4.1.

The BM85 can operate as a fully-programmed processor in the user application. The unit can locally manage processes at its serial ports,



initiating or responding to Modbus Plus messages as needed for higher-level status reporting and control. Library functions are provided in the BM85 development software for creating multiple tasks within the BM85's application program, and for assigning and arbitrating the tasks.

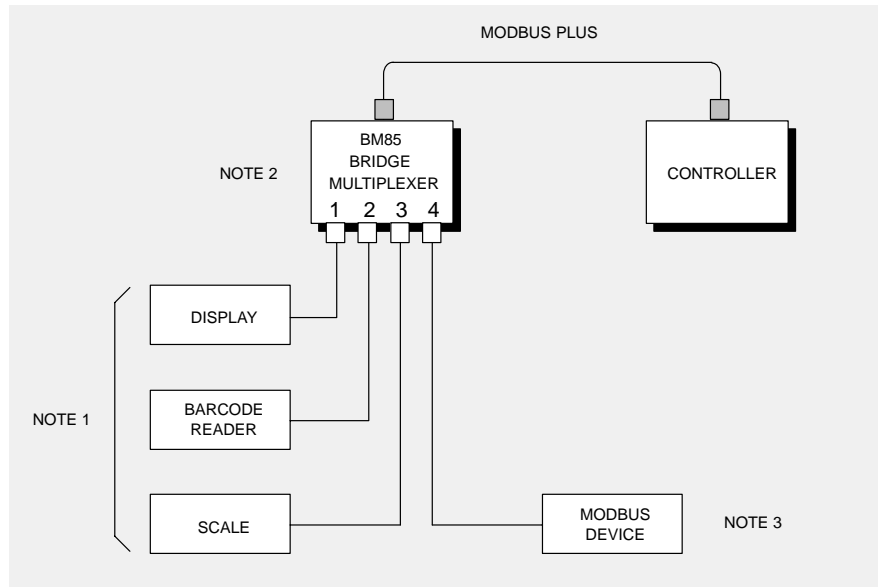

**Figure 2 BM85 With Typical RS232/485 Devices**

Figure 2 summarizes the typical layout of devices at the serial ports.

**Notes**

1. RS232 or RS485 compatible devices are required for the respective BM85 models. RS232 and RS485 devices cannot be mixed on the same BM85.
2. Incoming/outgoing access to devices in the application is defined by the BM85's internal code, programmed by the user and downloaded to the BM85 across Modbus Plus.
3. Modbus master or slave devices can be used if the user-defined code includes a Modbus protocol handler.

## 1.4 Configuring the Programmable Models

---

### **Developing the Application**

When you configure the custom-programmable models, you must develop the entire BM85 application as a file and then download it into the BM85. This includes the operating code for message handling, buffer allocation, protocol conversion, and your serial port parameters.

You can create the application program on an IBM PC/AT or compatible, using Modicon software development tools that are shipped separately from the BM85. These require the use of a Borland C/C++ development environment which must be supplied by the user.

In addition to its internal configuration, the BM85's Modbus Plus node address must be assigned. This is done in a set of hardware switches on the rear panel.

### **Downloading the Application**

The compiled application can then be downloaded to the BM85 using a utility supplied with the Modicon tools. The download host can be the same computer that was used for developing the application, or a separate computer.

For downloading, the host must contain a Modicon SA85 Modbus Plus network adapter (for an IBM AT-compatible host) or Modicon SM85 adapter (for an IBM Micro Channel-compatible host). If a network connection is available for the BM85 in the vicinity of the host node, you can download and debug your application locally. Otherwise, you can download it to the BM85 at its installation site.

When the user application has been stored in the BM85, it will be retained by the BM85 after power is removed. If the parameters are correct for the intended installation site, the unit can be transported to the site and installed there without reconfiguration.

## 1.4.1 Software Development Tool Kit

A listing of files supplied in the BM85 Software Development kit is provided in Section 4.3.1. The development tools include:

- A Borland C/C++ run-time startup routine
- An object library of BM85 utility routines, including functions for managing multiple tasks in the BM85 application
- A Modbus Plus data transfer utility routine
- A header file containing function prototypes
- A compiled demonstration program, with source code, showing examples of the use of functions in a typical application
- Test utilities, including source code, that exercise BM85 hardware
- The download utility for loading the application to the BM85.

The development tool kit is supplied on MS-DOS compatible disks. Ordering information is given below.

Contact	Telephone
Modicon Customer Service	1-800-468-5342 (North America) 1-508-975-5001 (International)

Part Number	Description
SR-BM85-S00	BM85 Software Development Kit (Note 1)
SR-BM85-S0R	BM85 Software Support Renewal (Note 2)

### Notes

1. The kit (SR-BM85-S00) includes documentation describing how to:

- Install the development software
- Compile and link your application
- Download your application to the BM85.

2. The kit includes 90 days of BM85 software development technical support service provided by Modicon Customer Service. The support renewal (SR-BM85-S0R) extends the BM85 software development technical support service beyond the initial 90-day period.

## 1.5 Modbus Port Models

---

Part Number	Mounting Method	Operating Power (Nominal)	Modbus Plus Network Cable	Serial Ports	Serial Protocol
NW-BM85-000	Panel or Shelf	115/230 Vac	Single	Modbus	ASCII or RTU
NW-BM85C002	Panel or Shelf	115/230 Vac or 24 Vdc	Single or Dual	Modbus	ASCII or RTU
NW-BM85D008	19 in Rack	125 Vdc or 24 Vdc	Single or Dual	Modbus	ASCII or RTU

The four serial ports on these models support Modicon Modbus serial devices. These models provide the conversion between Modbus addresses and the required address formats for routing messages to other Modbus ports or to Modbus Plus nodes.

You must configure these models offline before connecting them to Modbus Plus or to any devices in your application. You can do this by connecting a serial terminal to one BM85 port, setting a switch to allow local setup of the parameters, and applying power to the BM85. The BM85 displays menus on the terminal for setting up the configuration.

Each port is separately configurable. You assign four kinds of parameters for each port:

- Port type - Modbus master, 'silent master', slave, or network
- Protocol - ASCII, RTU
- Communication parameters - baud rate, stop bits, parity mode
- Address mapping - for conversion between Modbus addresses and Modbus Plus routing.

In addition to the serial port configurations, the BM85's Modbus Plus node address must be assigned. This is done in a set of hardware switches on the rear panel.

When the configuration has been completed, the internal parameters will be retained by the BM85 after power is removed. If the parameters are correct, the unit can be transported to the installation site and installed there without reconfiguration.

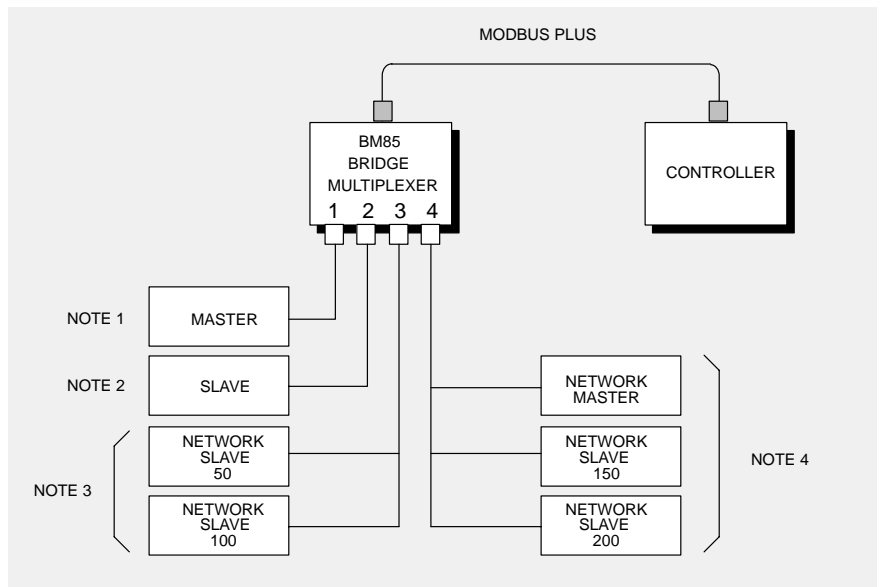

**Figure 3 BM85 With Typical Modbus Devices**

Figure 3 summarizes the typical layout of devices at the Modbus ports.

### Notes

1. This is an example of a single Modbus master device. The device can access devices on other ports at the same BM85, as well as devices across Modbus Plus.
2. This is an example of a single Modbus slave device. The device is accessible from devices on other ports at the same BM85, as well as from devices across Modbus Plus.
3. This is an example of a Modbus network with multiple slave devices. Any device on the port is accessible from devices on other ports at the same BM85, and from devices across Modbus Plus.
4. This is an example of a Modbus network with one master device and one or more slave devices. The master device can access devices on the same port, on other ports at the same BM85, and devices across Modbus Plus. The slave devices are accessible only to the Master on the same port.

## 1.6 Specifications (AC/DC Power Models)

### 1.6.1 Bridge/Multiplexer Models for AC/DC Power

Description	Name	BM85 Modbus Plus Bridge/Multiplexer
	Part Number	NW-BM85-000, NW-BM85C002 NW-BM85E232, NW-BM85S232 NW-BM85E485, NW-BM85S485
Mounting Method	Horizontal Surface	Platform or shelf, with included mounting brackets
	Vertical Surface	Panel, with included mounting brackets
Physical Characteristics	Height	2.59 in (66 mm)
	Width	11.50 in (292 mm), unit only
		14.08 in (358 mm), with mounting brackets
	Depth	8.30 in (211 mm)
Weight	5.5 lbs (2.5 kg) net	
	6.5 lbs (3.0 kg) shipping	
AC Power (All AC/DC Models)	Requirements	115/230 Vac $\pm 15\%$ . 47 ... 63 Hz 10 W
	Access	Rear panel power connector with ON/OFF switch
	Fuse	1.0 A, 3 AG SB, internal
DC Power (not available on NW-BM85-000)	Requirements	24 Vdc $\pm 15\%$ , 10 W
	Access	Rear panel power connector
	Fuse	1.0 A external, customer supplied
Environmental	Temperature	0 ... 60 degrees C, operating
		-40 ... +80 degrees C, storage
	Humidity	0 ... 95%, non-condensing
	Altitude	10,000 ft (3 km), maximum
	EMI, Radiated Susceptibility	MIL STD 461B RS03
EMI, Conducted Susceptibility	MIL STD 461B CS03	
Network Connections	NW-BM85-000	Single-cable network only
	NW-BM85C002, NW-BM85E232, NW-BM85S232, NW-BM85E485, NW-BM85S485	Single- or dual-cable network

Serial Connections	All Models	Four DB9S
Serial Parameters	NW-BM85-000, NW-BM85C002	Modbus protocol, ASCII/RTU 300-19200 baud odd/even/no parity 1 or 2 stop bits
	NW-BM85E232, NW-BM85S232	User defined protocol, RS232 50-19200 baud
	NW-BM85E485, NW-BM85S485	User defined protocol, RS485 50-19200 baud

## 1.6.2 Software Development Tool Kit

Contact	Telephone
Modicon Customer Service	1-800-468-5342 (North America) 1-508-975-5001 (International)

Part Number	Description
SR-BM85-S00	BM85 Software Development Kit, 3.5 in and 5.25 in HD disks, Documentation, 90 day Technical Support
SR-BM85-S0R	BM85 Software Technical Support Renewal

## 1.6.3 Development Requirement (Supplied by Customer)

Development System	IBM PC/AT Compatible, 486 or higher recommended, to support Development Environment
Development Environment	Borland C/C++ Compiler version 3.1 or higher, BM85 applications use Large model
Download System	IBM PC/AT Compatible host with SA85 Adapter, or IBM Micro Channel host with SM85 Adapter 486 or higher recommended 4 MB RAM minimum

# 1.7 Specifications (DC/DC Power Models)

## 1.7.1 Bridge/Multiplexer Models for DC/DC Power

Description	Name	BM85 Modbus Plus Bridge/Multiplexer
	Part Number	NW-BM85D002, NW-BM85D008
Mounting Method	Vertical	Standard 19 in Rack
Physical Characteristics	Height	3.47 in (88 mm)
	Width	19.00 in (483 mm), mounting panel
		18.26 in (464 mm), hole centers
	Depth	9.15 in (232 mm)
	Weight	5.5 lbs (2.5 kg) net
6.5 lbs (3.0 kg) shipping		
Power	Requirements	105 to 140 Vdc, or 24 Vdc $\pm$ 15%
	Access	Rear panel screw terminals
	Input Current	0.41 A at 125 V dc
	Inrush Current	6 A typical at 125 V dc
	Ground Leakage	1 mA at 140 V dc
	Fuse	External, customer supplied
Environmental	Temperature	0 ... 60 degrees C, operating
		-40 ... +80 degrees C, storage
	Humidity	0 ... 95%, non-condensing
	Altitude	10,000 ft (3 km), maximum
	EMI, Radiated Susceptibility	27 ... 500 mHz, 10 V/m IEC 801-3, level 3 IEEE/ANSI C37.90.2, 1987
	Surge Withstand, Fast Transient	$\pm$ 2 kV (1 kV on I/O), V3300 generator into 50 ohms. Corresponds to $\pm$ 4 kV (2 kV on I/O) into open circuit. IEC 801-4, level 3 IEEE/ANSI C37.90.1 2.3, 1989
	Surge Transients	2 kV IEC 801-5, level 3
	Electrostatic Discharge	8 kV, ten discharges IEC 801-2, level 3
Surge Withstand, Oscillatory Wave	2.5 kV IEEE 472 IEEE/ANSI C37.90.1 2.2, 1989	



Network Connections	All Models	Single- or dual-cable network
Serial Connections	All Models	Four DB9S
Serial Parameters	NW-BM85D008	Modbus ASCII/RTU protocol 300–19200 baud odd/even/no parity 1 or 2 stop bits
	NW-BM85D002	User defined protocol, RS232 50–19200 baud

## 1.7.2 Software Development Tool Kit

Contact	Telephone
Modicon Customer Service	1-800-468-5342 (North America) 1-508-975-5001 (International)

Part Number	Description
SR-BM85-S00	BM85 Software Development Kit, 3.5 in and 5.25 in HD disks, Documentation, 90 day Technical Support
SR-BM85-S0R	BM85 Software Technical Support Renewal

## 1.7.3 Development Requirement (Supplied by Customer)

Development System	IBM PC/AT Compatible, 486 or higher recommended, to support Development Environment
Development Environment	Borland C/C++ Compiler version 3.1 or higher, BM85 applications use Large model
Download System	IBM PC/AT Compatible host with SA85 Adapter, or IBM Micro Channel host with SM85 Adapter 486 or higher recommended 4 MB RAM minimum



# Chapter 2

## Device Addressing and Message Routing

---

- Modbus Plus Message Routing Paths
- Modbus Address Conversion
- Routing Examples

## 2.1 Modbus Plus Message Routing Paths

A single Modbus Plus network can have up to 64 addressable node devices, with each device having a unique address of between 1 and 64. Multiple networks can be joined through Bridge Plus devices. Devices address each other across Bridge Plus devices by specifying routing paths of five bytes, with each byte representing an address on the next network. This routing method allows nodes in other networks to be addressed up to four networks away from the originating node.

The routing path is imbedded in the Modbus Plus message frame as it is sent from the originating node:

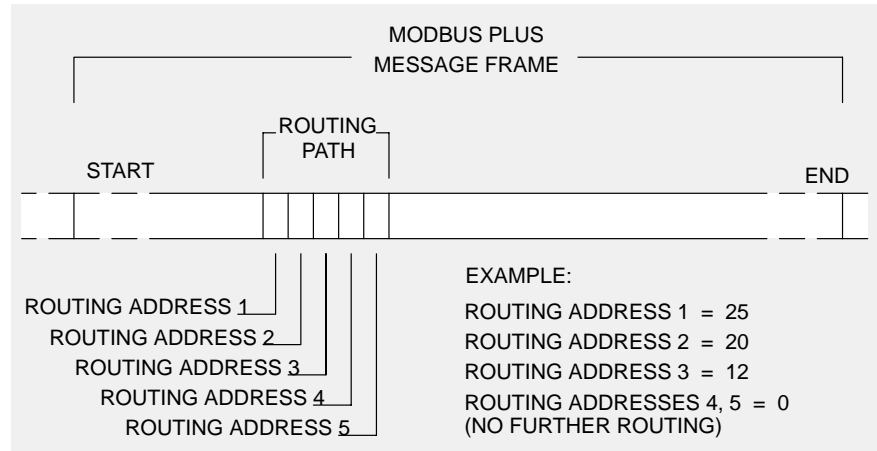

Figure 4 Message Frame Routing Path Field

Figure 4 is an example of message routing to a programmable controller through three networks that are joined by Bridge Plus node devices. The message will first be routed to node 25, a Bridge Plus on the local network. That node forwards the message on to a Bridge Plus at address 20 on the second network. The second Bridge Plus forwards the message to its final destination, node address 12 on the third network. The zero contents of bytes 4 and 5 specify no further message routing.

### 2.1.1 Routing to Programmable Controllers

For programmable controllers, the last non-zero byte in the message routing specifies the network node address of the controller (1 to 64).

## 2.1.2 Routing to Host Based Network Adapters

For host based network adapters, the byte following the adapter's network node address specifies a task number (1 ... 8) to which the message is assigned. Subsequent bytes are not checked by the adapter, and are available for custom use to the application - for example, for message counts or status information.

## 2.1.3 Routing to BM85 Bridge/Multiplexers

### Routing to Serial Ports on BM85 Programmable Models

For the programmable models, the user application stored in the BM85 defines the addressing between Modbus Plus and the serial ports.

### Routing to a Single Slave Device on BM85 Modbus Models

For a single slave device at a Modbus port, two bytes are used to address the device. The next-to-last non-zero byte addresses the BM85 node (1 ... 64). The last non-zero byte specifies the Modbus port (1 ... 4), and therefore specifies the single slave device.

Figure 5 shows an example of routing to a single slave device.

BP85 ADDRESS (1 ... 64)	BM85 ADDRESS (1 ... 64)	BM85 PORT (1 ... 4)	ZERO	ZERO
-------------------------------	-------------------------------	---------------------------	------	------

Figure 5 Modbus Plus Routing to Single Modbus Slave

### Routing to a Networked Slave Device on BM85 Modbus Models

For a slave device on a Modbus network at a Modbus port, three bytes are used to address the device. The third byte from the last non-zero byte addresses the BM85 node (1 ... 64). The next-to-last non-zero byte specifies the Modbus port (1 ... 4). The last non-zero byte specifies the Modbus address of the slave device (1 ... 247).

Figure 6 shows an example of routing to a networked slave device.

BP85 ADDRESS (1 ... 64)	BM85 ADDRESS (1 ... 64)	BM85 PORT (1 ... 4)	SLAVE ADDRESS (1 ... 247)	ZERO
-------------------------------	-------------------------------	---------------------------	---------------------------------	------

Figure 6 Modbus Plus Routing to Networked Modbus Slave

## 2.2 Modbus Address Conversion

### Programmable Port Models

For the programmable models, the user application stored in the BM85 defines the addressing conventions to be used between the serial ports and Modbus Plus. The application program must define the routing between serial ports, as well as the paths to Modbus Plus nodes.

### Modbus Port Models

For the Modbus port models, address conversion between Modbus and Modbus Plus addresses is provided internally as described below. Examples are shown in Section 2.3.

When the BM85 receives a message at a Modbus port, the Modbus address (1 ... 255) is compared to an internal address map for that port. You define the map table during your BM85 configuration. It can hold up to 64 Modbus addresses, each pointing to a five-byte routing path.

*If an address match is found in the table, the five routing path bytes are applied to the message. If the first byte is in the range 1 ... 64, the message is routed out on Modbus Plus. If the first byte is zero, the message goes to a Modbus port (1 ... 4) specified in byte two. If that port has a single slave device, the remaining three bytes are zeros. If the port has a network of slave devices, byte three specifies the slave address.*

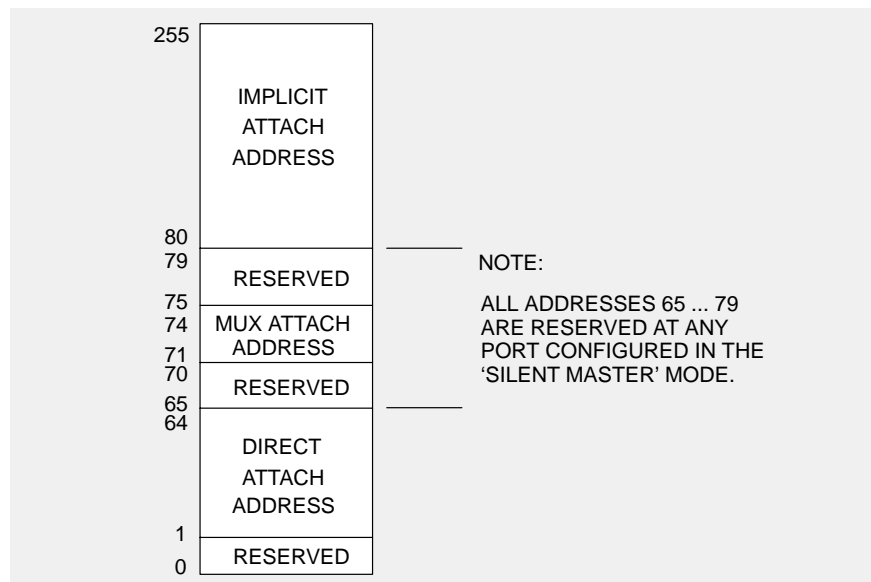

Figure 7 Bridge Multiplexer Address Conversion

If a match is not found in the table, conversion proceeds as in Figure 7.

If the address is in the range 1 ... 64 (Direct Attach Address), the message is routed to the specific node address 1 ... 64 on the local Modbus Plus network.

If the address is in the range 71 ... 74 (MUX Attach Address), the message is routed to a single device at one of the local Modbus ports. Addresses 71 ... 74 specify ports 1 ... 4, respectively.

If the address is in the range 80 ... 255 (Implicit Attach Address), it will be divided by 10 within the BM85. The quotient and remainder of the division will become the first two bytes of the five-byte routing path. This method allows two levels of Modbus Plus addressing: the quotient byte specifies a Bridge Plus address on the local network, and the remainder byte specifies the destination node on the second network. The final three bytes in the routing path will always be zeros.

### **Silent Master Port Addressing**

A Modbus port can be configured as a Silent Master network port. In this configuration, one Modbus master device and one or more slave devices can be connected to the port. The master device can address its own network's slave devices directly. It can also address devices at other ports on the same BM85, or devices across Modbus Plus.

Special considerations are needed for addressing in this configuration. The intent is to avoid address conflicts between slave addresses at the local port and other addresses that may exist elsewhere.

The slave devices on the Silent Master port must have unique addresses. They must not be the same as a node address (1 ... 64) on the BM85's local Modbus Plus network. They must also not exist as entries in the address mapping table stored within the BM85. The Modbus addresses in the master's queries to the slave devices must not map beyond the Silent Master port -- neither to any routing on Modbus Plus, nor to another port on the BM85.



**Note:** Reserved addresses are *not* to be used in user applications.

When the port is configured as a Master port, addresses 65 ... 70 and 75 ... 79 are reserved. Addresses 71 ... 74 are available for use.

When the port is configured as a Silent Master port, addresses 65 ... 79 are reserved.

The Bridge Multiplexer will respond with a Modbus exception response to any message addressed to a reserved address.

## 2.3 Routing Examples

Figure 8 illustrates message routing across two networks.

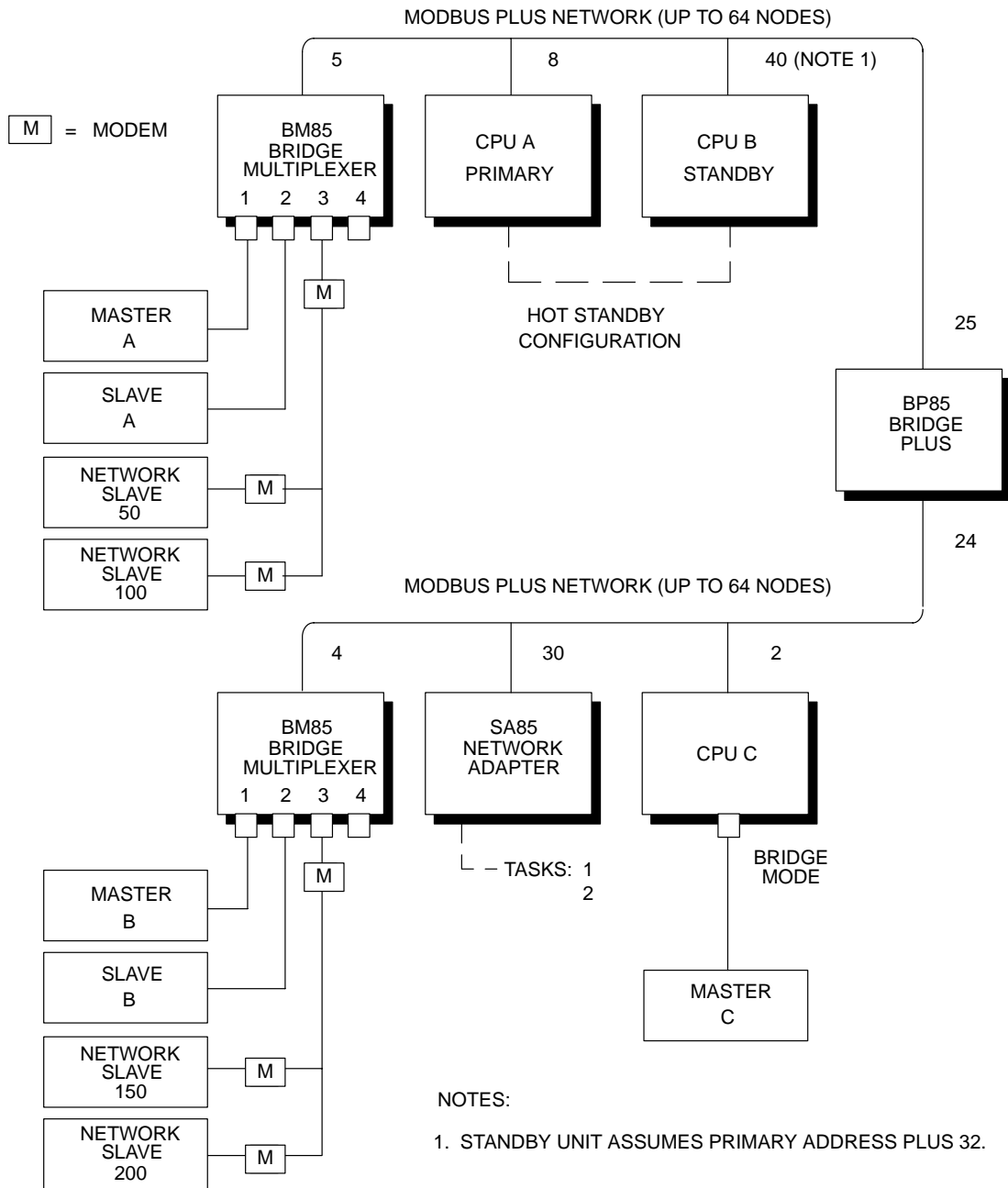

Figure 8 Routing Examples



Here are examples of routing between peer, master, and slave devices.

From	To	Routing Path				
CPU A (Primary)	Slave A	5	2	0	0	0
	50	5	3	50	0	0
	CPU C	25	2	0	0	0
	SA85 (Task 1)	25	30	1	0	0
	Slave B	25	4	2	0	0
	200	25	4	3	200	0
CPU C	SA85 (Task 2)	30	2	0	0	0
	Slave B	4	2	0	0	0
	200	4	3	200	0	0
	CPU A (Primary)	24	8	0	0	0
	CPU B (Standby)	24	40	0	0	0
	100	24	5	3	100	0
SA85	Slave B	4	2	0	0	0
	150	4	3	150	0	0
	CPU C	2	0	0	0	0
	CPU A (Primary)	24	8	0	0	0
	50	24	5	3	50	0

If Masters A, B, and C are programming panels such as the Modicon P230, they can attach to various devices using Direct, Implicit, or MUX addressing, or mapped routing:

From	To	Address		Routing Method	
Master A	CPU A (Primary)	8	Attach	Direct	8 0 0 0 0
	Slave A	72	Attach	MUX	Internal Path
	CPU C	252	Attach	Implicit	252/10 = 25 2 0 0 0
	50	50	Attach	Mapped	0 3 50 0 0
	200	200	Attach	Mapped	25 4 3 200 0
Master B	CPU C	2	Attach	Direct	2 0 0 0 0
	Slave B	72	Attach	MUX	Internal Path
	CPU A (Primary)	248	Attach	Implicit	248/10 = 24 8 0 0 0
	200	200	Attach	Mapped	0 3 200 0 0
	50	100	Attach	Mapped	24 5 3 50 0
Master C	CPU A (Primary)	248	Attach	Implicit	248/10 = 24 8 0 0 0
	CPU B (Standby)	71	Attach	Mapped	24 40 0 0 0
	Slave A	72	Attach	Mapped	24 5 2 0 0
	Slave B	73	Attach	Mapped	4 2 0 0 0
	150	74	Attach	Mapped	4 3 150 0 0



# Chapter 3

## Configuring the Modbus Models

---

- Before You Start
- Required Equipment
- Configuration Checklist
- Modbus Port Parameters
- Configuring the Modbus Ports
- Your Configuration Commands
- Your Configuration Screens
- Your V1 Screen
- Your V2 and V3 Screens
- Your V4 Screen
- Setting the Modbus Plus Address
- Setting the RUN Mode
- Modbus Port Indicator Codes

## 3.1 Before You Start

---

### 3.1.1 Models Covered in This Chapter

This chapter covers the configuration process for the following models:

Part Number	Mounting Method	Operating Power (Nominal)	Modbus Plus Network Cable	Serial Ports	Serial Protocol
NW-BM85-000	Panel or Shelf	115/230 Vac	Single	Modbus	ASCII or RTU
NW-BM85C002	Panel or Shelf	115/230 Vac or 24 Vdc	Single or Dual	Modbus	ASCII or RTU
NW-BM85D008	19 in Rack	125 Vdc or 24 Vdc	Single or Dual	Modbus	ASCII or RTU

### 3.1.2 An Overview of the Configuration Process

The BM85 requires the setup of internal configuration parameters for each port that you will use in your application. The unit contains a non-volatile memory that stores the port configurations, even when operating power is removed.

You must set the port configurations using a serial terminal (or a PC with a terminal emulation program) connected to one of the BM85 ports. The BM85 does not have to be connected to the Modbus Plus network. A switch is provided on the BM85 to enable the unit to be configured. If the unit is already installed at its site, you can configure it there. You can also do the configuration prior to installing the unit at its site, then transport the configured unit to the site and install it.

You must also set the Modbus Plus node address into a set of switches on the BM85 rear panel.



**Caution:** You must complete the internal configuration of the BM85 before making the unit active in your application, both on the Modbus Plus network and at its serial ports.

**If you are installing a BM85 that was previously configured for another application, another network, or a different node, the unit will still be retaining its previous configuration setup. You must not connect the unit into the current application and apply operating power to the unit until you have reconfigured it for the current application.**

## 3.2 Required Equipment

---

To configure the Modbus port parameters, you will need either of the following devices:

- DEC VT100 or equivalent terminal, with a compatible serial cable
- IBM AT or XT or equivalent computer product, running a VT100 terminal emulation program such as PROCOMM PLUS, with a compatible serial cable.

A listing of compatible terminals and cables is provided in Appendix A.

Some terminal emulation programs, such as PROCOMM PLUS, allow you to store the keystrokes you use into a 'script' file on your disk. This allows you to duplicate your future configurations from the disk, without having to key in the parameters. Refer to the documents for your emulation program for further details.

If you have a printing terminal, or a printer connected to your emulator, you can print a hard copy record of your BM85 configuration. This will be helpful in documenting your configuration. Typically, you can use your terminal's 'Print Screen' (or equivalent) key to print the hard copy.

## 3.3 Configuration Checklist

---

You have a specific sequence of actions for configuring your BM85. Use these items as your checklist:

1. **Select a terminal and cable.** Refer to Appendix A for a listing of compatible terminal devices and cables. Select a terminal and cable that you will use for the configuration.
2. **Determine the Modbus port parameters.** Refer to Section 3.4, *Modbus Port Parameters*. Determine the parameters you want to use for each Modbus port:
  - Port Type
  - Slave Device Address
  - Communication Parameters
  - Port Priority
  - Link Timeout
  - Modem Booster
  - Modbus Plus Address Table.
3. **Configure the Modbus ports.** Turn off all power to the BM85. Refer to Section 3.5, *Configuring the Modbus Ports*.

Connect your terminal to the port you will use for configuration. Start your terminal and any emulation program you are using.

Set the switches to allow the configuration, and power up the BM85. Use the configuration screens and keyboard to configure the unit.
4. **Set the Modbus Plus address.** Refer to Section 3.11, *Setting the Modbus Plus Address*. Set the BM85 rear panel address switches to its node address on your Modbus Plus network.
5. **Set the RUN Mode.** Refer to Section 3.12, *Setting the RUN Mode*. Turn off all power to the BM85. Set its rear panel switch to the RUN mode. Connect the unit to the Modbus Plus network and to the Modbus devices at its installation site before reapplying power.

## 3.4 Modbus Port Parameters

---

### 3.4.1 Information You Will Need

You will need the following information for each port that you will use in your application. Parameters are explained in the sections indicated.

**Port Type (see Section 3.4.2)**

Modbus Master

Modbus Slave

Modbus Network

Modbus 'Silent Master' Network

**Slave Device Address (see Section 3.4.3)**

1 ... 247

**Communication Parameters (see Section 3.4.4)**

Baud Rate: 50 ... 19200

Stop Bits: 1 or 2

Parity Mode: Even, Odd, or None

Communication Mode: ASCII or RTU

Note: Models NW-BM85C002 and NW-BM85D008 do not have a Stop Bits setting. These models default to 8 data bits with 1 Stop Bit.

**Port Priority (see Section 3.4.5)**

1 ... 4

**Link Timeout (see Section 3.4.6)**

1 ... 3000 multiples of 100 milliseconds

**Modem Booster (see Section 3.4.7)**

Yes or No

**Modbus Plus Address Table (see Section 3.4.8)**

A routing table with up to 64 entries for translating Modbus addresses to Modbus Plus network routing paths.

### 3.4.2 Port Type

#### Master

A port to which a single Modbus master device such as an IBM PC or Modicon P230 Programmer is to be connected. In Figure 9, port 1 is an example.

#### Slave

A port to which a single Modbus slave device such as a programmable controller is to be connected. In Figure 9, port 2 is an example.

#### Network

A port to which multiple Modbus slave devices are to be connected. In Figure 9, port 3 is an example.

#### Silent Master Network

A port to which one Modbus master device and one or more slave devices are to be connected. In Figure 9, port 4 is an example.

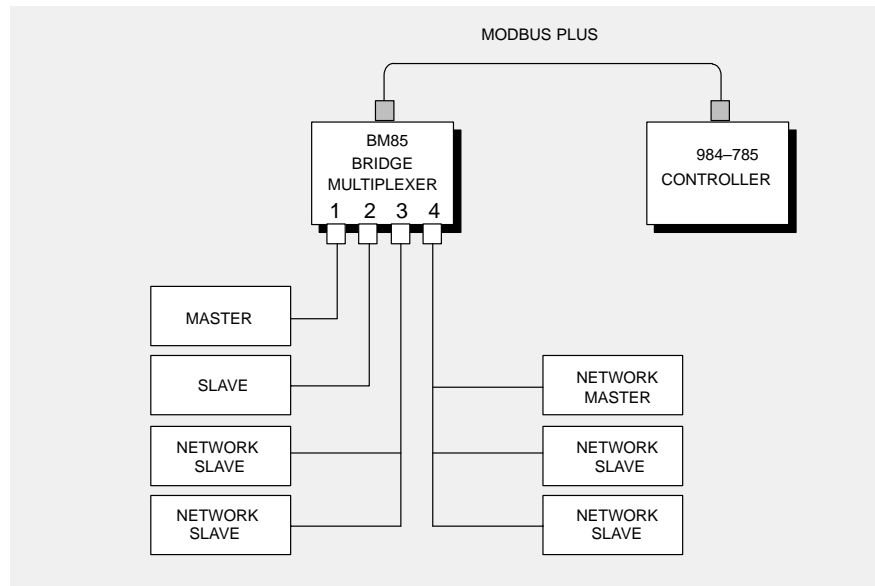

Figure 9 BM85 Modbus Port Types



### 3.4.3 Slave Device Address

If the port is to be configured as a Modbus single slave device port, a slave device address must be assigned to the port in the range 1 ... 247 decimal.

The address is part of the configuration of a port to which a single slave device is attached. This address is not applicable to Modbus master devices, as they do not use a device address. It is also not applicable to Modbus networked devices, as multiple devices can exist on the port.

### 3.4.4 Communication Parameters

You must set each port's parameters to communicate with the Modbus device or devices attached to the port. Refer to the documents for your devices to determine their parameters. Modicon Modbus devices generally support the following parameters:

- RTU (8-bit binary) mode, 9600 baud, 8 data bits, 1 or 2 stop bits, even/odd/no parity
- ASCII (character) mode, 9600 baud, 7 or 8 data bits, 1 or 2 stop bits, even/odd/no parity.

Models NW-BM85C002 and NW-BM85D008 do not have a Stop Bits setting. These models default to 8 data bits with 1 Stop Bit.

### 3.4.5 Port Priority

#### The Purpose of the Parameter

The BM85 services the four Modbus ports in a sequence that you can establish during configuration by setting the Port Priority parameter.

#### Setting the Parameter

You set the sequence by assigning a priority to each port in the range 1 ... 4, with 1 being the highest priority. The port that is assigned priority 1 will be the first port that is serviced on power up.

### 3.4.6 Link Timeout

#### The Purpose of the Parameter

Link timeout is the maximum time you will allow for a slave device to respond to a command issued at the BM85 Modbus slave port. In your application, if the timeout value is exceeded, a 'slave device down' error code will be returned by the program function initiating the command to the device.

If the timeout value is too short, slower devices may not have time to respond normally to their commands, resulting in apparent errors at the device. If the value is too long, and a device fails to respond, your application will have to wait until the timeout occurs before handling the device condition or using the port again.

A value should be set to handle the slowest device at the port, without excessive delay. The value should accommodate the sum of the following:

- serial communication time
- slave device processing time: for example, controller scan time
- BM85 processing time for port transactions, approximately 4 ms.

#### Setting the Parameter

You set each port's timeout parameter as a value in the range 1 ... 3000. The timeout value represents multiples of 100 milliseconds.

For example, a parameter of 10 specifies a link timeout of 10 x 100 ms, or one second.

## Timeout Examples

Here are some examples for setting the link timeout value. Each is based on a Modbus message transaction of 256 bytes to the port device and 256 bytes from the device.

- Parameters: RTU, 9600 baud, 1 start, 8 data, no parity, 1 stop.  
Serial communication time:  $(10 \text{ bits})/9600 = 1.04 \text{ ms/character}$ ,  
 $267 \text{ ms}$  for 256 bytes (RTU mode sends one character per byte).  
Slave controller scan time: 100 ms.  
BM85 time: 4 ms.  
Total time:  $(267 + 267 + 100 + 4) = 638 \text{ ms}$ .  
Use a link timeout value of 10 (1000 ms).
- Parameters: ASCII, 9600 baud, 1 start, 8 data, 1 parity, 1 stop.  
Serial communication time:  $(11 \text{ bits})/9600 = 1.15 \text{ ms/character}$ ,  
 $294 \text{ ms} \times 2 = 588 \text{ ms}$  for 256 bytes (2 chars/byte for ASCII).  
Slave controller scan time: 100 ms.  
BM85 time: 4 ms.  
Total time:  $(588 + 588 + 100 + 4) = 1280 \text{ ms}$ .  
Use a link timeout value of 15 (1500 ms).
- Parameters: ASCII, 300 baud, 1 start, 8 data, 1 parity, 2 stop.  
Serial communication time:  $(12 \text{ bits})/300 = 40 \text{ ms/character}$ ,  
 $10.24 \text{ seconds} \times 2 = 20.48 \text{ s}$  for 256 bytes (2 chars/byte for ASCII).  
Slave controller scan time: 100 ms.  
BM85 time: 4 ms.  
Total time:  $(20.48 \text{ s} + 20.48 \text{ s} + 100 \text{ ms} + 4 \text{ ms}) = 41.06 \text{ s}$ .  
Use a link timeout value of 450 (45000 ms, or 45 s).

### 3.4.7 Modem Booster

#### How the Parameter Applies to the BM85

The Modem Booster applies to BM85 Modbus ports that will be configured as Network ports. You will need this information for any port you will be using as a Modbus Network port.

The parameter does not apply to a port that is being configured as a single Master or Slave device port. You can bypass the information below for any port you will be using as a single Master or Slave port.

#### The Purpose of the Parameter

The Modem Booster parameter determines how the BM85 will handle Modbus commands to networked slave devices at a Modbus port.

When the BM85 receives a command that is addressed to a slave device at a Modbus network port, a response is expected from the slave device. Two methods are available for handling the response, defined by the function code in the command issued by the master. The two kinds of commands are:

- **‘Suspend’ Transactions (Function Code 126)** With this type of command, the slave device will send a response after it completes the action requested in the command. The master device waits for the response, and therefore other commands on the Modbus network cannot be processed until the slave’s action has been completed and its response received. Other transactions intended for the port must remain pending until that time. Some commands, such as ‘start’ and ‘search’ commands from a Modicon P230 programming panel to a slave controller on the Modbus network, can take a relatively long time for processing in the controller, in the range of 15 seconds to 2 minutes.
- **‘Polling’ Transactions (Function Code 13)** With this type of command, the slave will send an acknowledgement of receipt of the command, and must be polled later by the master device to determine if the requested action has been completed. The command acknowledgement frees the Modbus network for processing messages to other devices on the port. The BM85 will poll the slave device periodically to determine if the command action has been completed. It will then send the final response to the originating device.

The Modem Booster parameter allows you to specify which of the two methods will be used at the BM85 Modbus port.

### Setting the Parameter

You can select 'No' or 'Yes' for the Modem Booster parameter at any serial port. The parameter will have the following effect:

If you select 'No' for this parameter, incoming commands with function code 126 or 13 are passed directly to the slave device at the port. If the command is function code 126, the slave response will be returned to the originator of the Modbus command after the slave has completed the requested action, or when it returns an exception response indicating that it cannot complete the action.

Selecting 'Yes' causes the second type of response (function code 13) to be used. If the command specifies function code 126, the BM85 will perform a conversion to function code 13 before sending the command to the slave device. The BM85 will then automatically handle the polling of the slave device until the command action is completed. It will return the final response to the originator of the command. The polling process is handled by the BM85 transparently to the originator.

### Modem Booster Example

A P230 programming panel connected to a Modbus Plus networked controller can access a slave controller that is part of a Modbus network at a BM85 port. The P230 panel can remotely interrogate, program, and start the slave controller.

If the Modem Booster parameter is set, the P230 can issue a command with function code 126. The BM85 converts the function code and sends the converted command to the slave. The BM85 then handles polling of the slave, returning a response to the P230 when the slave device's action is completed.

To the originating device, the response appears as the one from the slave for function code 126. During this time, however, normal network transactions can continue between other devices in the user application and the other slave devices on the BM85 port's Modbus network.



**Note: For Modicon 584 Controllers** The Modem Booster will not function with 584 controllers that are in SAFE84 mode. Function code 13 is not recognized by those controllers in that mode. You should select the Modem Booster 'No' option for a BM85 port that will have 584 controllers connected to that port's Modbus network.

### 3.4.8 Modbus Address Map

The BM85 maintains four internal Modbus Address Map tables for routing the Modbus messages received at its four Modbus ports. Each port has a table that can hold up to 64 entries that you specify during configuration.

- the location in the table at which you want to place the entry
- a one-byte Modbus address in the range 1 ... 255 decimal
- a five-byte routing path.

Each table entry specifies how you will want a Modbus address received at the Modbus port to be converted into a five-byte routing path to the destination device in your application. Routing can be made to a Modbus Plus node on the local network or on a remote network. Messages can also be routed to a device on another port of the BM85.

When a Modbus message is originated from a device at one of its Modbus ports, the BM85 searches the Modbus Address Map table for that port to find a match between the message's Modbus address and a Modbus address stored in the table. The actions taken if a match is found, or if a match is not found, are described below and on the following pages.

#### If a Match is Found

If a match is found, the five bytes of mapped routing from the table entry will be applied to the message, and it will be sent out using that routing. Here are five examples of how the Modbus Address Map table can be used to develop routing paths for Modbus messages:

Table Location	Modbus Address	Five-Byte Routing Path
01	47	8 0 0 0 0
02	182	20 14 0 0 0
03	27	20 22 5 0 0
04	33	0 3 0 0 0
05	125	0 4 99 0 0

- Entry 01** is an example of routing to node 8 on the local Modbus Plus network. If the Modbus message contains the destination address 47, a match is found in the table. The BM85 will apply the routing path 8, 0, 0, 0, 0 to the message. The message is acted upon by the application program in the device at node address 8.

- **Entry 02** is an example of routing through a Bridge Plus to a programmable controller at node address 14 on a second network. Finding a match for Modbus address 182, the BM85 applies the routing path 20, 14, 0, 0, 0 to the message. It will be sent to node 20 on the current Modbus Plus network, a Bridge Plus. It will be routed through the bridge to node 14 on the second network.
- **Entry 03** shows how the type of device at the destination can determine the routing of a message. Finding a match for Modbus address 27, the BM85 applies the routing path 20, 22, 5, 0, 0 to the message. The message is sent to node 20 on the current network, a Bridge Plus. The message is routed through the bridge to node 22 on the next network. The type of device at node 22 determines how further routing is applied. If node 22 is another Bridge Plus, the message is routed to node 5 on a third network. If node 22 is an SA85 or SM85 Network Adapter, the message is accepted by the adapter and posted to application task 5 running in the adapter.
- **Entry 04** shows routing to a single slave device on another port of the same BM85. Finding a match for Modbus address 33, the BM85 will apply the routing path 0, 3, 0, 0, 0 to the message. The zero in the first byte specifies internal routing to another Modbus port. The second byte specifies port 3. Port 3 must have only a single slave device connected, as the remaining bytes are zeros.
- **Entry 05** shows routing to a networked slave device on another port of the same BM85. If the Modbus message contains an address of 125, the routing path 0, 4, 99, 0, 0 is applied. The zero in the first byte specifies internal routing to another Modbus port. The second byte specifies port 4. The third byte specifies slave device address 99 on the network at that port. The remaining bytes must contain zeros.

### If a Match is Not Found

If an address match is not found in the table, the Modbus address in the message will be converted by the BM85 into a routing path using the methods described below. The resulting path can be either to the Modbus Plus network, or to a single slave device connected to another Modbus port of the Bridge Multiplexer.

- **Address Range 1 ... 64** If the message contains an address in the range 1 ... 64 decimal, it will be sent to the Modbus Plus node at that address on the local Modbus Plus network.

For example, if the message contains Modbus address 8, it will be sent to the Modbus Plus device at node 8.

- **Address Range 65 ... 70** These addresses are reserved and must not be used.
- **Address Range 71 ... 74** If the message contains an address in the range 71 ... 74, it will be addressed to a single Modbus slave device at one of the BM85 Modbus ports. Addresses 71 ... 74 specify ports 1 ... 4, respectively.

For example, if the message contains address 74, it will be routed to the device at port 4.

Each of the addresses 71 ... 74 specifies only a single port, and cannot be used to address a Modbus network of devices at a port. To address a device on a Modbus network, the Modbus Address Map table must be used.

- **Address Range 75 ... 79** These addresses are reserved and must not be used.
- **Address Range 80 ... 255** If the message contains an address in the range 80 ... 255, it will be converted to a routing path as follows.

First, the address will be divided by 10. The quotient and remainder of the division will become the first two bytes of the five byte routing path. The remaining three bytes of the routing path will always be zeros.

For example, if the message the address 150, the resulting routing path will be: 15, 0, 0, 0, 0. The first byte (15) is the quotient of the division; the second byte (0) is the remainder. The message will be sent to node 15 on the local Modbus Plus network.

If the message address is 163, the resulting routing path will be: 16, 3, 0, 0, 0. The message will be routed to Modbus Plus node address 16 on the local network. Further routing depends upon the type of device at that node address. If node 16 is a Bridge Plus, the message will be routed through the bridge to node 3 on the next network. If node 16 is an SA85 Adapter, the message will be accepted by that device and posted to its application task 3.

Using this method, up to 18 Modbus Plus nodes can be addressed, each with a node address 8 ... 25. If these nodes are Bridge Plus devices, nodes 8 ... 24 can pass messages through to nodes 1 ... 9 on a second network (with quotients 8 ... 24, and remainders 1 ... 9). Node 25 can pass messages to nodes 1 ... 5 on that network.



### **Silent Master Port Considerations**

In the Silent Master port configuration, one Modbus master device and one or more Modbus slave devices can be connected as a Modbus network at the port. This allows the master device to address the slave devices directly, as well as to address other devices at other ports on the same BM85 or across Modbus Plus.

In the Silent Master configuration, the slave devices on the port must have unique addresses in your application. They must not be the same as a node address (1 ... 64) on the BM85's local Modbus Plus network. They must also not exist as entries in the Modbus Address Map table that you setup within the BM85.

The Modbus addresses in the master's queries to the slave devices at the Silent Master port must not map beyond the port -- not to any routing path on Modbus Plus, nor to another port on the BM85.

## 3.5 Configuring the Modbus Ports

### 3.5.1 Connecting Power for the Configuration

Refer to the installation chapter in this guide for connecting power to your BM85. Connect the source of AC or DC power to the BM85. Do not turn on the power to the BM85 until you set the Modbus port configuration switches and connect the configuration terminal. The switch settings will be sensed when power is applied.

### 3.5.2 Setting the Switches

The BM85 power should be set off at this time. Switches are located on the BM85 rear panel. Figure 10 shows the switch positions and setup.

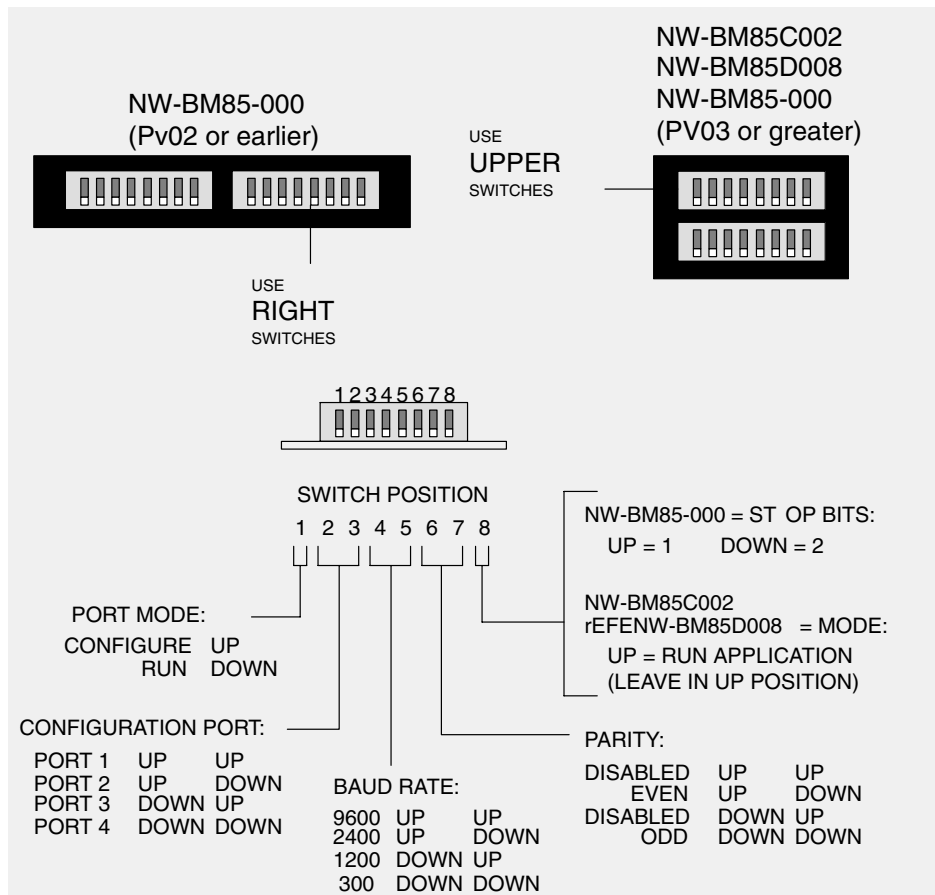

Figure 10 BM85 Modbus Models: Port Configuration Switches

### **Set the CONFIGURE Mode**

Set switch 1 to the CONFIGURE position (UP).

### **Define the Configuration Port**

Switches 2 and 3 determine the port connector to be used for connecting the serial terminal. Set them for the port you want to use.

### **Set the Configuration Port Parameters (NW–BM85–000)**

Set switches 4 ... 8 to match the terminal's baud rate, parity mode, and stop bits. The port always uses 8 data bits for configuration.

### **Set the Configuration Port Parameters (NW–BM85C002, D008)**

Set switches 4 ... 7 to match the terminal's baud rate and parity mode. The port always uses 8 data bits and 1 stop bit for configuration. Always leave switch 8 in its RUN (UP) position. The BM85 will not run unless switch 8 is UP.

## **3.5.3 Connecting the Terminal**

### **What You Will Need**

You will need a serial terminal and cable of the types listed in *Compatible Devices and Cables*, in Appendix A.

### **Connect the Terminal**

The BM85 power should be off at this time. Connect the terminal to the port you are using for configuration. Set the terminal's communication parameters to match those of the BM85. Power up your terminal, and start any emulation program you are using. Your terminal should be running and ready, before you apply power to the BM85.

### **Apply Power to the BM85**

When you have set the configuration switches, and your terminal is ready, apply power to the BM85.

The configuration port's indicator should blink at one second intervals, showing that the configuration mode is active. Your terminal should display the MODBUS PORTS CONFIGURATION (V1) screen.

Your configuration screens and keyboard commands are described starting at Section 3.6.

## 3.6 Your Configuration Commands

Each screen shows the commands that are valid for that screen. You can use either upper or lower case when entering a command.

Command	Action	Range
V	Select a configuration screen or Help screen	1 ... 8
P	Select a port to be configured	1 ... 4
N	Enter a Modbus slave device address	1 ... 247
T	Enter the port type	M = Master S = Slave N = Network X = Silent Master Network
B	Enter the baud rate	50, 300, 1200, 1800, 2000, 2400, 3600, 4800, 7200, 9600, 19200
S	Enter the stop bits	1 or 2 (Note 1)
R	Enter the parity mode	N = None O = Odd E = Even
M	Enter the communication mode	A = ASCII R = RTU
Y	Enter the port priority	1 ... 4
L	Enter the link timeout value	1 ... 3000, in multiples of 100 ms
F	Enter the modem booster selection	Y = Yes N = No
W	Write the configuration parameters to all four ports	
D	Initialize all four ports with default parameters	
?	Display Help for the current configuration screen	
E	<p>Enter a Modbus address and five-byte routing path into the Modbus Address Map table on the V2 or V3 screen.</p> <p>When you use this command, enter the following:</p> <ul style="list-style-type: none"> <li>– the E command</li> <li>– the table location (1 ... 64) for your entry</li> <li>– the Modbus address (1 ... 255) to be mapped</li> <li>– the five bytes of routing (1 ... 255 in each byte).</li> </ul>	<p>Entry format: EYY MM XX XX XX XX XX</p> <p>where:</p> <p>E = Modbus Address Map command YY = location (1 ... 64) in the table MM = Modbus address (1 ... 255) XX = each byte (1 ... 255) in the path.</p>

### Notes

1. Models NW-BM85C002 and NW-BM85D008 do not have a Stop Bits setting. These models default to 8 data bits with 1 Stop Bit.

### 3.6.1 The Default Configuration

When you enter the command **D** the entire set of parameters and Modbus Address Map tables for the ports will be set to their default configuration. All four ports will be simultaneously set to their defaults.

Parameter	Port 1	Port 2	Port 3	Port 4
Port type	Master	Slave	Slave	Slave
Slave device address	—	1	1	1
Baud rate	9600	9600	9600	9600
Stop bits	1	1	1	1
Parity mode	Even	Even	Even	Even
Communication mode	RTU	RTU	RTU	RTU
Port priority	1	2	3	4
Link timeout value	—	600	600	600
Modem booster	—	—	—	—

The Modbus Address Map tables for all four ports will be set to zeros.

## 3.7 Your Configuration Screens

---

You have four configuration screens:

### **V1**

Use this screen to display and set the communication parameters for each port.

### **V2**

Use this screen to display and set locations 1 ... 32 of the Modbus Address Map table for each port.

### **V3**

Use this screen to display and set locations 33 ... 64 of the Modbus Address Map table for each port.

### **V4**

Use this screen to Save or Initialize the BM85 configuration.

### **Help Screens: V5, V6, V7, V8**

You have four Help screens that you can access during configuration. You can select the Help screens by selecting screens V5, V6, V7, or V8. Pressing the 'question mark' ( ? ) key will display Help for the configuration screen you are currently using.

### 3.7.1 Entering Commands Into Your Screens

When the BM85 is initially powered up for configuration, the V1 screen is shown for port 1. You can begin entering the port 1 parameters immediately.

The currently active port is always shown at the bottom line of your screen.

To select another screen for the active port, enter commands V1, V2, V3, or V4. To select another port, enter commands P1, P2, P3, or P4.

When you enter the configuration commands, you can enter them singly or as a string. Press ENTER to complete the entry. To correct keystrokes in an entry, press DELETE. To cancel an entry before completing it, press ESCAPE.

### **3.7.2 Printing the Configuration**

If you have a printer connected to your terminal, you can use your 'Print Screen' (or equivalent) key to print a hard copy record of your V1, V2, and V3 screens.

### **3.7.3 Saving the Configuration**

After configuring the Modbus ports, save your configuration using the V4 screen.

## 3.8 Your V1 Screen

### 3.8.1 Your V1 Screen Layout

Figure 11 shows a typical V1 screen. Valid commands are listed on the screen.

```
MODICON MODBUS BRIDGE/MUX – Ver. 1.0
Copyright (c) 1989 MODICON, Inc., Industrial Automation Systems Group
MODBUS PORTS CONFIGURATION [V1]
Modbus Plus Address = 24

<COMMANDS>                                     [OPTIONS]

<P>PORT NUMBER#          1           2           3           4           [1, 2, 3, 4]
<T>PORT TYPE            master        slave        network      slave        [m, s, n, x]
<N>Slave Dev Addr       –           1           –           230         [1–247]
<B>Baud Rate            9600       1200       2400       9600        [50–19200]
<S>Stop Bits           1           2           1           1           [1, 2]
<R>Parity               even        none        even        even        [n, o, e]
<M>Mode                 rtu        ascii       rtu         rtu         [a, r]
<Y>Priority              1           2           3           4           [1–4]
<L>Link Timeout        –           20          10          600        [1–3000]
<F>Modem Booster       –           yes         yes         no         [y, n]

>>Valid Commands:[V1 V2 V3 V4 P T N B S R M Y L F]   Keys:[Enter Esc ?–help]

Active Port 1>> _
```

Figure 11 Typical V1 Screen: Modbus Ports Configuration



### 3.8.2 Using the V1 Screen

Select the port you want to configure. For example, enter P4 to select Port 4 and make it the active port.

Your currently selected port is shown on the bottom line of the screen.

Specify the port type by entering T with one of the following types: M (Master), S (Slave), N (Network), or X (Silent Master). For example, enter TS to setup the currently active port as a slave port. A Silent Master port will be labeled 'xmaster' on the screen.

Specify the port communication parameters you want to use. For example, enter B9600 to set the port for 9600 baud.

You can also enter the complete command sequence as a string, separated by spaces.

#### Example

To configure Port 4 as a Slave port, Device Address 230, 9600 baud, 1 Stop Bit, Even Parity, RTU, Port Priority 4, 60 seconds Link Timeout, and No Modem Booster, you would enter the following command string:

```
P4 TS N230 B9600 S1 RE MR Y4 L600 FN <ENTER>
```

## 3.9 Your V2 and V3 Screens

### 3.9.1 Your V2 or V3 Screen Layout

The V2 screen sets up Modbus Address Map table entries 1 ... 32 for the currently selected port. The V3 screen sets up the table entries 33 ... 64. Except for their table entries, the two screens are identical.

Figure 12 shows a typical V2 screen. Valid commands are listed on the screen.

```
MODBUS ADDRESS MAP FOR [E1-E32] [V2]
MAPS: Modbus Address to Destination Address [Port Type: Master]

Table Entry  Modbus Address  Destination Address (5 bytes)  Table Entry  Modbus Address  Destination Address (5 bytes)
<E1 > [020]= 021 022 023 024 025  <E17> [000]= 000 000 000 000 000
<E2 > [000]= 000 000 000 000 000  <E18> [000]= 000 000 000 000 000
<E3 > [000]= 000 000 000 000 000  <E19> [000]= 000 000 000 000 000
<E4 > [124]= 020 004 000 000 000  <E20> [000]= 000 000 000 000 000
<E5 > [000]= 000 000 000 000 000  <E21> [000]= 000 000 000 000 000
<E6 > [126]= 020 006 000 000 000  <E22> [000]= 000 000 000 000 000
<E7 > [000]= 000 000 000 000 000  <E23> [000]= 000 000 000 000 000
<E8 > [000]= 000 000 000 000 000  <E24> [000]= 000 000 000 000 000
<E9 > [000]= 000 000 000 000 000  <E25> [000]= 000 000 000 000 000
<E10> [000]= 000 000 000 000 000  <E26> [000]= 000 000 000 000 000
<E11> [000]= 000 000 000 000 000  <E26> [000]= 000 000 000 000 000
<E12> [000]= 000 000 000 000 000  <E28> [000]= 000 000 000 000 000
<E13> [000]= 000 000 000 000 000  <E29> [000]= 000 000 000 000 000
<E14> [000]= 000 000 000 000 000  <E30> [000]= 000 000 000 000 000
<E15> [000]= 000 000 000 000 000  <E31> [000]= 000 000 000 000 000
<E16> [000]= 000 000 000 000 000  <E32> [000]= 000 000 000 000 000

>>Valid Commands:[V1 V2 V3 V4 P E]  Keys:[Enter Esc ?-help]

Active Port 1>> _
```

Figure 12 Typical V2 Screen: Modbus Address Map Entries

## 310074923.9.2 Using the V2 or V3 Screen

Use the V2 screen for configuring entries 1 ... 32 for the selected port.  
Use the V3 screen for configuring entries 33 ... 64 for this port.

You can alternate between the V2 and V3 screens using commands V2 and V3.

The Table Entry column is a listing of locations in the table. Note that these are table entry locations, not Modbus addresses. You must enter the Modbus addresses that you want to map into the second column.

When you edit the table entries, you do not have to do so in a defined sequence. For example, you do not have to configure E1 before configuring another entry.

You do not have to fill all the table entries in the V2 screen before making an entry in the V3 screen. If you will use no more than 32 entries, you might find it convenient to keep them all on one screen.

### Example

To use the V2 screen table entry E1 to map Modbus address 20 to the routing path 21 22 23 24 25, you would enter the following string:

```
E1 20 21 22 23 24 25 <ENTER>
```

You may find it convenient to use a Modbus addressing convention that helps you to remember how addresses are mapped in your application. For example, you can use the Modbus address 124 to define mapping to a Modbus Plus node address 4, with routing through a Bridge Plus at address 20. In the same convention, Modbus address 126 would map to Modbus Plus node 6 through the same bridge. Examples are shown in table entries E4 and E6.

To map the addresses shown at E4 and E6, you would enter the following strings:

```
E4 124 20 4 0 0 0 <ENTER>
```

```
E6 126 20 6 0 0 0 <ENTER>
```

## 3.10 Your V4 Screen

---

### 3.10.1 Your V4 Screen Layout

Figure 13 shows a typical V4 screen. Valid commands are listed on the screen.

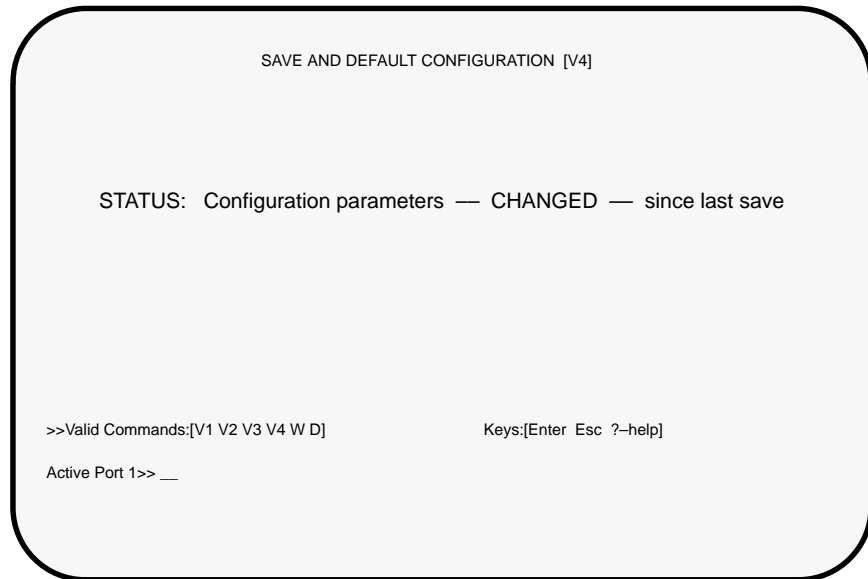

**Figure 13** Typical V4 Screen: Save or Initialize the Configuration

### 3.10.2 Using the V4 Screen

To write (save) the configuration you have entered into the BM85, enter the following command:

W <ENTER>

To initialize the entire set of configuration parameters in the BM85 to their default values, enter the following command:

D <ENTER>

Note that initializing the configuration parameters also clears the Modbus Address Map tables for all four ports to zeros.

### 3.11 Setting the Modbus Plus Address

Before applying power to the BM85, set its rear panel switches to the unit's Modbus Plus node address. Figure 14 shows the switch locations, combinations, and addresses. Set the address into switches 1 ... 6. Switches 7 and 8 are not used.

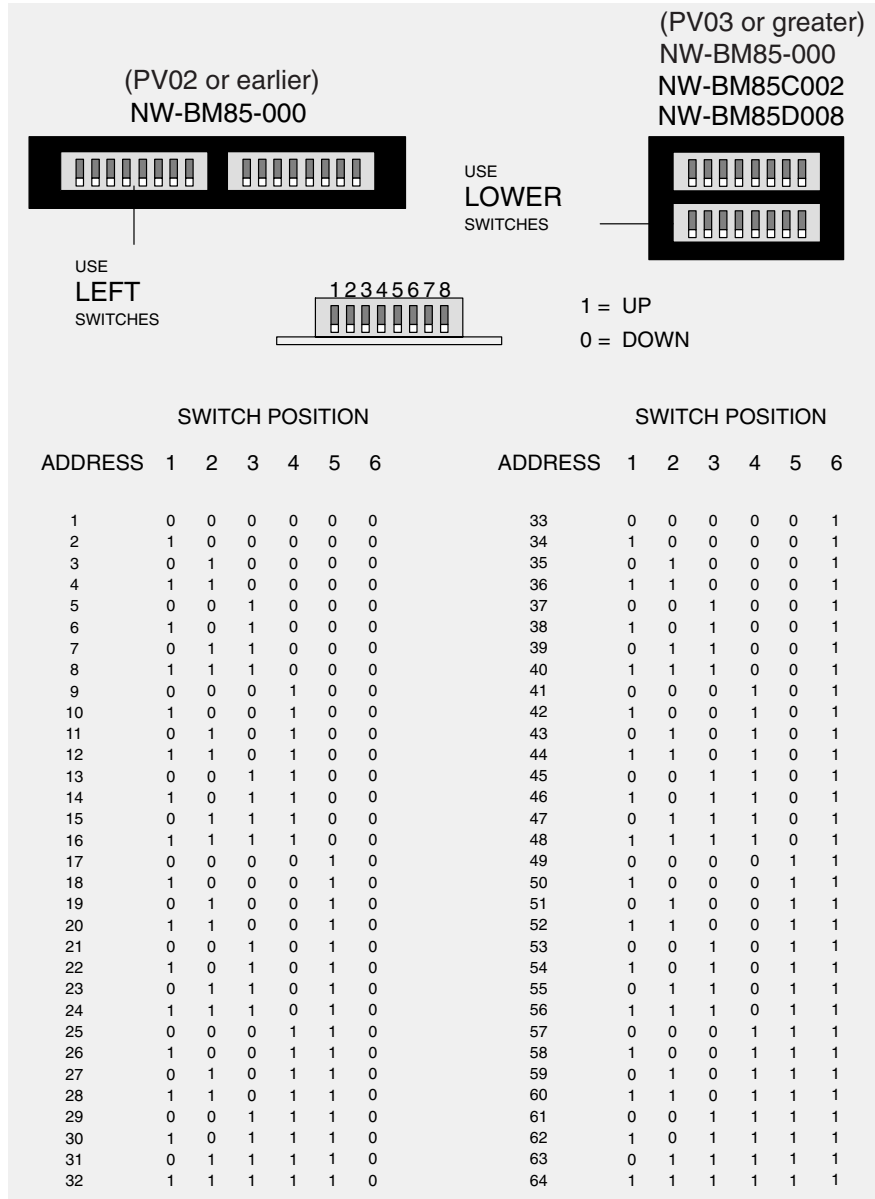

Figure 14 BM85 Modbus Models: Modbus Plus Address Switches

## 3.12 Setting the RUN Mode

---

### 3.12.1 When to Set the RUN Mode

Setting the BM85 to its RUN mode applies the parameters you have assigned, making the unit ready for operation on the Modbus Plus network and at its Modbus ports.

When the BM85 is in its RUN mode, it will become active in your application as soon as power is applied to the unit.



**Caution: You must complete the internal configuration of the BM85 before making the unit active in your application, both on the Modbus Plus network and at its serial ports.**

**If you are installing a BM85 that was previously configured for another application, another network, or a different node, the unit will still be retaining its previous configuration setup. You must not connect the unit into the current application and apply operating power to the unit until you have reconfigured it for the current application.**

### 3.12.2 How to Set the RUN Mode

Before you set the unit to RUN mode, verify that you have setup its Modbus port parameters and Modbus Plus node address as described in this chapter.

Turn off power to the Bridge Multiplexer and set its configuration switch 1 to the RUN position. Refer to Figure 10 for the configuration switch location and setting.

If you have set the BM85 configuration correctly for a specific installation site, you can transport the unit to the site and install it.

The RUN mode will be set when power is reapplied to the BM85.

## 3.13 Modbus Port Indicator Codes

---

If the BM85 detects a condition that prevents communication at its Modbus Plus or Modbus ports, it shuts off all ports and displays an error code pattern at its four Modbus port indicators.

Indicator layouts are shown in Figure 22.

The error pattern produces two 4-bit codes for two hexadecimal digits. First, the indicators show a steady pattern for one second, indicating the upper digit. Then they show a flashing pattern for one second with the lower digit. The continuous and flashing patterns alternate repetitively. Port 4 is the most significant bit in each code.

Indicators	Pattern	Hexadecimal Digit
4 – 3 – 2 – 1	Steady	Upper digit
4 – 3 – 2 – 1	Flashing	Lower digit

### Hardware Error Codes: 11 ... 19 Hex

Code (Hexadecimal)	Meaning
11	PROM checksum error
12	RAM data test error
13	RAM address test error
14	Normal power down event
17	Bad or unexpected interrupt
18	EEPROM checksum error
19	Modbus port loopback error

### Modbus Driver Error Codes: 24 ... 2E Hex

Code (Hexadecimal)	Meaning
24	Modbus transmit state error
25	Modbus receive state error
26	ASCII transmit communications state error
27	Transmit underflow error
28	RTU transmit communications state error
29	ASCII receive communications state error
2A	RTU receive communications state error
2B	Transmit communications state error
2C	Receive communications state error



2D	Modbus state timer event error
2E	UART interrupt error

### Modbus Plus Processor Interface Error Codes: 34 ... 36 Hex

Code (Hexadecimal)	Meaning
34	Modbus Plus Processor interface error
35	Modbus Plus Processor opcode response error
36	Timeout error waiting for Modbus Plus Processor

### LLC Layer Error Codes: 81 ... A3 Hex

Code (Hexadecimal)	Meaning
81	Master state error
82	Slave state error
83	Unknown routing failure to send
84 ... 8B	Port number error
91	Privilege flag not reset
92	Port number error
A2, A3	Unknown function code



# Chapter 4

## Configuring the Programmable Models

---

- Before You Start
- Required Equipment
- Overview of the Development Software
- Installing the Development Software
- Preparing the BM85 for Downloading
- Setting the Configuration Switches
- Setting the Modbus Plus Address
- Indicator Codes During Downloading
- Setting the RUN Mode

## 4.1 Before You Start

### 4.1.1 Models Covered in This Chapter

This chapter covers the configuration process for the following models:

Part Number	Mounting Method	Operating Power (Nominal)	Modbus Plus Network Cable	Serial Ports	Serial Protocol
NW-BM85E232	Panel or Shelf	115/230 Vac or 24 Vdc	Single or Dual	RS232	Programmable, User Defined
NW-BM85D002	19 in Rack	125 Vdc or 24 Vdc	Single or Dual	RS232	Programmable, User Defined
NW-BM85E485	Panel or Shelf	115/230 Vac or 24 Vdc	Single or Dual	RS485	Programmable, User Defined
NW-BM85S232	Panel or Shelf	115/230 Vac or 24 Vdc	Single or Dual	RS232	Programmable, User Defined
NW-BM85S485	Panel or Shelf	115/230 Vac or 24 Vdc	Single or Dual	RS485	Programmable, User Defined

### 4.1.2 An Overview of the Configuration Process

The BM85 requires an internal program for controlling its operation, with parameters for each serial port you will use in your application. The unit contains a non-volatile memory that stores your program and port configurations, even when operating power is removed.

You must create your BM85 application program and download it across the Modbus Plus network to the BM85. A switch is provided on the BM85 to enable the unit to accept the download. If the unit is already installed at its site and connected to the network, you can download your program to it. You can also download your program at a spare network connection near your download host, then transport the configured BM85 to the site and install it.



**Caution:** You must complete the internal configuration of the BM85 before making the unit active in your application, both on the Modbus Plus network and at its serial ports.

**If you are installing a BM85 that was previously configured for another application, another network, or different node, the unit will still be retaining its previous configuration setup. You must not connect the unit into the current application and apply operating power to the unit until you have reconfigured it for the current application.**

## 4.2 Required Equipment

---

### 4.2.1 Equipment for Writing the Application Program

First, you must create your BM85 application program. For this you will need the BM85 Program Development Software Tool Kit. Part numbers and ordering information are provided in the *BM85 Specifications*, Section 1.7.2.

For compatibility with the BM85 development software, your PC hardware should be an MS-DOS compatible platform with at least 4 Megabytes of RAM.

You will also need the Borland C/C++ compiler at version 3.1 or later, which should already be installed in your development computer. The BM85 applications use the Large model. You should ensure that the Borland Large model libraries are installed.

### 4.2.2 Equipment For Downloading the Application Program

After you create the BM85 application, you must download it to the BM85 across Modbus Plus. Your hardware should be an IBM AT compatible or Micro Channel PC (486 or higher recommended), with at least 4 Megabytes of RAM. The required equipment is described in the *BM85 Specifications*, Section 1.7.3.

Your download host can be the same PC you used for the application development, with the addition of a Modicon SA85 or SM85 Network Adapter. The host could also be a separate PC node on Modbus Plus, in which you have stored only the application and downloader software.

You might find it more convenient for developing and debugging your application if you use the same PC for downloading. Downloading can be performed from within the Borland development environment.

The SA85 connects an ISA (AT) bus host to Modbus Plus. The SM85 connects a Microchannel bus host. Each adapter includes a device driver program that you will install during your installation of the adapter into your host computer.

Your BM85 development software includes a download utility that you can run with either the SA85 or SM85.

## 4.3 Overview of the Development Software

---

This overview of the BM85 Program Development Software Tool Kit is provided to assist your planning. Examples are shown for the Borland 3.1 environment. Complete documentation is supplied with the kit. Part numbers and ordering information are in the *BM85 Specifications*, Section 1.7.2.

Your BM85 software includes all of the development files for compiling and downloading your application. You also have an assortment of source code files that you can use as examples.

### 4.3.1 Development Software Files

The following BM85 development files are supplied:

File Name	Purpose
README.DOC	Complete BM85 development information text file. View or print this file for current information about your software.
BM85LOAD.EXE	The BM85 download utility
MBPSTIM.EXE	Data transfer exerciser. Reads registers and writes a single register to a controller over Modbus Plus.
BM85.EXE	User-compiled demonstration program to be downloaded. See the descriptions of the test programs below.
BM85.PRJ	Borland C++ 3.1 project file to build BM85.EXE
BM85.H	Header file containing function prototypes of utility routines
C0BM85.OBJ	BM85 startup code
BM85.C	Source file for user base demonstration program. Copy the source for a specific test program into this file and compile it. Initially supplied as TEST0.C. See the test programs below.
BM85LIB.LIB	Library of utility routines
MBPHOST.SYS	Device driver for Modbus Plus network adapter
MBPSTAT.EXE	Modbus Plus network management and diagnostic utility
BDRESET.EXE	Initializes and enables the Modbus Plus adapter

### 4.3.2 The README.DOC Information File

Your disks contain an information text file README.DOC. This file contains detailed information about developing, compiling, and downloading your BM85 application using the Borland environment. It also contains any recently updated information about your BM85 software. Before installing the software, you should view this file. You may also want to printout a hard copy to use as a reference in developing your application..

### 4.3.3 Test and Demonstration Source Files

The following files provide source code examples that you can use in your development. They can also be modified and used as test programs for exercising and testing your BM85.

File Name	Purpose
TEST0.C	Displays a code on the BM85 LED indicators
TEST1.C	Shows Modbus Plus master and slave operation
TEST2.C	Demonstrates multitasking using the BM85 indicators
TEST3.C	Demonstrates floating point emulator
TEST4.C	Simulates process control with multitasking, C++ conventions
TEST5.C	Same as TEST4.C, but uses C conventions
TEST6.C	RS232 port loopback test
TEST7.C	RS232/RS485 port loopback test, long term
TEST8.C	Sample large program (240K) for download testing

#### Using the Test and Demonstration Source Files

To use any file, first copy it to the filename BM85.C, then modify that file for your BM85 application and compile it. Download the executable BM85.EXE to the BM85 using the BM85LOAD utility. For example, the download can be run within the Borland 3.1 environment using the following sequence:

Key Sequence	Purpose
Alt-space	Transfer menu
m	BM85 download

### 4.3.4 Multitasking in Your Application

The BM85 library includes functions that you can use to construct a routine for assigning and controlling multiple tasks or threads within your application. Multitasking is handled on a cooperative basis: an active task routine must make periodic calls to an arbitration routine, allowing that routine to either continue the calling task or handle another pending task.

Your demonstration programs TEST4.C and TEST5.C provide source examples of the use of the library's multitasking functions. TEST4.C is coded in C++. TEST5.C is coded in C for programmers who are more familiar with that language.

## 4.4 Installing the Development Software

---

This overview of the software installation process is supplied to assist your planning. Complete documentation is provided in the software kit.

Substitute the paths and parameters used in your Borland development environment wherever applicable.

### 4.4.1 Default Parameters

The development software is supplied with two default parameters for downloading to your BM85. One parameter specifies how to access your SA85/SM85 driver (the default specifies software interrupt vector 5C). The other parameter is the Modbus Plus node address of the target BM85 unit for downloading (the default is node address 4).

If your SA85/SM85 driver and BM85 are set to these parameters, your installation will be easier because you can bypass part of the setup (see Steps 6 and 7 below).

### 4.4.2 Installation Steps

1. If you have already installed the SA85/SM85 Modbus Plus adapter and its driver, and have edited your CONFIG.SYS file to include a DEVICE command with driver parameters, you can skip this step.

If you have not installed your adapter and driver, then you should do so now, before proceeding with the BM85 software installation. Follow the instructions in the guidebook supplied with your adapter.

Part of the adapter installation procedure requires you to specify a software interrupt vector, or to accept the default vector 5C. If you specify a vector other than the default, make a note of the vector. You will need this information when you install the BM85 software.

2. Ensure that your Borland C/C++ software is installed on your computer and is specified in your PATH command. For example, if the compiler's executable files are in C:\BORLANDC\BIN then your PATH command should specify this path.
3. Create a working directory for your BM85 development files, and copy the entire contents of your BM85 development disk into this directory. A suggested name for the new directory is: C:\MBCP.



4. Start your Borland compiler development environment as described in your compiler documentation.
5. Update the BM85 Project file BM85.PRJ to set the correct directory paths for your Borland environment. For example, in the Borland 3.1 environment, you can use the following key sequence:

Key Sequence	Purpose
Alt-P	Project open
BM85.PRJ	Project name
Alt-O D	Option directories
(paths)	Update the paths for your INCLUDE and LIBRARY directories

6. If either of these parameters is true, continue with Step 7. If neither is true, skip Step 7 and go to Step 8.
  - Your SA85/SM85 interrupt is set to a vector other than 5C
  - Your BM85 Modbus Plus node address is other than 4.
7. Update the BM85LOAD and MBPSTIM command lines in the BM85 project's TRANSFER menu to use the new parameters. In the Borland 3.1 environment, you can use the following key sequence:

Key Sequence	Purpose
Alt-T	Transfer menu
Select command line	Select the BM85 DOWNLOAD or MBPLUS STIMULATE line
Alt-E	Edit
Alt-C	Command line
Enter parameters	Set the parameters as they are used in your application
Alt-M	Modify
Alt-K	OK

8. When you have updated your project file, close the project. In the Borland 3.1 environment, you can use the following key sequence:

Key Sequence	Purpose
Alt-C	Project close

## 4.5 Preparing the BM85 for Downloading

---

The BM85 rear panel has two sets of switches. One set allows the BM85 to either accept a download or run an application that was previously downloaded. The other set of switches assigns a Modbus Plus node address.

Before you can download your application you must set the switches to allow the load. You must also set the node address to agree with the address parameter you are using with the download utility program. Instructions for setting the switches are provided in Sections 4.6 and 4.7.

You can download to the BM85 at its installation site. You might find it more convenient to have a spare Modbus Plus network connector in the vicinity of your download host, and to perform the download locally.



**Caution:** Adding a new node to an active network causes an increase in the network's token rotation time, reducing the overall data throughput. Before you connect or disconnect any device on an active network, you should be aware of its effect on network timing.

After the download is completed, the BM85 switches must be set to allow it to run the application. All BM85 switch settings are sensed on power-up.

## 4.6 Setting the Configuration Switches

Before applying power to the BM85, set its rear panel switches to allow either downloading or running your application. Figure 15 shows the switch locations and setup.

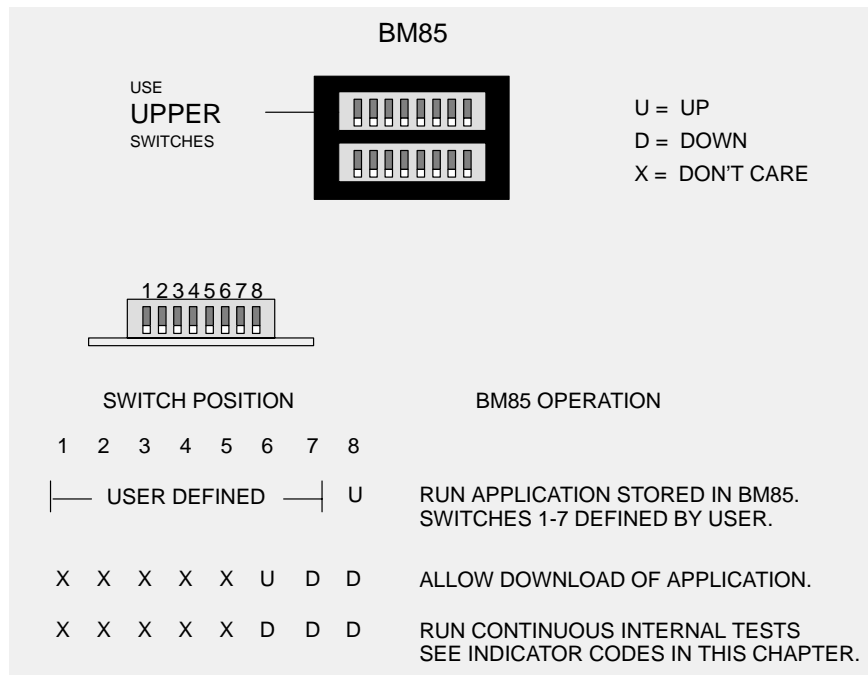

**Figure 15** BM85 Programmable Models: Configuration Switches

## 4.7 Setting the Modbus Plus Address

Before applying power to the BM85, set its rear panel switches to the unit's Modbus Plus node address. Figure 16 shows the switch locations, combinations and addresses. Set the address into switches 1 ... 6. Switches 7 and 8 are not used.

**BM85**

USE  
**LOWER**  
SWITCHES

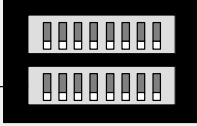

1 = UP  
0 = DOWN

SWITCH POSITION							SWITCH POSITION						
ADDRESS	1	2	3	4	5	6	ADDRESS	1	2	3	4	5	6
1	0	0	0	0	0	0	33	0	0	0	0	0	1
2	1	0	0	0	0	0	34	1	0	0	0	0	1
3	0	1	0	0	0	0	35	0	1	0	0	0	1
4	1	1	0	0	0	0	36	1	1	0	0	0	1
5	0	0	1	0	0	0	37	0	0	1	0	0	1
6	1	0	1	0	0	0	38	1	0	1	0	0	1
7	0	1	1	0	0	0	39	0	1	1	0	0	1
8	1	1	1	0	0	0	40	1	1	1	0	0	1
9	0	0	0	1	0	0	41	0	0	0	1	0	1
10	1	0	0	1	0	0	42	1	0	0	1	0	1
11	0	1	0	1	0	0	43	0	1	0	1	0	1
12	1	1	0	1	0	0	44	1	1	0	1	0	1
13	0	0	1	1	0	0	45	0	0	1	1	0	1
14	1	0	1	1	0	0	46	1	0	1	1	0	1
15	0	1	1	1	0	0	47	0	1	1	1	0	1
16	1	1	1	1	0	0	48	1	1	1	1	0	1
17	0	0	0	0	1	0	49	0	0	0	0	1	1
18	1	0	0	0	1	0	50	1	0	0	0	1	1
19	0	1	0	0	1	0	51	0	1	0	0	1	1
20	1	1	0	0	1	0	52	1	1	0	0	1	1
21	0	0	1	0	1	0	53	0	0	1	0	1	1
22	1	0	1	0	1	0	54	1	0	1	0	1	1
23	0	1	1	0	1	0	55	0	1	1	0	1	1
24	1	1	1	0	1	0	56	1	1	1	0	1	1
25	0	0	0	1	1	0	57	0	0	0	1	1	1
26	1	0	0	1	1	0	58	1	0	0	1	1	1
27	0	1	0	1	1	0	59	0	1	0	1	1	1
28	1	1	0	1	1	0	60	1	1	0	1	1	1
29	0	0	1	1	1	0	61	0	0	1	1	1	1
30	1	0	1	1	1	0	62	1	0	1	1	1	1
31	0	1	1	1	1	0	63	0	1	1	1	1	1
32	1	1	1	1	1	0	64	1	1	1	1	1	1

Figure 16 BM85 Programmable Models: Modbus Plus Address Switches

## 4.8 Indicator Codes During Downloading

During downloading or internal testing, the four serial ports are disabled and their indicators are used to show system status and error codes.

Indicator layouts are shown in Figure 22.

### 4.8.1 Normal Download Codes

The normal codes appearing during downloading are:

Indication	Meaning
Port 4 — Flashing two times per second	Ready for downloading
Port 3 — ON intermittently	Receiving download from host
Port 2 — ON (combined with port 3)	Writing to BM85 RAM
Port 1 — ON (combined with port 3)	Erasing BM85 RAM

### 4.8.2 Error Codes

If an error occurs during downloading, or if the user calls the `exit()` routine, the BM85 displays an error pattern in its four indicators.

The error pattern produces two 4-bit codes for two hexadecimal digits. First, the indicators show a steady pattern for one second, indicating the upper digit. Then they show a flashing pattern for one second with the lower digit. The continuous and flashing patterns alternate repetitively. Port 4 is the most significant bit in each code.

Indicators	Pattern	Hexadecimal Digit
4 – 3 – 2 – 1	Steady	Upper digit
4 – 3 – 2 – 1	Flashing	Lower digit

Error Code (Hexadecimal)	Meaning
F1	BM85 kernel is reloading
F4	Program or task returned to BM85 bootstrap
F8	Program or task called abort()
FD	Could not extend heap – program called <code>malloc()</code> or equivalent and had insufficient memory
FE	Could not create heap – not enough memory below code area
FF	Not enough memory to copy program to RAM area

## 4.9 Setting the RUN Mode

---

### 4.9.1 When to Set the RUN Mode

Setting the BM85 to its RUN mode applies the parameters you have assigned, making the unit ready for operation on the Modbus Plus network and at its Modbus ports.

When the BM85 is in its RUN mode, it will become active in your application as soon as power is applied to the unit.



**Caution:** You must complete the internal configuration of the BM85 before making the unit active in your application, both on the Modbus Plus network and at its serial ports.

**If you are installing a BM85 that was previously configured for another application, another network, or a different node, the unit will still be retaining its previous configuration setup. You must not connect the unit into the current application and apply operating power to the unit until you have reconfigured it for the current application.**

### 4.9.2 How to Set the RUN Mode

Before you set the unit to RUN mode, verify that you have setup its Modbus port parameters and Modbus Plus node address as described in this chapter.

Turn off power to the Bridge Multiplexer and set its configuration switch 8 to the RUN position. Refer to Figure 15 for the configuration switch location and setting.

If you have set the BM85 configuration correctly for a specific installation site, you can transport the unit to the site and install it.

The RUN mode will be set when power is reapplied to the BM85.

# Chapter 5

## Installing the BM85

---

- Installing the BM85 Hardware
- Connecting the Power Cables
- Connecting the Network Cables
- Reading the Indicators
- Modbus Port Error Codes
- Attaching Identification Labels

# 5.1 Installing the BM85 Hardware

## 5.1.1 Mounting the BM85

BM85 models are available for mounting on a horizontal shelf or vertical panel, or for installation into a standard 19 inch rack. Install your unit using the guidelines in Section 5.1.2 (for shelf or panel mounting) or 5.1.3 (for rack mounting).

The BM85 has a set of LED indicators to show its operating status. Your choice of a mounting method should include proper access for observing these indicators.

You should also provide access to the unit's rear panel for setting the switches, connecting the cables, and servicing.



**Caution: Do not connect the BM85 into your application environment unless you have set its internal configuration. Do not connect it to your network or to any device unless you have set its switches properly for configuring or running.**

See the *Specifications* Sections 1.6 and 1.7 for details about the BM85 operating power, environment, and connector requirements.

## 5.1.2 Shelf/Panel Mounted Models

Part Number	Mounting Method	Operating Power (Nominal)	Modbus Plus Network Cable	Serial Ports	Serial Protocol
NW-BM85-000	Panel or Shelf	115/230 Vac	Single	Modbus	ASCII or RTU
NW-BM85C002	Panel or Shelf	115/230 Vac or 24 Vdc	Single or Dual	Modbus	ASCII or RTU
NW-BM85E232	Panel or Shelf	115/230 Vac or 24 Vdc	Single or Dual	RS232	Programmable, User Defined
NW-BM85E485	Panel or Shelf	115/230 Vac or 24 Vdc	Single or Dual	RS485	Programmable, User Defined
NW-BM85S232	Panel or Shelf	115/230 Vac or 24 Vdc	Single or Dual	RS232	Programmable, User Defined
NW-BM85S485	Panel or Shelf	115/230 Vac or 24 Vdc	Single or Dual	RS485	Programmable, User Defined

Mounting dimensions of these models are shown in Figure 17.



### Horizontal Mounting

The bottom surface of these models is fitted with pads for mounting on a horizontal platform or shelf. Place the unit at or below eye level to allow viewing the indicators. Mounting brackets are supplied with the unit for securing it on the horizontal surface.

### Vertical Mounting

For vertical mounting, use the brackets supplied with the unit for bolting to a panel. The brackets have tabs that insert into slots provided on the unit's bottom surface. No additional hardware is required for securing the brackets to the BM85. You will have to furnish hardware for bolting the unit to your panel. Four bolts are required. Typically, standard 1/4-20 (10 mm) machine screws or equivalent are satisfactory. Install the unit at or below eye level to allow viewing the indicators.

## 5.1.3 Rack Mounted Models

Part Number	Mounting Method	Operating Power (Nominal)	Modbus Plus Network Cable	Serial Ports	Serial Protocol
NW-BM85D008	19 in Rack	125 Vdc or 24 Vdc	Single or Dual	Modbus	ASCII or RTU
NW-BM85D002	19 in Rack	125 Vdc or 24 Vdc	Single or Dual	RS232	Programmable, User Defined

Mounting dimensions of these models are shown in Figure 18.

Rack-mount models are designed for installation into a standard 19-inch rack. You will have to furnish hardware for bolting the unit to your rack. Four bolts are required.

When mounted, the unit can support itself by its front mounting bolts. It is light enough in weight that you do not have to provide rear support within the rack.

## TOP VIEW

Allow 4.0 in (102 mm) rear clearance  
for access to switches, cables, and fuse

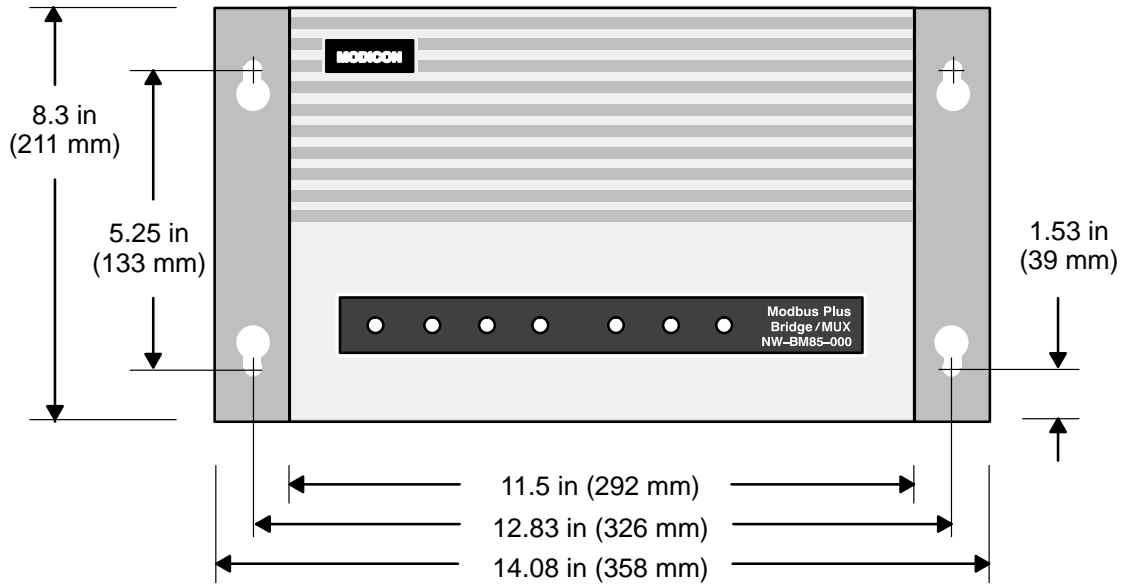

## REAR PANEL VIEW

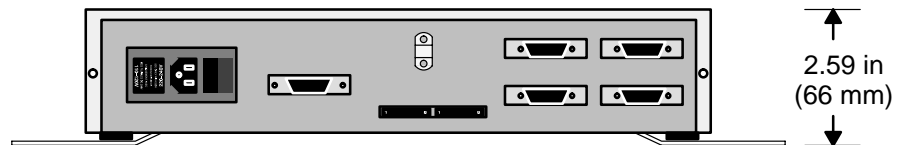
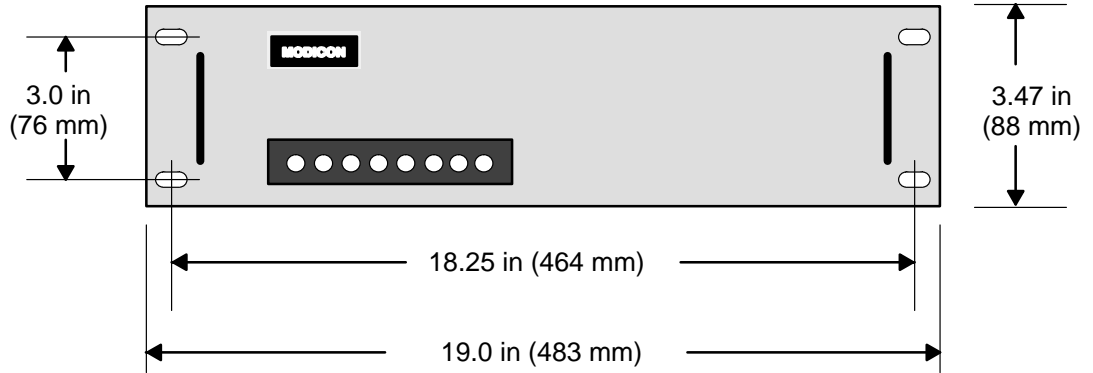

Figure 17 Mounting Dimensions: Shelf/Panel Mount Models

# FRONT PANEL VIEW



## 31007492OP VIEW

Allow 4.0 in (102 mm) rear clearance for access to switches and cables

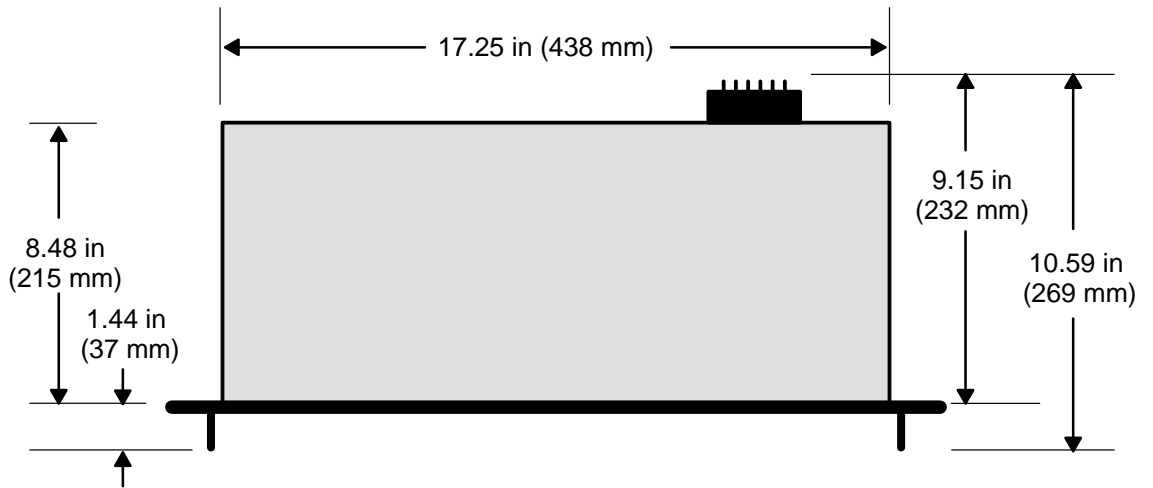

Figure 18 Mounting Dimensions: Rack Mount Models

## 5.2 Connecting the Power Cables

---

See Sections 1.6 and 1.7 *Specifications* for details about the BM85 operating power and connector requirements.



**Caution:** You can connect power cables to the BM85, but ensure that the power is OFF before connecting the network or serial cables to the unit.

### AC/DC Models

AC/DC models are supplied with a power cable of 6 ft (2 m) length for operation from 110-120 Vac or 220-240 Vac single-phase power. The cable connects to a socket on the rear panel. Grounding is through the cable. The ac line switch is located on the rear panel. The BM85 contains an ac line fuse that is accessible on the rear panel.

All of these models except the BM85-000 can also operate from an external 24 Vdc source. Power connects to a socket on the rear panel. Grounding is through the cable. The dc source must be switched and fused externally to the BM85.

### DC/DC Models

DC/DC models operate from a 125 Vdc or 24 Vdc source. Power connects to a terminal strip on the rear panel. A grounding terminal is provided. The dc source must be switched and fused externally to the BM85.

### 5.2.1 Connecting AC Power

Set the BM85 power switch to the '0' (power OFF) position. Connect the BM85 to the power source. Set the power switch to '1' (power ON). The unit's POWER indicator should illuminate.

Before connecting the network cables, set the power switch to the '0' (power OFF) position. The unit's POWER indicator should not be lit.

### 5.2.2 Connecting DC Power

Set the external dc power source to OFF. Connect the BM85 to the source. Set the dc power source to ON. The BM85 unit's POWER indicator should illuminate.

Before proceeding with the connection of the network cables, set the dc power source to OFF. The unit's POWER indicator should not be lit.

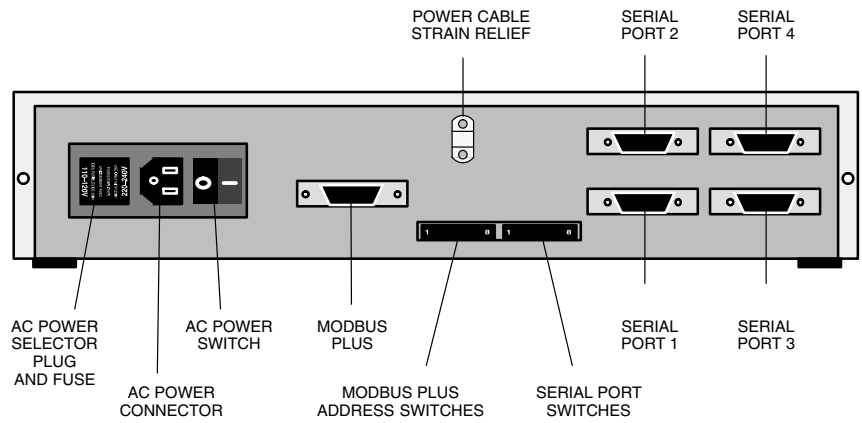

**Figure 19 BM85-000 Rear Panel (PV02 or earlier)**

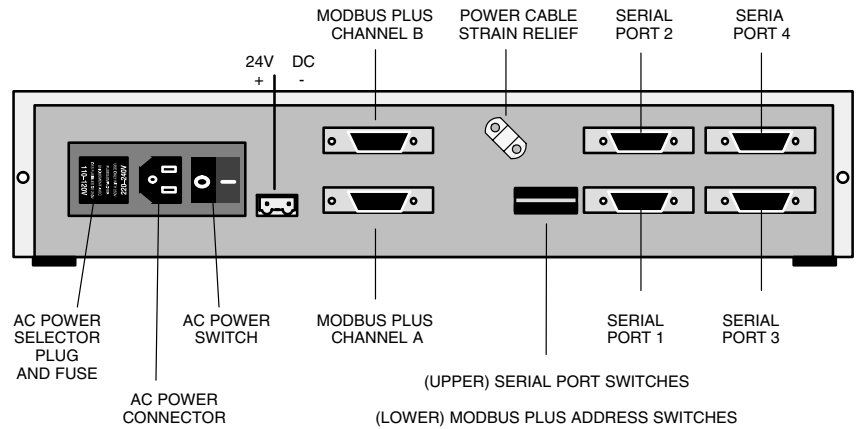

**Figure 20 BM85C, BM85E, BM85S Rear Panel, BM85-000 (PV03 or greater)**

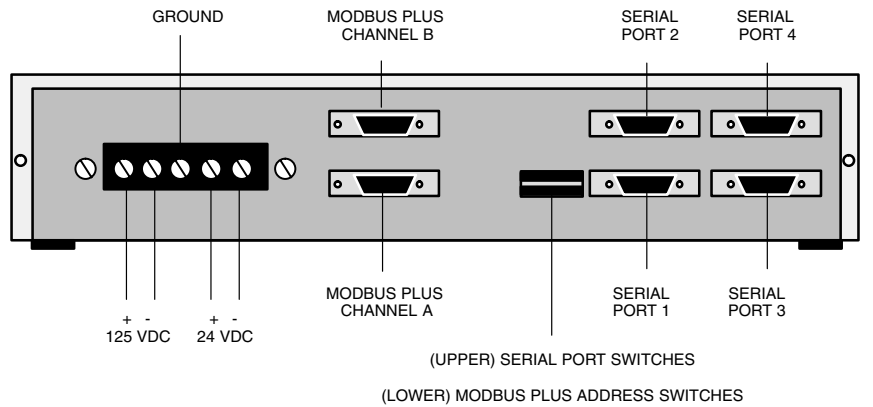

**Figure 21 BM85D Rear Panel**

## 5.3 Connecting the Network and Serial Cables

---

Network and serial cable connectors are located on the BM85 rear panel. Rear panel views are provided in the following figures:

- Figure 19: BM85-000
- Figure 20: BM85C, E, S
- Figure 21: BM85D

Read the Cautions below before connecting any cable to the BM85.

After connecting each cable, secure the connection by tightening its two screws.



**Caution:** If you are connecting the unit to the network for the purpose of communicating in your application, you must first ensure that you have set the unit's internal configuration for the specific site at which you are installing the unit. If you have not done this, you must first configure the unit as described in this guidebook.

If you are connecting the unit to the network for the purpose of downloading its configuration from your host computer, you must set the unit's rear panel switches for downloading . You must do this before connecting the network cables, and before applying operating power to the unit.



**Caution:** If the network is active, communication between the devices on the network will be affected as you connect the BM85 to the network. Before connecting any device on an active network, you should know the affect of connecting that device.



**Caution:** If the cables at the installation site are not labeled, or if you do not have a layout diagram showing how to connect the cables, obtain that information before proceeding.

### **5.3.1 Connecting a Single Network Cable**

On single-cable networks, connect the Modbus Plus cable to the BM85 Modbus Plus connector.

### **5.3.2 Connecting Dual Network Cables**

On dual-cable networks, connect Modbus Plus cables A and B to the correct connectors on the BM85 rear panel. Make sure to identify the correct cables and connectors.

### **5.3.3 Connecting Dual-Cable Units on Single-Cable Networks**

If you are installing a dual-cable unit on a network that has only a single cable, connect the cable to the rear panel CHANNEL A connector. Plug a Terminating Connector (Modicon part number AS-MBKT-185) into the CHANNEL B connector.

### **5.3.4 Connecting Serial Port Cables**

Connect the serial port device cables to the four connectors on the rear panel. Make sure to identify the correct device cables and connectors.

## 5.4 Reading the Indicators

The layout of the BM85 indicators is shown below.

BM85-000:	Modbus Port 4	Modbus Port 3	Modbus Port 2	Modbus Port 1		Modbus Plus Port	Power ON	Ready
BM85C:	power ok	Modbus Plus	error Chan A	error Chan B	Modbus port 1	Modbus port2	Modbus port 3	Modbus port 4
BM85E232, BM85S232:	power ok	Modbus Plus	error Chan A	error Chan B	RS232 port 1	RS232 port2	RS232 port 3	RS232 port 4
BM85E485, BM85S485:	power ok	Modbus Plus	error Chan A	error Chan B	RS485 port 1	RS485 port2	RS485 port 3	RS485 port 4
BM85D002:	RS232 port 4	RS232 port 3	RS232 port2	RS232 port 1	error Chan B	error Chan A	Modbus Plus	power ok
BM85D008:	Modbus port 4	Modbus port 3	Modbus port2	Modbus port 1	error Chan B	error Chan A	Modbus Plus	power ok

Figure 22 Layout of the Indicators

### 5.4.1 POWER and READY Indicators

The POWER indicator illuminates steadily when the BM85 has power from the source and its internal power supply is operating normally.

The READY indicator (BM85-000 only) illuminates steadily when the BM85 has successfully completed its internal diagnostics.

### 5.4.2 Modbus and Serial Port Indicators

On the Modbus port models, each Modbus port indicator flashes when a valid message is received at its port. If an internal fault exists, an error pattern is flashed. These codes are listed in Section 3.13.

On the programmable port models, each port indicator is programmable to show status that is specific to the application. Codes are flashed to show status during downloading. These codes are listed in Section 4.8.



### 5.4.3 Modbus Plus Port Status Indicators

The green MODBUS PLUS indicator shows the overall communication status at the BM85 node. Two red indicators for ERROR CHANNEL A and ERROR CHANNEL B identify errors on the two Modbus Plus cable paths.

If the ERROR CHANNEL A or ERROR CHANNEL B indicator blinks momentarily, it indicates that a message error was detected on the Modbus Plus cable path. A steady ON state indicates a hard fault exists, either in the cable or in a node device connected to it. If communication is lost on one cable path, the other path continues normally.

The MODBUS PLUS indicator flashes repetitive patterns to show the BM85 node's communication status on the Modbus Plus network. The patterns are:

#### **Six Flashes per Second**

This is the BM85 node's normal operating state. All nodes on the network should be flashing this pattern. If the indicator is OFF continuously, the BM85 is not transmitting on the network.

#### **One Flash per Second**

The BM85 node is offline after just being powered up, or after hearing a message from another node with the same network address (duplicate addresses are not allowed). In this state, the node monitors the network and builds a table of active nodes. It remains in this state for five seconds, then attempts to go to its normal operating state.

#### **Two Flashes, then OFF for Two Seconds**

The BM85 node is hearing the token being passed among other nodes, but is never receiving the token. Check the network link for an open or short circuit, or defective termination.

#### **Three Flashes, then OFF for 1.7 Seconds**

The BM85 node is not hearing any other nodes. It is claiming the token, but finding no other node to which to pass it. Check the network link for an open or short circuit, or defective termination.

#### **Four Flashes, then OFF for 1.4 Seconds**

The BM85 node has heard a valid message from another node that is using the same address as this node. The BM85 node remains offline in this state as long as it continues to hear the duplicate address. If the duplicate address is not heard for five seconds, the node then changes to the pattern of one flash every second.

## 5.5 Attaching Identification Labels

---

Labels are supplied with the BM85 for recording the unit's setup parameters. Use these labels to provide ready information for persons who will maintain the BM85 in the future.

Before completing the BM85 installation, enter the required information on the labels and attach them to the BM85. Place the labels on the unit in positions where they can be easily seen.

### 5.5.1 Modbus Plus Port Label

On this label enter the Modbus Plus network number and node address you have assigned to the BM85. Place the label on the BM85 so that it can readily identify the unit in your application.

Figure 23 shows the layout of the label.

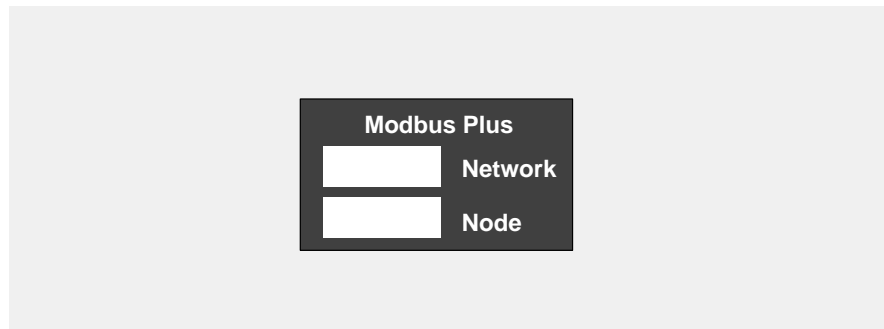

Figure 23 Modbus Plus Port Label

## 5.5.2 Serial Port Parameters Label

On this label enter the parameters you are using at each of the serial ports. Place the label on the BM85 so that it can readily identify the parameters in your application.

Figure 24 shows the layout of the label.

MODBUS	PORT 1	PORT 2	PORT 3	PORT 4
MASTER / NTKW / SLAVE (ADDRESS)				
ASCII / RTU				
BAUD RATE				
STOP BITS / PARITY				
TIMEOUT (100'S ms)				
MODEM BOOSTER				

Figure 24 Serial Port Parameters Label



# Appendix A

## Compatible Devices and Cables

---

- Compatible Devices and Cables
- Modbus/RS232 Cable Wiring Diagrams
- Modbus/RS232 Ports Pinout
- RS485 Ports Pinout

# A.1 Compatible Devices and Cables

---

## A.1.1 Abbreviations

These abbreviations are used in the device and cable listing. In the cable part numbers, 'XXX' indicates that a cable length option is available. Contact your Modicon distributor for further information.

### Modicon Devices and Cables

Abbreviation	Meaning
J375	Modicon Micro 84 Modbus communication option
J474	Modicon 484 Modbus communication option
J478	Modicon Modbus network option
W190	Modicon 584 Modbus cable assembly, AS-W190-XXX
W807	Modicon 884 Modbus cable assembly, AS-W807-XXX
W952	Modicon 984-680 to IBM AT cable assembly, AS-W952-XXX
W953	Modicon 984-680 to P230 cable assembly, AS-W953-XXX
W978	Modicon 984 to Modbus modem cable assembly, AS-W978-XXX

### Cable Adapters

Abbreviation	Meaning	Equivalent Part
9M9M	9-pin male to 9-pin male	Jameco GC9M
25F9M	25-pin female to 9-pin male	Jameco AD926
25F25F	25-pin female to 25-pin female	Jameco GC25F
X25F9M	25-pin female to 9-pin male, modified	Jameco AD926 remove connection between female pin 8 and male pin 1

Adapters are available from: Jameco Electronics, 1355 Shoreway Road, Belmont, CA 94002. Telephone: (415) 592-8097.

## A.1.2 Making 'Quick Connections'

The Modbus Plus inline connector (Modicon part AS-MBKT-085) is suitable for making simple 'single twisted pair plus shield' connections at a BM85 serial port.

Do *not* use a Modbus Plus terminating connector (AS-MBKT-185) in a serial cable application.

### A.1.3 Devices and Cables for Configuring Modbus Ports

Following is a listing of compatible devices and cables that can be used for configuring the ports on the BM85 Modbus models. Use of an IBM AT or XT computer requires a VT100 terminal emulation program, such as PROCOMM PLUS or equivalent. For further information contact: Datastorm Technologies, Inc., 1621 Towne Drive, Columbia, MD 65202. Telephone: (314) 474-8461.

Device	Cable and Adapter Combination
DEC VT100 (direct)	BM85 – W953 – 25F25F – VT100
DEC VT100 (modem)	BM85 – 25F9M – W978 – modem – modem – W978 – 25F25F – VT100
IBM AT (direct)	BM85 – W952 – IBM AT
IBM AT (modem)	BM85 – 25F9M – W978 – modem – modem – W978 – 25F9F – IBM AT
IBM XT (direct)	BM85 – W953 – 25F25F – IBM XT
IBM XT (modem)	BM85 – 25F9M – W978 – modem – modem – W978 – 25F25F – IBM XT

### A.1.4 Cables for Modbus Master Devices

Device	Cable and Adapter Combination
P230 (direct)	BM85 – W953 – P230
P230 (modem)	BM85 – 25F9M – W978 – J478 – J478 – P230
P965	BM85 – 25F9M – P965
IBM AT	BM85 – W952 – IBM AT
IBM XT	BM85 – W953 – 25F25F – IBM XT
Modvue	BM85 – W952 – J347 – Modvue
DEC VAX	BM85 – 25F9M with following signals crossed: TX/RX, RTS/CTS, DTR/DSR – VAX

### A.1.5 Cables for Modbus Slave Devices

Device	Cable and Adapter Combination
984–380/480/680/780	BM85 – 9M9M – W952 – 984
984A/B/X	BM85 – W953 – 984
584	BM85 – 25F9M – W190 – 584
884	BM85 – X25F9M – W807 – 884
Micro 84	BM85 – X25F9M – W807 – J375 – Micro 84
484	BM85 – 25F9M – W978 – J478 – J474 – 484
184/384	BM85 – W953 – J347 – 184/384
J478 modem	BM85 – 25F9M – W978 – J478 – J478 – Controller

# A.2 Modbus/RS232 Cable Wiring Diagrams

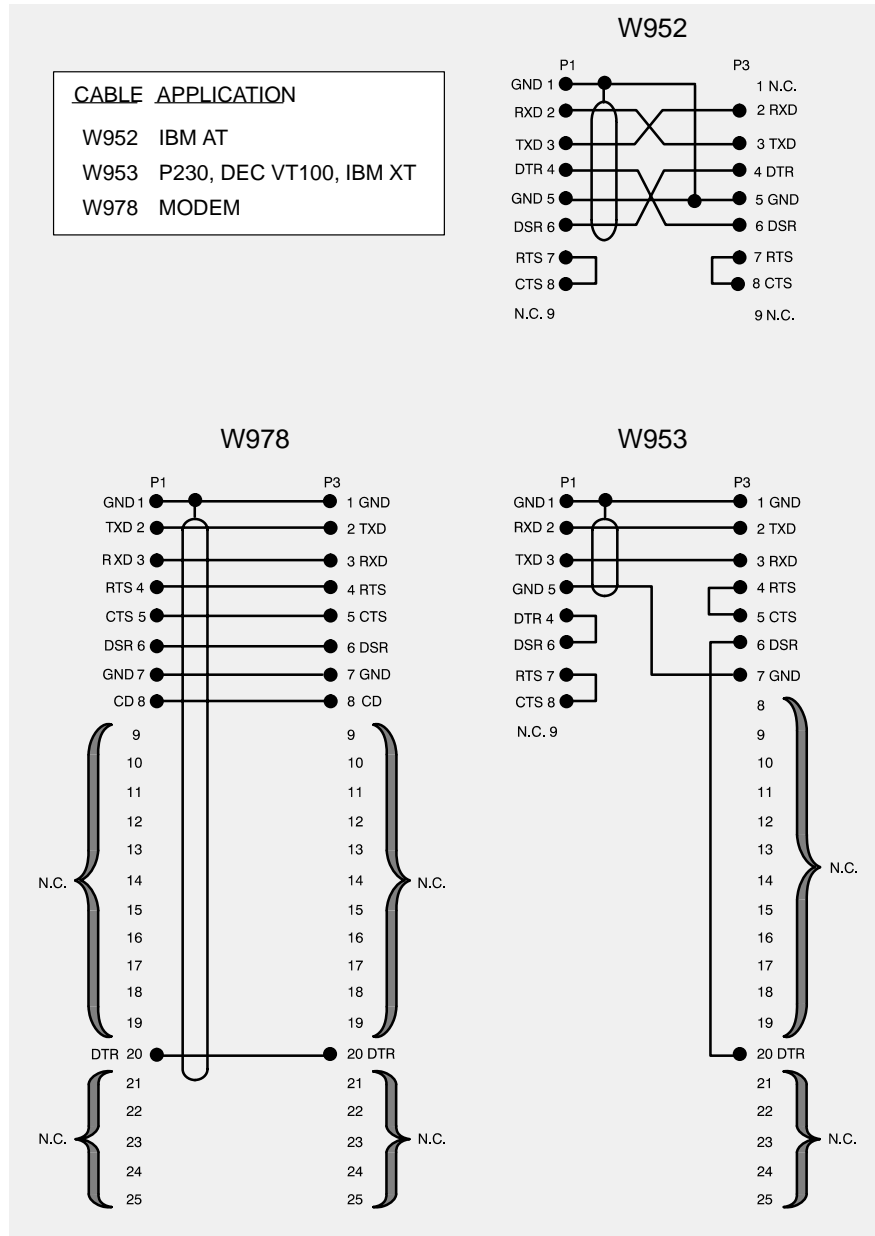



## A.3 Modbus/RS232 Ports Pinout

This section covers the serial ports pinout for the following models:

Part Number	Mounting Method	Operating Power (Nominal)	Modbus Plus Network Cable	Serial Ports	Serial Protocol
NW-BM85-000	Panel or Shelf	115/230 Vac	Single	Modbus	ASCII or RTU
NW-BM85C002	Panel or Shelf	115/230 Vac or 24 Vdc	Single or Dual	Modbus	ASCII or RTU
NW-BM85D008	19 in Rack	125 Vdc or 24 Vdc	Single or Dual	Modbus	ASCII or RTU
NW-BM85E232	Panel or Shelf	115/230 Vac or 24 Vdc	Single or Dual	RS232	Programmable, User Defined
NW-BM85D002	19 in Rack	125 Vdc or 24 Vdc	Single or Dual	RS232	Programmable, User Defined
NW-BM85S232	Panel or Shelf	115/230 Vac or 24 Vdc	Single or Dual	RS232	Programmable, User Defined

Figure 26 shows the pin configuration for the Modbus/RS232 port connectors. If you are fabricating cables for your application, the panel connector is a type DB9S.

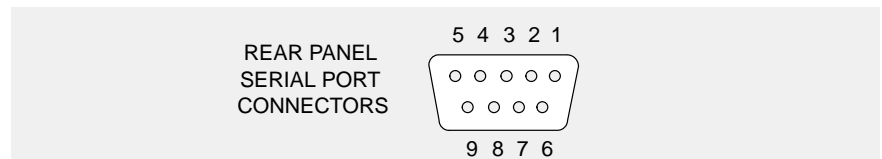

Figure 26 Serial Ports Pinout – Modbus/RS232

Pin	BM85 Direction	Purpose
1	—	Chassis ground
2	In	Receive data
3	Out	Transmit data
4	Out	Data Terminal Ready
5	—	Signal ground
6	In	Data Set Ready
7	Out	Request To Send
8	In	Clear To Send
9	—	not used

## A.4 RS485 Ports Pinout

This section covers the serial ports pinout for the following models:

Part Number	Mounting Method	Operating Power (Nominal)	Modbus Plus Network Cable	Serial Ports	Serial Protocol
NW-BM85E485	Panel or Shelf	115/230 Vac or 24 Vdc	Single or Dual	RS485	Programmable, User Defined
NW-BM85S485	Panel or Shelf	115/230 Vac or 24 Vdc	Single or Dual	RS485	Programmable, User Defined

Figure 27 shows the pin configuration for the RS485 port connectors. If you are fabricating cables for your application, the panel connector is a DB9S.

The Modbus Plus inline connector (part number AS-MBKT-085) is an acceptable substitute for an RS485 cable connector. Do *not* use a Modbus Plus terminating connector (AS-MBKT-185) in this application.

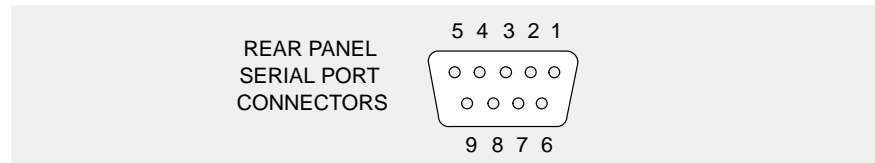

Figure 27 Serial Ports Pinout – RS485

Pin	BM85 Direction	Purpose
1	—	Chassis ground
2	In/Out	Receive/Transmit A
3	In/Out	Receive/Transmit B
4 ... 9	—	not used

# Glossary

---

**acknowledgement**

An LLC frame that indicates that a data frame has been received correctly.

**address**

On a network, the identification of a station. In a frame, a grouping of bits that identifies the frame's source or destination.

**ASCII**

American Standard Code for Information Interchange. A digital coding of alphanumeric and control characters as established by the American National Standards Institute.

**baud rate**

The speed of data transmission in serial data communications, approximately equal to the number of code elements (bits) per second.

**bit**

Binary Digit. The smallest unit of data, which can at any time be in one of two possible states, represented by a value of 0 or 1.

**bridge**

A device that interconnects two or more networks.

**Bridge Multiplexer**

A Modicon device that interconnects a Modbus Plus network with up to four Modbus devices or networks, or up to four RS232 or RS485 serial devices. See **Co-Processor**.

**Bridge Plus**

A Modicon device that interconnects two Modbus Plus networks.

**broadband**

A network communications method supporting multiple data transmission channels, using frequency division multiplexing.

**bus**

An electrical channel used to send or receive data.

**carrierband**

A network communications method in which information is transmitted using a single transmission channel. See **broadband**.

**channel**

The communication pathway between two or more devices.

**coaxial cable**

A two conductor cable in which an inner conductor is the signal path and an outer conductor is a shield. A dielectric separates the two conductors.

**Co-Processor**

Bridge Multiplexer models BM85S232 and BM85S485. These models contain a user-defined application program that can independently control processes at their four serial ports, accessing Modbus Plus nodes only as required.

**CRC**

Cyclic Redundancy Checking. An error detection method in which a sending station computes a mathematical value derived from the frame's contents, and sends it as an HDLC field in the frame. The receiving station recomputes the value as it receives the frame, and compares it to the received value. If the two values are equal, the frame is assumed to have been received without error.

**data frame**

An LLC frame containing data to be transferred between devices.

**Data Link Layer**

In the OSI model, the layer that provides services for transferring frames of data between nodes of a network. Defined by the IEEE 802.2 standard. At this layer, a sending device assembles data into a message packet with addresses and information for error checking, handles tokens for accessing the network, and sends the packet to the Physical Layer for transmission. Its two logical entities are the MAC and LLC sublayers. See **MAC** and **LLC**.

**DIO**

See **Distributed I/O**.

**DIO Drop Adapter**

See **DIO Adapter**.

**Distributed I/O**

A Modbus Plus network that consists of hardware components that are specifically designed for high-speed control of Input/Output devices at remote sites in an industrial process. Each DIO network has one Programmable Controller or one Modbus Plus Network Option Module that operates as the master controlling node on the network. The DIO network also has one or more DIO Adapters, placed at the remote plant sites. Up to 64 nodes can be present on each DIO network, exchanging messages during the passing of token frames.

**download**

The transfer of a program from one device to another for execution.

**drop cable**

A cable used to connect a networked node device to a tap on the trunk cable. Drop cables are available in various lengths from Modicon. See **tap**.

**duplicate frame**

A frame received twice because an acknowledgement was lost.

**end delimiter**

A field that defines the end of a message.

**EIA**

Electronic Industries Association.

**field**

A logical grouping of contiguous bits that convey one kind of information, such as the start or end of a message, an address, data, or an error check.

**frame**

A logical grouping of contiguous bits for transmission; a message.

**frame check sequence**

A code that is used to determine whether a frame was received correctly.

**frame descriptor**

A part of the host computer's buffer structure that links transmitted or received data frames to appropriate priority queues. Frame Descriptors contain MAC frame parameters, frame status, and pointers.

**Global Input**

A type of data input received by a node using Peer Cop data transfers. Nodes using Peer Cop can be configured to receive up to 32 16-bit words of Global Input data from each of up to 64 source nodes, up to a maximum total of 500 words. Incoming data from each source node can be indexed into up to eight fields for delivery into separate data destinations in the receiving node.

**Global Output**

A type of data output sent by a node using Peer Cop data transfers. Nodes using Peer Cop can be configured to send up to 32 16-bit words of Global Output data, which is globally broadcast to all active nodes on the network. Destination nodes can be configured to accept or ignore incoming data from specific source nodes.

**HDLC**

High-level Data Link Control. The part of the device that performs the protocols for defining the beginning and end of a frame, synchronizing the frame between sender and receiver, providing CRC error checking, and defining the portion of the received information that is to be checked by the CRC.

**host computer**

A computer which controls other computers and devices. In an industrial process with networking, the host computer specifies the current requirements for the operation of remote nodes, and is the destination for summary data reports about the performance of the process.

**IEC**

International Electrical Commission.

**IEEE**

Institute of Electrical and Electronics Engineers.

**ISO**

International Standards Organization.

**LAN**

Local Area Network. An interconnection of devices in which data is transferred without the use of public communications services. Modbus Plus is an example of a LAN for controlling and monitoring industrial processes.

**layer**

In the OSI Model, a portion of the structure of a device which provides defined services for the transferring of information. See **Data Link Layer** and **Physical Layer**.

**LLC**

Logical Link Control. The part of the device that performs the protocols for identifying users of the network and for providing reliable frame delivery. The LLC handles the framing and checking of messages.

**MAC**

Medium (or Media) Access Control. The part of the device that performs the protocols for sharing the network with other devices. The MAC handles the queueing and transmission of outgoing LLC level messages, address recognition for incoming messages, and resolution of access contentions.

**MAP**

Manufacturing Automation Protocol. A network protocol that allows devices or cells within an industrial environment to communicate with each other.

**master**

A networked device which controls other devices to which it connects. It initiates transactions, and schedules and transmits tasks to a slave device. See **slave**.

**medium**

The entire cable system: the network cable, taps, connectors, and terminators.

**Modbus**

An industrial networking system that uses RS232 serial master-slave communications at data transfer rates of up to 19.2 k baud.

**Modbus Plus**

An industrial networking system that uses token-passing peer-to-peer communications at data transfer rates of one megabits per second. The network medium is shielded twisted-pair cable.

**Modbus II**

An industrial networking system that uses token-passing peer-to-peer communications at data transfer rates of five megabits per second. The network medium is coaxial cable.

**modem**

Modulator/demodulator. A device that conditions digital data for transmission along an analog signal path, or conditions input signals received from the path for use as digital data.

**network**

The interconnection of devices sharing a common data path and protocol for communication. On Modbus Plus, the devices share in the passing of a common token frame to gain sequential access for sending messages.

**Network Option Module**

A hardware module that is mounted into a common backplane together with a Programmable Controller, communicating with the controller over the backplane. The module connects to the Modbus Plus network and provides the central point for communication between the controller's application program and the node devices on the network.

**node**

A device that has a direct point of access to a communications network. On Modbus Plus, any device that is physically connected to the network.

**OSI Model**

Open Systems Interconnection Model. A reference standard describing the required performance of devices for data communication. Produced by the International Standards Organization.

**Peer Cop**

A method of peer-to-peer communication between networked devices in which data is transferred as part of the passing of tokens between nodes. Each node passes the token in the network's address sequence, and can be configured to transmit data in addition to the token. All nodes monitor the token passes, and can be configured to extract data from them. Nodes are setup for Peer Cop transfers as part of their initial configuration, and continue using Peer Cop as long as they are active on the network. Four kinds of Peer Cop communication can be transacted during each token pass: see **Global Input**, **Global Output**, **Specific Input**, and **Specific Output**.



**peer-to-peer communication**

A communication between networked devices in which any device can initiate data transfer. The method used by devices conforming to the OSI Model. Also the method used on Modbus Plus.

**Physical Layer**

In the OSI model, the layer that provides the physical connection and signalling means between nodes of a network. Defined by the IEEE 802.4 standard.

**port**

The external connector on a device at which the network cable is attached.

**protocol**

A set of rules used mutually by two or more devices to communicate.

**Repeater**

A Modicon device that interconnects two sections of a Modbus Plus network.

**routing path**

In Modbus Plus, the sequence of device node addresses through which a message will be routed to its final destination.

**routing path field**

In a Modbus Plus message frame, a group of five bytes that specify the addresses of the devices in the message routing path.

**RS232**

An EIA standard that defines signal requirements and cable connections for serial data communications, characterized by single wires for transmitted data and received data.

**RS485**

An EIA standard that defines signal requirements and cable connections for serial data communications, characterized by a balanced pair of wires for both transmitted and received data.

**section**

A contiguous grouping of cable segments, together with their node devices, connected directly to form a signal path that does not pass through any Repeater. The minimum length of a section can be 10ft (3m), the same as one segment. The maximum length can be 1500 ft (450 m). One section supports up to 32 nodes.

**segment**

The combination of: a continuous length of trunk cable connecting a pair of taps; the two taps; and the drop cables between the two taps and their node devices. One or more segments form a section of the network. See **section** and **tap**.

**serial port**

An communication port at which data is transferred one bit at a time.

**slave**

A networked device which is controlled by another device. Slave devices do not initiate data transactions. They respond to commands or requests initiated by a master device. See **master**.

**slot time**

The amount of time representing the worst case time any station on the network must wait for a response from another station. It is based upon the response time of the network's slowest station and the bus propagation delay.

**Specific Input**

A type of data input received by a node using Peer Cop data transfers. Nodes using Peer Cop can be configured to receive up to 32 16-bit words of Specific Input data from each of up to 64 source nodes, up to a maximum total of 500 words. Nodes can be configured to accept or ignore incoming data from specific source nodes.

**Specific Output**

A type of data output sent by a node using Peer Cop data transfers. Nodes using Peer Cop can be configured to send up to 32 16-bit words of Specific Output data to each of up to 64 destination nodes, up to a maximum total of 500 words.

**splitter**

A passive device that allows a cable to be routed into multiple paths with essentially equal signal amplitude in each path. Not used with Modbus Plus.

**start delimiter**

A field that defines the start of a frame, occurring after the signal has been detected and synchronized by the receiving node. See **end delimiter**.

**system**

A set of hardware devices and their associated software capable of performing the functions of information processing and device control without significant dependence on other equipment.

**tap**

A passive electrical device that joins segments of the trunk cable, or terminates the trunk cable at its two end sites. It also provides a connection for the drop cable to the node device at the tap site. See **terminator**.

**terminator**

A resistive load placed at the end of a cable to prevent data signals from reflecting back into the data path. The signals are terminated with the same impedance as the characteristic impedance of cable system. On Modbus Plus, each tap contains a terminating resistor with two jumpers. The termination is effective when the jumpers are installed. The tap at each of the two ends of the cable section has its terminating jumpers installed. The tap at each inline point has them removed. See **section**.

**token**

In data transmission, a frame passed on a network that gives a networked device the current authority to transmit.

**token bus**

A network access method between two or more devices in which the procedure for sending data is based upon the passing of a token for access to the network. See **token**.

**transaction**

The complete and successful transfer of a message between networked devices.

**trunk**

The main element of the cable system that interconnects the network nodes. On Modbus Plus, the trunk cable runs directly between pairs of taps.



# Index

---

- A**
- addressing
  - examples, 22
  - Modbus address conversion, 20, 36
  - on Modbus Plus, 18
- B**
- BM85
  - available models, 4
  - introduction, 2
  - Modbus port models, 10
  - programmable models, 6
  - specifications, 12, 14
- C**
- cables
  - for serial ports, 84
  - network connections, 76
  - power connections, 74
  - serial port connections, 76
  - wiring diagrams, 86
- configuration
  - configuration overview, 5
  - development software
    - availability, 9
    - description, 60
    - installing, 62
    - part numbers, 13, 15
    - README.DOC file, 60
  - downloading to BM85, 64
  - Modbus port models, 26, 28, 40
    - commands, 42
    - Communications parameters, 31
    - configuration overview, 26
    - default settings, 43
    - devices and cables, 84
    - Link Timeout parameter, 32
    - Modbus Address Map, 36
    - Modem Booster parameter, 34
    - port parameters, 29
    - Port Priority parameter, 31
    - Port Type parameter, 30
    - RUN mode, 53
    - Slave Device Address parameter, 31
  - programmable models, 58
    - configuration overview, 8, 58
    - RUN mode, 68
  - required equipment
    - for Modbus port models, 27
    - for programmable models, 13, 15, 59
- D**
- development software, *see* configuration
- dimensions
  - rack mounted models, 73
  - shelf/panel models, 72
- downloading
  - error codes, 67
  - normal indications, 67
  - preparing the BM85, 64
- E**
- error codes
  - Modbus port models, 54
  - programmable port models, 67
- F**
- front/top view
  - rack mount models, 73
  - shelf/panel mount models, 72
- I**
- indicators, 78
  - Modbus and Serial Port status, 78
  - Modbus Plus network status, 79
  - Power and Ready status, 78
- L**
- labels
  - for port identification, 80
  - required for cables, 76

## **M**

- Modbus Plus communication
  - overview, 2
  - status indicators, 79
- Modbus Plus network, routing paths, 18
- Modicon
  - Customer Service, 9
- mounting methods, 70
  - horizontal mounting, 71
  - overview, 4
  - rack mounted models, 71
  - shelf/panel models, 70
  - vertical mounting, 71

## **N**

- network cables, connecting, 76

## **O**

- operating power
  - ac connections, 74
  - connecting, 74
  - connector layouts
    - BM85-000, 75
    - BM85C, BM85E, BM85S, 75
    - BM85D, 75
  - dc connections, 74
  - overview, 5
- overview, BM85 models, 4

## **P**

- part numbers
  - BM85 models, 4
  - cables, 84
  - development software, 13, 15

## **R**

- rear panel view, 75
- RUN mode
  - Modbus port models, 53
  - programmable models, 68

## **S**

- screens, Modbus port models, 44
  - V1 screen, 46
  - V2, V3 screen, 48
  - V4 screen, 50
- serial port cables, connecting, 76
- serial ports
  - devices and cables, 84
  - Modbus/RS232 pinout, 87
  - RS485 pinout, 88
- silent master port, 30, 39
- specifications
  - ac/dc models, 12
  - dc/dc models, 14
- switch setup
  - Modbus port models, 40, 52
  - programmable models, 65, 66

## **T**

- top/front view
  - rack mount models, 73
  - shelf/panel mount models, 72