



## Load Sharing Module

**Pulse Width Modulated Output  
9907-175, 9907-838**

**Installation and Operation Manual**



### General Precautions

Read this entire manual and all other publications pertaining to the work to be performed before installing, operating, or servicing this equipment.

Practice all plant and safety instructions and precautions.

Failure to follow instructions can cause personal injury and/or property damage.



### Revisions

This publication may have been revised or updated since this copy was produced. To verify that you have the latest revision, check manual **26311**, *Revision Status & Distribution Restrictions of Woodward Technical Publications*, on the *publications page* of the Woodward website:

[www.woodward.com/publications](http://www.woodward.com/publications)

The latest version of most publications is available on the *publications page*. If your publication is not there, please contact your customer service representative to get the latest copy.



### Proper Use

Any unauthorized modifications to or use of this equipment outside its specified mechanical, electrical, or other operating limits may cause personal injury and/or property damage, including damage to the equipment. Any such unauthorized modifications: (i) constitute "misuse" and/or "negligence" within the meaning of the product warranty thereby excluding warranty coverage for any resulting damage, and (ii) invalidate product certifications or listings.



### Translated Publications

If the cover of this publication states "Translation of the Original Instructions" please note:

The original source of this publication may have been updated since this translation was made. Be sure to check manual **26311**, *Revision Status & Distribution Restrictions of Woodward Technical Publications*, to verify whether this translation is up to date. Out-of-date translations are marked with . Always compare with the original for technical specifications and for proper and safe installation and operation procedures.

**Revisions**—Changes in this publication since the last revision are indicated by a black line alongside the text.

Woodward reserves the right to update any portion of this publication at any time. Information provided by Woodward is believed to be correct and reliable. However, no responsibility is assumed by Woodward unless otherwise expressly undertaken.

# Contents

<b>WARNINGS AND NOTICES .....</b>	<b>III</b>
<b>ELECTROSTATIC DISCHARGE AWARENESS .....</b>	<b>IV</b>
<b>CHAPTER 1. GENERAL INFORMATION.....</b>	<b>1</b>
Introduction .....	1
Description .....	1
<b>CHAPTER 2. INSTALLATION.....</b>	<b>5</b>
Introduction .....	5
Unpacking .....	5
Location Considerations .....	5
General Wiring Requirements .....	6
Power Requirements .....	6
Shielded Wiring .....	7
Generator Connections .....	8
Current Transformers .....	8
Load Sharing Lines, Droop, and Auxiliary Contacts.....	8
Output to the Caterpillar Digital Electronic Control.....	9
Synchronization Connections .....	9
Speed Trim Potentiometer.....	9
<b>CHAPTER 3. SETUP AND CALIBRATION .....</b>	<b>10</b>
Introduction .....	10
Phasing Check .....	11
Phase Correction Procedure .....	12
Load Gain Adjustment.....	15
Droop Adjustment.....	16
Setting Droop for an Isolated Load.....	16
Setting Droop for an Infinite Bus .....	17
<b>CHAPTER 4. THEORY OF OPERATION .....</b>	<b>18</b>
Introduction .....	18
Power Supply .....	18
Power Sensor .....	18
Load Comparator Circuit .....	18
Speed Trim Circuit.....	19
Isochronous Load Sharing.....	19
Droop Operation .....	19
Auxiliary Equipment.....	19
Pulse Width Modulation.....	19
<b>CHAPTER 5. TROUBLESHOOTING .....</b>	<b>20</b>
<b>CHAPTER 6. SERVICE OPTIONS .....</b>	<b>22</b>
Product Service Options.....	22
Woodward Factory Servicing Options .....	23
Returning Equipment for Repair .....	23
Replacement Parts .....	24
Engineering Services.....	24
How to Contact Woodward.....	25
Technical Assistance.....	25
<b>APPENDIX. LSM CONTROL SPECIFICATIONS.....</b>	<b>26</b>
<b>REVISION HISTORY.....</b>	<b>28</b>
<b>DECLARATIONS.....</b>	<b>29</b>

## Illustrations and Tables

Figure 1-1. Typical System Using a Load Sharing Module .....	1
Figure 1-2. Outline Drawing of Load Sharing Module .....	2
Figure 1-3. Plant Wiring Diagram of Load Sharing Module.....	3
Figure 1-4. Block Diagram of Load Sharing Module .....	4
Figure 2-1. Preparation of Shielded Cables .....	7
Figure 3-1. Temporary CT Connections .....	13
Figure 3-2. Droop Adjustment .....	16

## Warnings and Notices

### Important Definitions



This is the safety alert symbol. It is used to alert you to potential personal injury hazards. Obey all safety messages that follow this symbol to avoid possible injury or death.

- **DANGER**—Indicates a hazardous situation which, if not avoided, will result in death or serious injury.
- **WARNING**—Indicates a hazardous situation which, if not avoided, could result in death or serious injury.
- **CAUTION**—Indicates a hazardous situation which, if not avoided, could result in minor or moderate injury.
- **NOTICE**—Indicates a hazard that could result in property damage only (including damage to the control).
- **IMPORTANT**—Designates an operating tip or maintenance suggestion.

#### **WARNING**

**Overspeed /  
Overtemperature /  
Overpressure**

The engine, turbine, or other type of prime mover should be equipped with an overspeed shutdown device to protect against runaway or damage to the prime mover with possible personal injury, loss of life, or property damage.

The overspeed shutdown device must be totally independent of the prime mover control system. An overtemperature or overpressure shutdown device may also be needed for safety, as appropriate.

#### **WARNING**

**Personal Protective  
Equipment**

The products described in this publication may present risks that could lead to personal injury, loss of life, or property damage. Always wear the appropriate personal protective equipment (PPE) for the job at hand. Equipment that should be considered includes but is not limited to:

- Eye Protection
- Hearing Protection
- Hard Hat
- Gloves
- Safety Boots
- Respirator

Always read the proper Material Safety Data Sheet (MSDS) for any working fluid(s) and comply with recommended safety equipment.

#### **WARNING**

**Start-up**

Be prepared to make an emergency shutdown when starting the engine, turbine, or other type of prime mover, to protect against runaway or overspeed with possible personal injury, loss of life, or property damage.

#### **WARNING**

**Automotive  
Applications**

On- and off-highway Mobile Applications: Unless Woodward's control functions as the supervisory control, customer should install a system totally independent of the prime mover control system that monitors for supervisory control of engine (and takes appropriate action if supervisory control is lost) to protect against loss of engine control with possible personal injury, loss of life, or property damage.

**NOTICE****Battery Charging  
Device**

To prevent damage to a control system that uses an alternator or battery-charging device, make sure the charging device is turned off before disconnecting the battery from the system.

## Electrostatic Discharge Awareness

**NOTICE****Electrostatic  
Precautions**

Electronic controls contain static-sensitive parts. Observe the following precautions to prevent damage to these parts:

- Discharge body static before handling the control (with power to the control turned off, contact a grounded surface and maintain contact while handling the control).
- Avoid all plastic, vinyl, and Styrofoam (except antistatic versions) around printed circuit boards.
- Do not touch the components or conductors on a printed circuit board with your hands or with conductive devices.

To prevent damage to electronic components caused by improper handling, read and observe the precautions in Woodward manual **82715**, *Guide for Handling and Protection of Electronic Controls, Printed Circuit Boards, and Modules*.

Follow these precautions when working with or near the control.

1. Avoid the build-up of static electricity on your body by not wearing clothing made of synthetic materials. Wear cotton or cotton-blend materials as much as possible because these do not store static electric charges as much as synthetics.
2. Do not remove the printed circuit board (PCB) from the control cabinet unless absolutely necessary. If you must remove the PCB from the control cabinet, follow these precautions:
  - Do not touch any part of the PCB except the edges.
  - Do not touch the electrical conductors, the connectors, or the components with conductive devices or with your hands.
  - When replacing a PCB, keep the new PCB in the plastic antistatic protective bag it comes in until you are ready to install it. Immediately after removing the old PCB from the control cabinet, place it in the antistatic protective bag.

# Chapter 1. General Information

## Introduction

The Woodward Load Sharing Module is made for use with Caterpillar engines equipped with a Caterpillar digital speed control with a pulse width modulated (PWM) input. The Load Sharing Module allows use of Woodward power generation accessories and allows load sharing between the Caterpillar digital speed control equipped engines and engines controlled with Woodward electronic controls.

<u>Part Number</u>	<u>Power Supply</u>	<u>PWM Output Surge Protection</u>
9907-175	24 Vdc	No
9907-838	24 Vdc	Yes

## Description

The Load Sharing Module provides isochronous and droop load-sharing capability for engines equipped with Caterpillar digital controls in generator set applications. Additional equipment in the control system can include the Woodward SPM-A Synchronizer, Paralleling Phase Switch, Import/Export Control, Precision Frequency Control, Automatic Generator Loading Control, and Automatic Power Transfer and Loading Control.

Figure 1-1 shows a typical system using a Load Sharing Module.

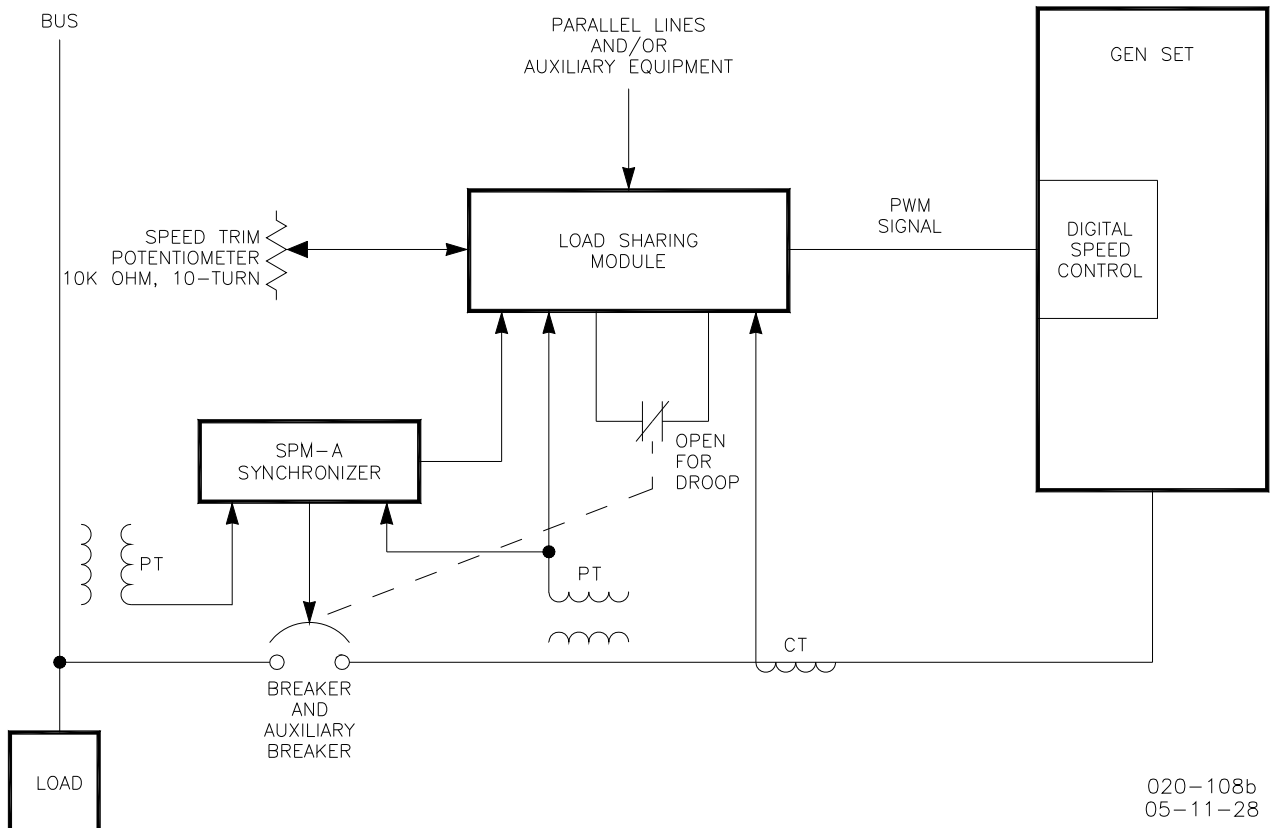

020-108b  
05-11-28

Figure 1-1. Typical System Using a Load Sharing Module

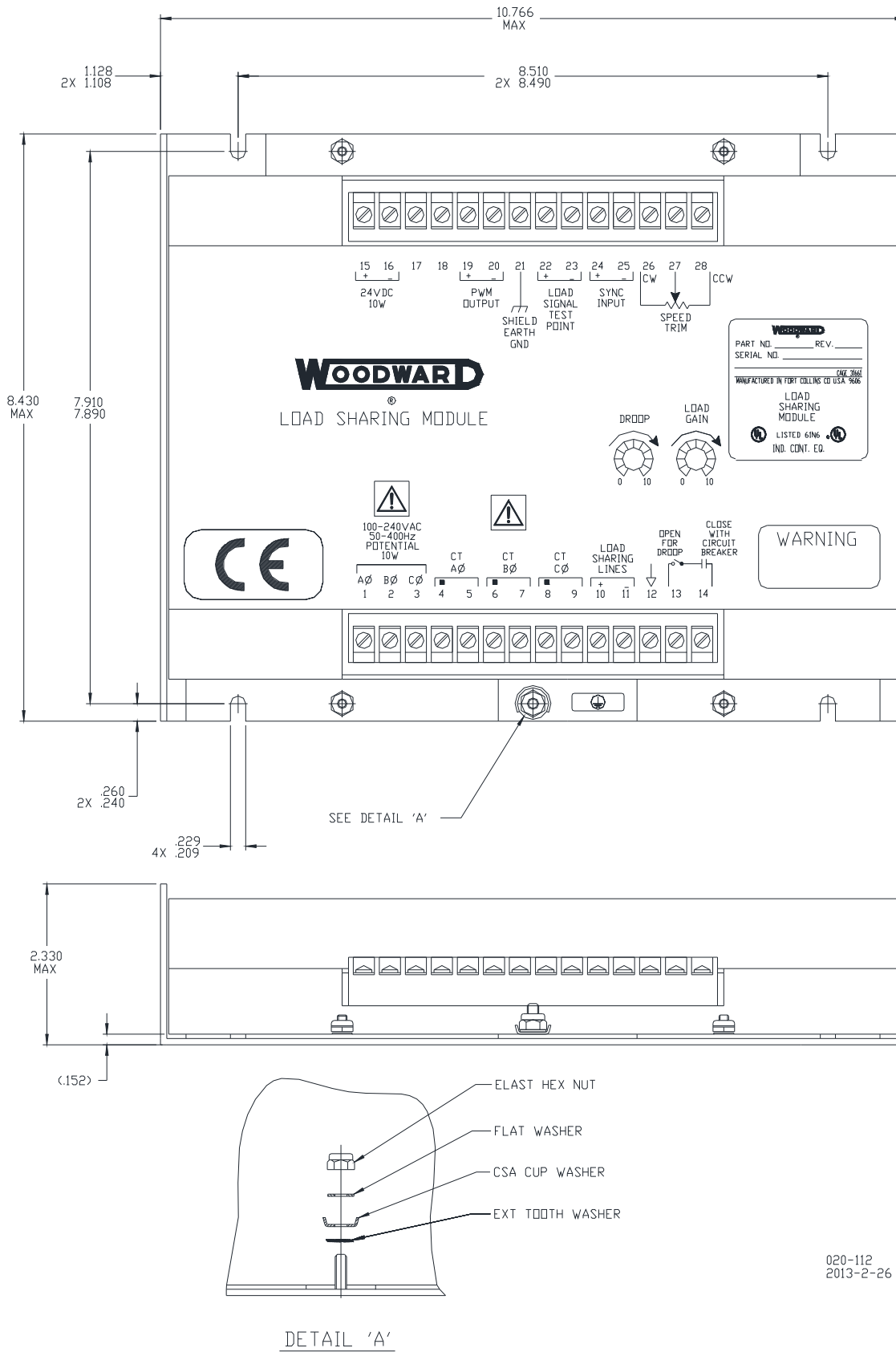

020-112  
2013-2-26

Figure 1-2. Outline Drawing of Load Sharing Module (Do Not Use For Construction)



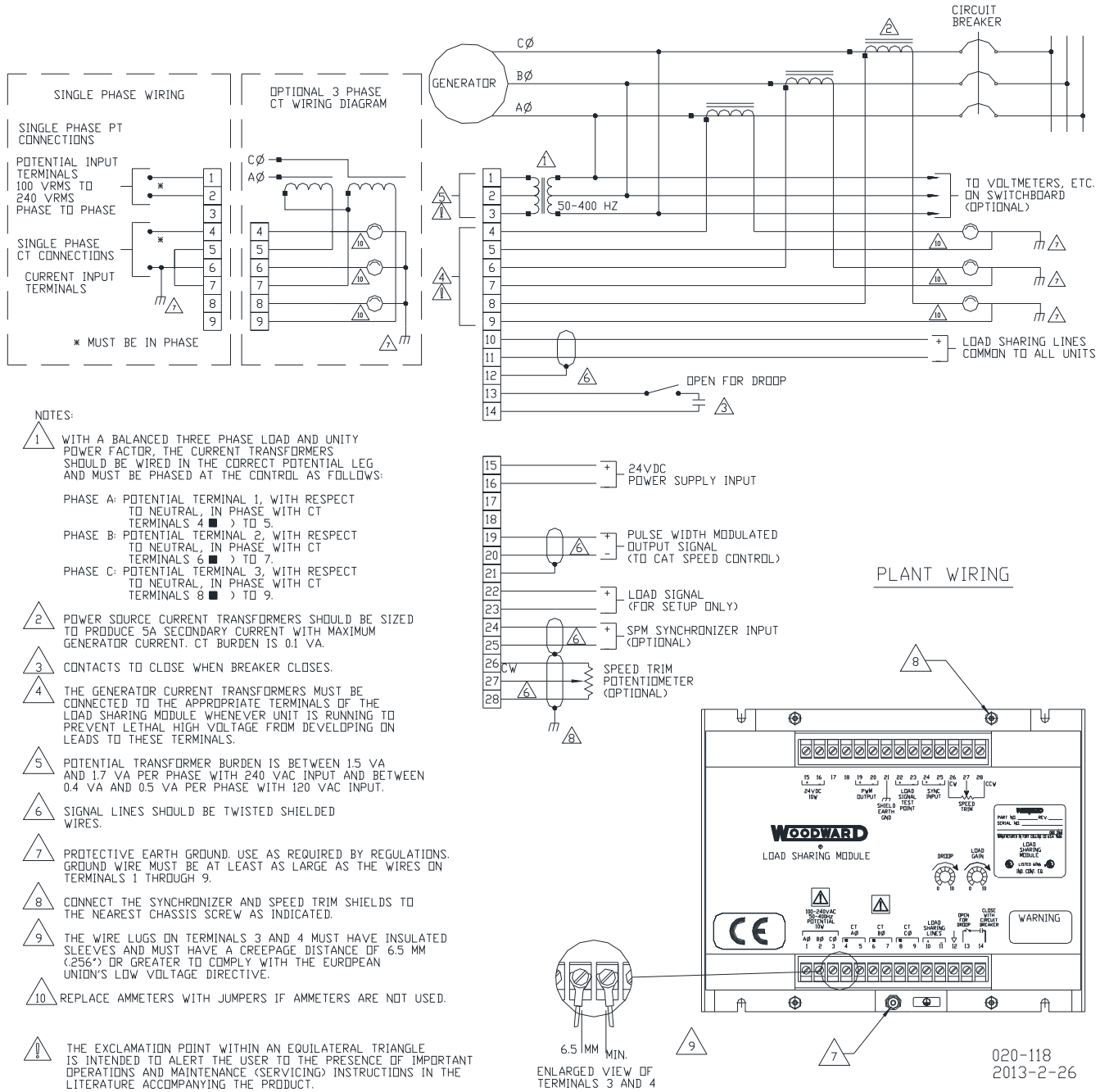
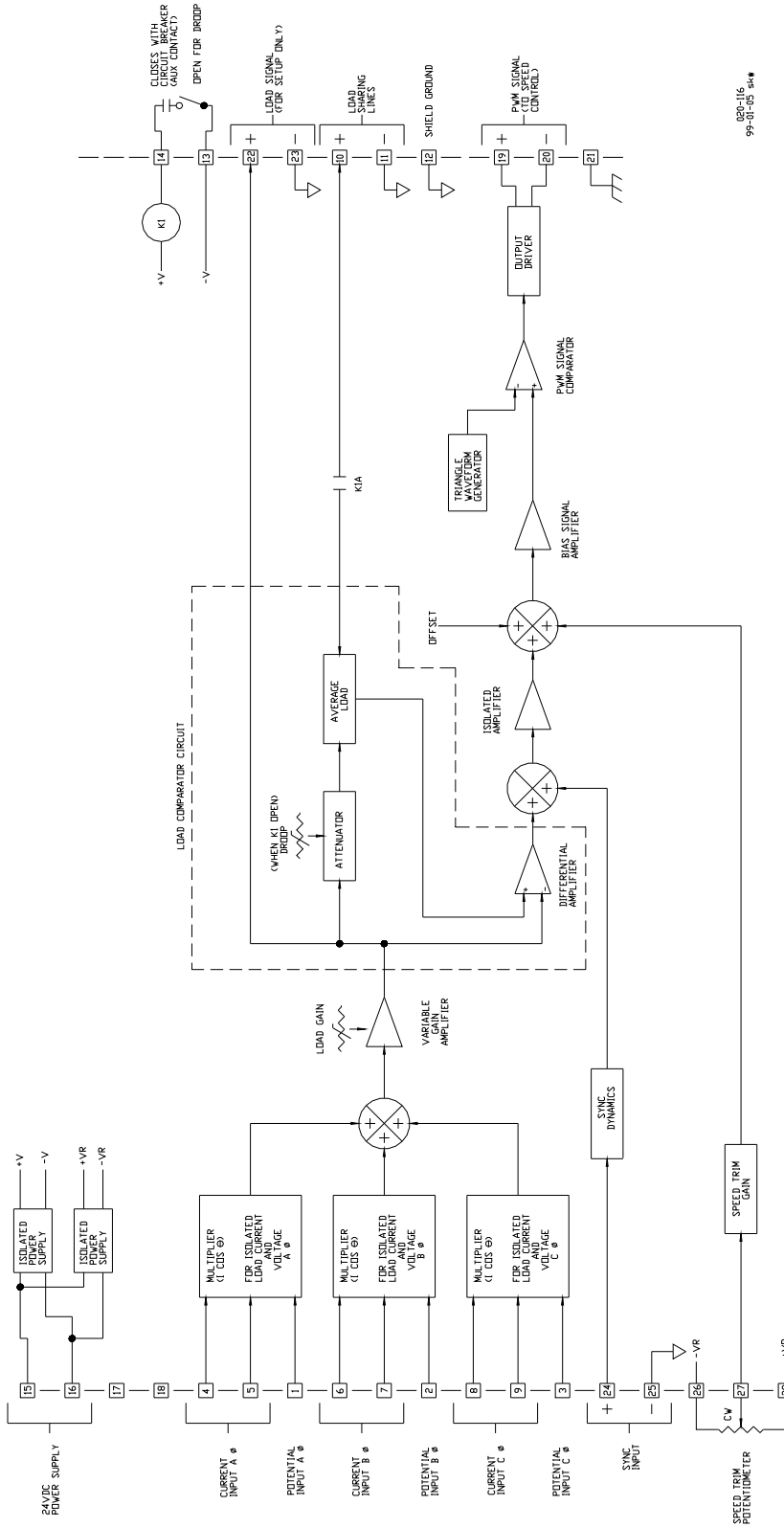

Figure 1-3. Plant Wiring Diagram of Load Sharing Module



020-116  
99-01-05 5414

Figure 1-4. Block Diagram of Load Sharing Module

## Chapter 2. Installation

### Introduction

This section contains general installation instructions for the Load Sharing Module. Environmental precautions and location considerations are included to determine the best location for the Load Sharing Module. Additional information includes unpacking instructions, electrical connections, and an installation check-out procedure.

### Unpacking

Before handling the Load Sharing Module, read page iii, Electrostatic Discharge Awareness. Be careful when unpacking the Load Sharing Module. Check the unit for signs of damage such as bent or dented panels, scratches, and loose or broken parts. Notify the shipper of any damage.

### Location Considerations

Consider these requirements when selecting the mounting location:

- Adequate ventilation for cooling
- Space for servicing and repair
- Protection from direct exposure to water or to a condensation-prone environment
- Protection from high-voltage or high-current devices, or devices which produce electromagnetic interference
- Protection from excessive vibration
- An ambient operating temperature range of  $-40$  to  $+70$  °C ( $-40$  to  $+158$  °F)
- All wiring to/from the Load Sharing Module should be limited to 30 m (98 ft) in length.

**Do not mount the Load Sharing Module on the engine.**

Figure 1-2 is an outline drawing of the Load Sharing Module. Install the unit near the electronic engine control. It may be installed in any position.

To maintain compliance with CE marking requirements, the European Union Low Voltage Directive requires that the Load Sharing Module (LSM) be mounted in an IP43 enclosure as defined in EN60529. Access to the Load Sharing Module must be restricted to qualified personnel.

## General Wiring Requirements



The circled ground symbol identifies the Protective Earth Terminal. This terminal must be connected directly to protective earth using a grounding conductor at least as large as those used on terminals 1 through 9. The insulation of the grounding conductor must be of green and yellow color.



This symbol identifies functional or EMC earth. This terminal is to be used for cable shield connections only. It is not to be used as a protective earth terminal.

### IMPORTANT

**When attaching a grounding connection, it is essential that the grounding ring lug or spade lug be connected between the flat washer and the CSA cup washer, and that the external tooth washer remain between the mounting base and the CSA cup washer. See Detail 'A' in Figure 1-2.**

External wiring connections and shielding requirements for a typical installation are shown in the plant wiring diagram, Figure 1-3. These wiring connections and shielding requirements are explained in more detail in this chapter.

To maintain compliance with CE marking requirements, the Low Voltage Directive requires that the Load Sharing Module must only be connected to Class III equipment.

Wiring for the Load Sharing Module must be suitable for at least 90 °C (194 °F) and also be suitable for the maximum installed operating temperature.

The Load Sharing Module must be permanently connected and employ fuses or circuit breakers in each of the PT lines to limit current to the LSM PT inputs to no more than 5 A. In addition, a 2 A fast-acting fuse or circuit breaker must be provided in the 24 Vdc power supply line.

All terminal block screws must be tightened to 0.56 to 0.79 N·m (5.0 to 7.0 lb-in).

To maintain compliance with CE marking requirements, the EMC Directive requires that all shields be connected to the terminals provided per the plant wiring diagram, Figure 1-3.

Wiring for the Load Sharing Module should not exceed 30 m (98 ft) in length. If any signal run must exceed this limit, an isolator must be used within 30 m of the Load Sharing Module. The isolator must provide galvanic isolation via optical or magnetic means.

## Power Requirements

The Load Sharing Module is powered from a 24 Vdc source. The 24 Vdc source must be a minimum of 18 Vdc and a maximum of 32 Vdc continuous. If a battery is used for operating power, an alternator or other battery charging device is necessary to maintain a stable supply voltage.

### NOTICE

**To prevent possible serious damage to the Load Sharing Module, make sure the alternator or other battery charging device is turned off or disconnected before disconnecting the battery from the unit.**

## Shielded Wiring

All shielded cable must be twisted conductors with either a foil or braided shield. Do not attempt to tin (put solder on) the braided shield. All signal lines should be shielded to prevent picking up stray signals from adjacent equipment. Connect the shields to the terminals indicated in the plant wiring diagram. Wire exposed beyond the shield must be as short as possible.

The other end of the shields must be left open and insulated from any other conductor. Do not run shielded signal wires with other wires carrying large currents. See Woodward application note 50532, *EMI Control in Electronic Governing Systems*, for more information.

Where shielded cable is required, cut the cable to the desired length and prepare the cable as instructed below and shown in Figure 2-1.

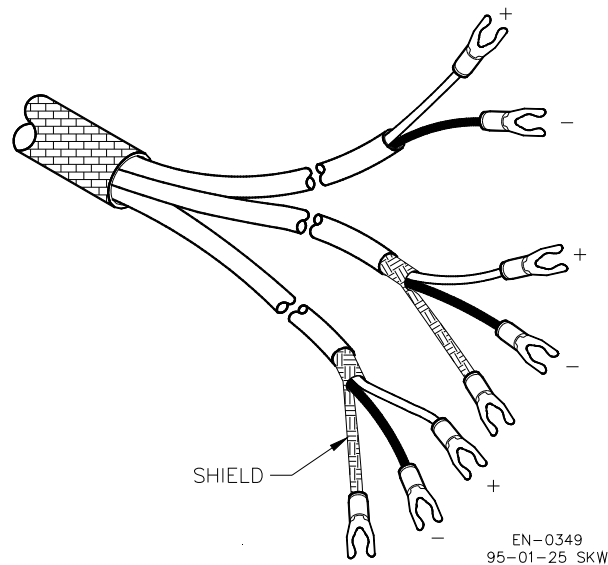

Figure 2-1. Preparation of Shielded Cables

1. Strip outer insulation from both ends, exposing the braided or spiral wrapped shield. Do not cut the shield on the end nearest to the Load Sharing Module. Cut off the shield on the end away from the unit.
2. Use a sharp, pointed tool to carefully spread the strands of the shield.
3. Pull the inner conductors out of the shield. Twist braided shields to prevent fraying. The breakout length of the shield braid should be 51 mm (2 inches) or less.
4. Connect lugs to the shield and to the control wires. Number 6 slotted or round crimp-on terminals are used for most installations. Connect the wires to the appropriate terminals on the module.

Installations with severe electromagnetic interference (EMI) may require shielded wire run in conduit, double shielded wire, or other precautions.

## Generator Connections

**IMPORTANT**

Use 1 mm<sup>2</sup> (18 AWG) or larger wire for all PT and CT connections.

The spacing between the lugs on terminals 3 and 4 must be 6.5 mm (0.256 inch) or greater to comply with the European Union Low Voltage Directive (see Figure 1-3). The lugs must have insulated sleeves.

**IMPORTANT**

Connections from the potential transformers and current transformers must be made correctly in regard to the three phases for the Load Sharing Module to operate correctly. Sorting out the three phases at the module is tedious and requires numerous generator starts and stops. If at all possible, make sure that the wiring is correctly done at the time of installation and the phases correctly and permanently identified at the generator and at the module.

Connect the PT output from the A leg to terminal 1. Connect the PT output from the B leg to terminal 2. Connect the PT output from the C leg to terminal 3. Size the potential transformers to produce 100–240 Vac.

## Current Transformers

Power source current transformers should be sized to produce 5 A secondary current with maximum generator current (3–7 A secondary current at full load is acceptable). CT burden is 0.1 VA. To prevent lethal high voltage from developing on leads to the terminals, the Load Sharing Module contains internal burden which must be connected across the power source current transformers whenever the unit is running. Ammeters may be installed on the leads from the current transformers.

Connect phase “A” CT to terminals 4 and 5. Connect phase “B” CT to terminals 6 and 7. Connect Phase “C” CT to terminals 8 and 9. Observe correct phasing as shown in the plant wiring diagram, Figure 1-3.

## Load Sharing Lines, Droop, and Auxiliary Contacts

The droop contact for selecting droop or isochronous operation is wired in series with the circuit breaker auxiliary contact between terminals 13 and 14. When both the droop contact and circuit breaker auxiliary contact are closed, the Load Sharing Module is in the isochronous load sharing mode. In this mode the internal load-sharing-line relay is energized, the droop signal is disabled, and the load matching circuit is connected to the load-sharing lines, permitting isochronous load sharing.

The Load Sharing Module is in the droop mode when EITHER the droop contact or the circuit breaker auxiliary contact is open. If the droop contact is open, the Load Sharing Module remains in the droop mode even when the circuit breaker auxiliary contact is closed. If droop is not desired when the auxiliary contact is open, turn the droop potentiometer fully counterclockwise.

Use a single pole, single-throw switch with a 0.1 A minimum rating for the “open for droop” switch.

Use twisted 0.5 mm<sup>2</sup> (20 AWG) or larger shielded wire to connect the load sharing lines to the other Load Sharing Modules. Connect the (+) wire from the other Load Sharing Modules to terminal 10. Connect the (-) wire from the other Load Sharing Modules to terminal 11. Connect the shield of the load share wiring to terminal 12. The shield should always be connected only to terminal 12. No other shields should be connected to this terminal.

## Output to the Caterpillar Digital Electronic Control

Use twisted 0.5 mm<sup>2</sup> (20 AWG) or larger shielded wire to connect the pulse-width modulated output signal from terminals 19(+) and 20(-) to the Caterpillar control. Connect the shield to terminal 21 only. Do not connect the shield at the Caterpillar control end of the wiring.

## Synchronization Connections

If an SPM-A synchronizer is used, connect twisted-pair 0.5 mm<sup>2</sup> (20 AWG) or larger shielded wire from the synchronizer to terminals 24(+) and 25(-). Tie the shield to terminal 21. Do not connect the shield at the synchronizer end of the wiring.

## Speed Trim Potentiometer

If a speed-trim potentiometer is used, connect a 10 k $\Omega$  10-turn potentiometer to terminals 26 (CW), 27 (wiper), and 28 (CCW). Use 0.5 mm<sup>2</sup> (20 AWG) or larger shielded wire, and connect the shield to terminal 21. Do not connect the potentiometer end of the shield. The potentiometer is used to move the speed setting when manually synchronizing the generator or to change load demand in droop mode. If no potentiometer is used, add a 10 k $\Omega$  resistor between terminals 26 and 28.

### **IMPORTANT**

Shielded output lines should be limited to 30 m (98 ft) maximum length.

## Chapter 3. Setup and Calibration

### Introduction

Use this calibration procedure after a Load Sharing Module is installed on a generator set, to obtain the needed operating characteristics during load sharing.

1. Check that the proper voltage is connected to terminals 15(+) and 16(-). Proper polarity must be maintained. See the plant wiring diagram, Figure 1-3.
2. Remove wires from load sharing line terminals 10 and 11, and from the SPM-A Synchronizer (if used) at terminals 24 and 25.
3. Select isochronous operation by shorting terminals 13 and 14.
4. If a speed setting potentiometer is used, set it to mid position (50%).



#### **WARNING**

Be prepared to make an emergency shutdown when starting the engine, turbine, or other type of prime mover, to protect against runaway or overspeed with possible personal injury, loss of life, or property damage.

5. Start the engine according to the engine manufacturer's instructions. Adjust the engine for rated speed. Apply full load to the generator set.

#### **IMPORTANT**

The most accurate calibration is made at full load. However, if it is not possible to run the generator set at full load, run it at less than full load, and reduce the voltage readings given in this calibration procedure proportionally. For example: run a 200 kW generator set at 100 kW and divide all voltages given in this calibration procedure by 2. If you reduce the load in this manner, be sure to reduce it by the same amount throughout the calibration procedure.

6. Set the LOAD GAIN potentiometer fully clockwise.
7. Check the load signal voltage between terminals 22 and 23. Adjust the LOAD GAIN potentiometer for 6.0 Vdc signal. If this voltage is not obtainable, set the load signal as close as possible to 6 Vdc.
8. Remove the load from the generator set.
9. Check the voltage between terminals 22 and 23. This voltage should be 0.0  $\pm$  0.25 Vdc. If this voltage is not correct, the Load Sharing Module unit is faulty or there may still be load on the generator.



## Phasing Check

### **WARNING**

**HIGH VOLTAGE**—A high voltage across open CTs (current transformers) can cause death or serious injury. Do not disconnect a CT from the Load Sharing Module while the engine is running. The CTs can develop dangerously high voltages and may explode if open circuited while the engine is running.

For this check, the generator set must be running isochronously, not paralleled, and with a power factor greater than 0.8.

10. Check that the potential connections are made as follows and correct them if they are not.
  - Phase A to terminal 1
  - Phase B to Terminal 2
  - Phase C to Terminal 3

### **IMPORTANT**

The most accurate calibration is made at full load. However, if it is not possible to run the generator set at full load, run it at less than full load, and reduce the voltage readings given in this calibration procedure proportionally. For example: run a 200 kW generator set at 100 kW and divide all voltages given in this calibration procedure by 2. If you reduce the load in this manner, be sure to reduce it the same amount throughout this calibration procedure.

11. Start the engine and apply full load to the generator set.
12. Using a dc voltmeter, measure the load signal at terminals 22 and 23. Adjust the load gain potentiometer to give a 6 Vdc load signal. If 6 Vdc is not obtainable, set the load signal as close as possible to 6 Vdc. Record this voltage.
13. Shut down the generator set.

### **WARNING**

**HIGH VOLTAGE**—A high voltage across open CTs (current transformers) can cause death or serious injury. Do not disconnect a CT from the Load Sharing Module while the engine is running. The CTs can develop dangerously high voltages and may explode if open circuited while the engine is running.

14. Disconnect the wire from terminal 5 that comes from the phase “A” CT and connect both wires from this CT to terminal 4.
15. Start the generator set and apply full load.
16. Measure the load signal at terminals 22 and 23. If the phase “B” and “C” current transformers are connected correctly, this voltage will be 1/3 lower than the voltage recorded in step 13. For example: if the reading was 6 volts in step 13, the reading in this step should be approximately 4 volts.
17. Shut down the generator set.
18. Reconnect the phase “A” CT wire to terminal 5.
19. If the reading in step 16 was correct, proceed to Load Gain Adjustment later in this chapter. Otherwise, perform the following Phase Correction Procedure.

## Phase Correction Procedure

If this procedure is followed, the correct connection of the current transformers is assured; the correct CT will be connected to the correct input on the Load Sharing Module with the correct polarity. Use this procedure only if the Phasing Check indicates that the phasing is incorrect.

A CT for any phase (A, B, or C), will produce the most positive load signal voltage when it is connected, in the proper polarity, to the terminals on the Load Sharing Module which correspond to the same phase. Any other connections of this CT will produce a less positive load signal voltage. This procedure makes trial connections of the first CT to all three CT inputs on the Load Sharing Module, polarized both ways on each CT input. The load signal voltage is recorded for each connection, and the CT is then connected to the CT input terminals that produced the most positive load signal voltage and with the polarity that produced the most positive load signal voltage.

In a like manner, the second CT is tried on each of the two remaining CT input terminals in each polarity, then connected, in the correct polarity, to the terminals which produced the most positive load signal voltage.

The remaining CT is then connected to the remaining CT input and the load signal checked for each polarity. This CT is then connected to the CT input, polarized so that it produces the most positive load signal voltage.

When the procedure is completed, all three CTs are connected to the proper CT inputs on the Load Sharing Module, with the correct polarity, and are now labeled with their correct designations.

The procedure for correcting phase wiring requires that the generator set be shut down and the current transformers disconnected many times. For convenience during the phasing check, the temporary method of connecting the current transformers shown in Figure 3-1 is recommended. By connecting a burden resistor (a 0.5  $\Omega$ , 20 W resistor), across each current transformer, that current transformer can be disconnected from the Load Sharing Module after removing all load. The connections between the terminal strip and the Load Sharing Module can be changed with the generator set running; however, remove all load before any changes in connections are made. *Do not disconnect a wire from a current transformer with load on the system.* After completion of the procedure remove the terminal strip and the resistors.



**WARNING** HIGH VOLTAGE—A high voltage across open CTs (current transformers) can cause death or serious injury. Do not disconnect a CT from the Load Sharing Module while the engine is running. The CTs can develop dangerously high voltages and may explode if open circuited while the engine is running.

For this procedure, the generator set must be running isochronously, not paralleled, and with a power factor greater than 0.8.

1. Start with the generator shut down.
2. Label each CT wire with the phase and polarity that you think it should be. Even though this identification may prove to be wrong during this procedure, this step is necessary so that the individual wires may be identified during the description of the procedure.

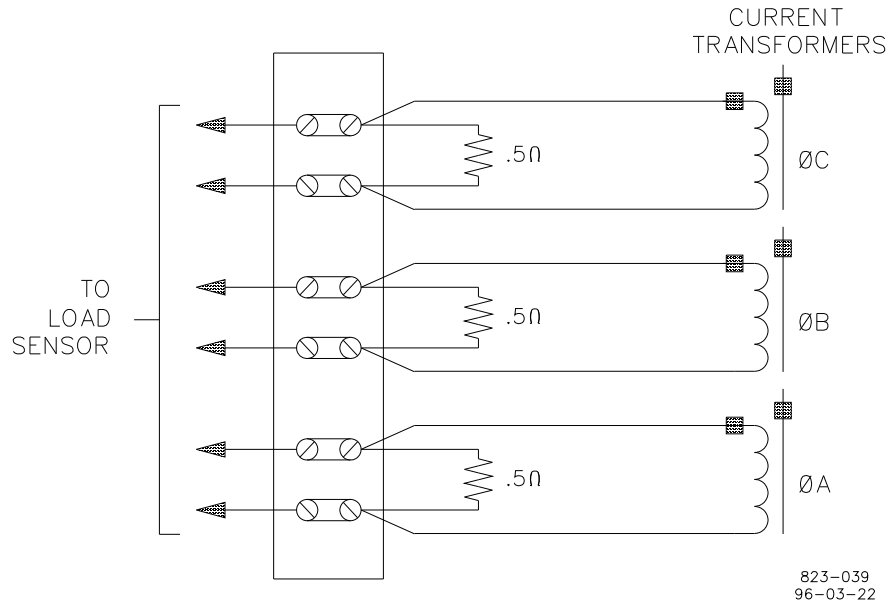

Figure 3-1. Temporary CT Connections

3. Disconnect the phase "B" CT wires from terminals 6 and 7 and connect these two wires together. Use a small screw and nut and tape the connection.
4. Disconnect the phase "C" CT wires from terminals 8 and 9 and connect these two wires together. Use a small screw and nut and tape the connection.
5. Connect the two wires from the phase "A" CT to phase "A" input terminals 4 and 5.



**WARNING** Be prepared to make an emergency shutdown when starting the engine, turbine, or other type of prime mover, to protect against runaway or overspeed with possible personal injury, loss of life, or property damage.

6. Start the engine and apply full load.
7. Measure the load signal voltage between terminals 22 and 23 and record this voltage.
8. Shut the generator set down and reverse the phase "A" wires on terminals 4 and 5.
9. Start the engine and apply full load.
10. Measure the load signal voltage between terminals 22 and 23 and record this voltage.
11. Shut the generator set down.
12. Remove the phase "A" CT wires from terminal 4 and 5 and connect the phase "A" CT wires to the phase "B" input terminals 6 and 7.

13. Start the engine and apply full load.
14. Measure the load signal voltage between terminals 22 and 23 and record this voltage.
15. Shut the generator set down and reverse the phase "A" CT wires on terminals 6 and 7.
16. Start the engine and apply full load.
17. Measure the load signal voltage between terminals 22 and 23 and record this voltage.
18. Shut down the generator set.
19. Remove the phase "A" CT wires from terminal 6 and 7 and connect the phase "A" CT wires to the phase "C" input terminals 8 and 9.
20. Start the engine and apply full load.
21. Measure the load signal voltage between terminals 22 and 23 and record this voltage.
22. Shut the generator set down and reverse the phase "A" wires on terminals 8 and 9.
23. Start the engine and apply full load.
24. Measure the load signal voltage between terminals 22 and 23 and record this voltage.
25. Shut down the generator set.
26. Remove the phase "A" CT wires from terminal 8 and 9 and connect the wires to the pair of terminals, in the same polarity, that produced the most positive load signal voltage.
27. Untape and disconnect the Phase "B" CT wires. Connect the phase "B" CT wires to one pair of the two remaining CT input terminals on the Load Sharing Module.
28. Start the generator set and apply full load.
29. Measure the load signal voltage at terminals 22 and 23 and record this voltage.
30. Shut the generator set down and reverse the phase "B" wires on the CT input terminals.
31. Start the engine and apply full load.
32. Measure the load signal voltage between terminals 22 and 23 and record this voltage.
33. Shut down the generator set.
34. Remove the phase "B" CT wires from the terminals they are connected to and connect them to the remaining pair of CT input terminals on the Load Sharing Module.

35. Start the generator set and apply full load.
36. Measure the load signal at terminals 22 and 23 and record this voltage.
37. Shut the generator set down and reverse the phase "B" wires on the CT input terminals.
38. Start the engine and apply full load.
39. Measure the load signal voltage between terminals 22 and 23 and record this voltage.
40. Shut down the generator set.
41. Remove the phase "B" CT wires from the CT input terminals and connect the wires to the pair of terminals, in the same polarity, that produced the most positive load signal voltage.
42. Untape and disconnect the Phase "C" CT wires. Connect the phase "C" CT wires to remaining pair of CT input terminals on the Load Sharing Module.
43. Start the generator set and apply full load.
44. Measure the load signal voltage at terminals 22 and 23 and record this voltage.
45. Shut the generator set down and reverse the phase "C" wires on the CT input terminals.
46. Start the engine and apply full load.
47. Measure the load signal voltage between terminals 22 and 23 and record this voltage.
48. Shut down the generator set.
49. Remove the phase "C" CT wires from the CT input terminals and connect the wires to the pair of terminals, in the same polarity that produced the most positive load signal voltage.
50. Label each wire with the designation of the terminal to which it is now connected. Be sure and remove the original designations to avoid future confusion.

## Load Gain Adjustment

For this procedure, the generator set must be running isochronously, not paralleled, and with a power factor greater than 0.8.

1. Start the generator set and run at full load.
2. Measure the load signal voltage and adjust the LOAD GAIN potentiometer for  $6 \pm 0.1$  Vdc.

If the load signal voltage cannot be raised to 6 volts, and the phasing has been checked and is correct, it will be necessary to use a lower load signal voltage. Set the full load signal voltages of all generator sets in the system to the same voltage.

When paralleled, adjustment of a generator set's LOAD GAIN potentiometer clockwise will cause that generator set to carry less load. If stability problems occur when paralleled at a particular load signal voltage, reduce the load signal voltage by adjusting the LOAD GAIN potentiometer counterclockwise and set the load signal voltage of all other generator sets in the system to the same voltage (NOTE—Adjust the LOAD GAIN with the generator running isochronously and not paralleled). When the load signal voltages of all generator sets in a system are reduced, the load sharing gain will be reduced. This may result in some loss of load-sharing sensitivity but will increase load sharing stability. It may be necessary to reduce the load signal voltage of each unit in the system to as low as three volts in cases of extremely poor system dynamics.

## Droop Adjustment

Droop is usually expressed as a percentage. Droop percentage is calculated by dividing the difference between the no load speed and the full load speed by the rated speed.

The DROOP potentiometer only needs to be adjusted when the generator set is to be operated in droop mode. The method of setting droop depends on whether the load on the generator set is an isolated load or an infinite bus. Once adjusted, the droop potentiometer will not have to be readjusted unless a different droop percentage is desired.

### Setting Droop for an Isolated Load

1. Open the OPEN FOR DROOP switch (or disconnect the wires from terminals 13 and 14).
2. Start the engine and adjust the speed for rated with no load.
3. Apply full load.
4. Adjust the DROOP potentiometer to give the desired speed.  
Example: Operating at 60 Hz, 57 Hz at full load indicates 5 percent droop. If only 50 percent loading is possible, 58.5 Hz would indicate 5 percent droop (see Figure 3-2).

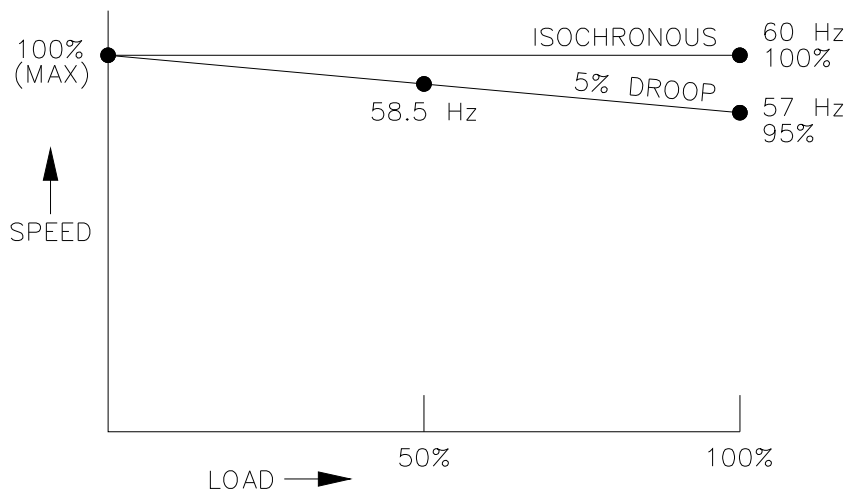

823-038

Figure 3-2. Droop Adjustment

## Setting Droop for an Infinite Bus

1. With the generator not paralleled, adjust the speed above rated frequency by the percent droop required (set engine at 63 Hz for 5 percent droop on a 60 Hz system).
2. Mark the speed setting potentiometer position or measure dc voltage on TB27(+) and TB26(-), and re-adjust the engine speed for rated frequency.
3. Turn the DROOP potentiometer fully clockwise for maximum droop.
4. Synchronize the generator with the bus and parallel it with the bus.
5. Increase the speed setting potentiometer to the position marked in step 2, increasing load.
6. Slowly adjust the DROOP potentiometer counterclockwise, decreasing droop, until 100 percent load is obtained.

If it is necessary to set the droop without pulling 100 percent load, set the engine speed accordingly for the desired percent of droop at the load to be pulled. For example: Five percent droop at 50 percent load will require a no load rated speed of 61.5 Hz, not 63 Hz, on a 60 Hz system.

## Chapter 4.

# Theory of Operation

### Introduction

This chapter describes the operation of the Load Sharing Module and its internal circuits. Figure 1-4 is a block diagram of the circuits in the module.

The Load Sharing Module senses the power output of a generator and provides a pulse-width modulated signal to the Caterpillar digital speed control to adjust the power output of the engine-generator set to match the reference power level. The Load Sharing Module can also produce a droop condition (instead of isochronous load-sharing) for the engine with Caterpillar digital speed control, making it possible to connect the generator set in parallel with either a generator set which is running isochronously, or with an infinite bus.

### Power Supply

The internal power supply generates a regulated dc voltage for the operation of the circuits in the Load Sharing Module. The power supply gets its power from the engine 24 Vdc power source. To prevent damage to the Load Sharing Module that uses an alternator or battery charging device, make sure the charging device is turned off before disconnecting or connecting the 24 Vdc supply to the unit.

### Power Sensor

Generator load is measured by the power-sensor circuit of the Load Sharing Module. The power-sensor circuit senses current amplitude, and produces a load signal proportional to the current amplitude times the power factor. The potential input comes from potential transformers (PTs) and the current input comes from the current transformers (CTs). The circuit uses these two inputs to generate a load signal which is then filtered and sent to the controller circuit. The load signal voltage of each generator set will be proportional to the percentage of rated load on the generator set.

Ammeters and voltmeters may be driven with the same PT and CT wires.

### Load Comparator Circuit

In the load comparator circuit, the load signal voltage is balanced with the other generator sets in the system via the load sharing lines. The comparator circuit of each Load Sharing Module includes a load gain potentiometer to adjust each generator set's load signal so that the load signal voltage of each is the same at full load. This compensates for varying CT ratios or different generator set sizes. The load sharing voltage will be one-half the measured voltage of the load signal test point.



## Speed Trim Circuit

A 10 k $\Omega$ , 10-turn speed-trim potentiometer can be added to the Load Sharing Module to permit remote adjustment of the load or frequency of the generator. The speed trim is normally used for manual synchronization of a generator set with an existing bus or to change the load demand when in droop mode. If no speed trim is needed, add a 10 k $\Omega$  resistor between terminals 26 and 28.

## Isochronous Load Sharing

Each comparator circuit compares the load signal voltage for its generator set to two times the voltage on the load sharing lines and produces an error voltage proportional to the difference. This error voltage is used to generate a pulse width modulated signal which is output to the Caterpillar speed control. This output biases the speed loop of the Caterpillar control until the load signal voltage is equal to that of other generators on the load sharing lines.

## Droop Operation

In droop operation, a portion of the load signal voltage is fed to the controller circuit. This voltage is used by the comparator circuit to reduce the control output by a percentage determined by the DROOP potentiometer. The output is reduced, and the Caterpillar digital speed control reduces engine power according to the desired droop percentage.

When a generator set using the Load Sharing Module is paralleled in droop with other generator sets, the common load signal on the paralleling lines is not used. The frequency of the generator set will therefore vary with load, so it must be determined by a different means. In an isolated system with two or more generator sets paralleled, if isochronous speed control is required, one of the generator sets must be running in the isochronous (constant speed) mode. This generator set maintains the frequency of the system. If a generator set is in droop and is paralleled with an infinite bus, the bus determines and maintains the frequency. The DROOP percentage and the speed setting on the Caterpillar digital speed control determine the amount of the load that is carried by the generator, when running in droop.

## Auxiliary Equipment

The Woodward SPM-A synchronizer functions by biasing the output of the Load Sharing Module. All other Woodward auxiliary generating control equipment functions by biasing the voltage on the load-sharing lines.

## Pulse Width Modulation

The Load Sharing Module output to the Caterpillar digital speed control engine is a frequency of  $500 \pm 100$  Hz. The duty cycle ranges from a low of 10 percent for maximum decrease in load or speed to a high of 90 percent for maximum increase in speed or load. The duty cycle varies according to the magnitude of difference between the reference load and the actual power generation.

# Chapter 5. Troubleshooting

The following trouble-shooting guide is an aid in isolating trouble to the Load Sharing Module, engine control, plant wiring, or elsewhere. The guide assumes that the system wiring, soldered connections, switch and relay contacts, and input and output connections are correct and in good working order. Make the checks in the order indicated.

NOTICE	<p><b>To prevent possible serious damage to the Load Sharing Module, do not attempt to service the unit beyond that described in the operating instructions. All other servicing should be referred to qualified service personnel.</b></p>
--------	---

SYMPTOMS	CAUSE	TEST/REMEDY
Undesirable speed decrease with load increase.	Droop mode switch is open or auxiliary contact is open. Load Sharing Module is in droop mode.	Jumper Load Sharing Module terminals 13 and 14. If this corrects the problem, replace wiring or switch as required. The module will not go into droop with the terminals connected.
	Improper engine operation. Operate the engine and observe speed while applying load.	If droop occurs near the full load point only, it is possible the engine is not producing the horsepower called for or is being overloaded.
	Faulty engine control. Disconnect the Load Sharing Module and load the engine as a single, isolated unit.	If speed continues to decrease with load, engine operation may be faulty.
Erratic Load Sharing Module operation.	Open or intermittent wire.	Check all wiring for continuity and tight connections. Repair if necessary.
	EMI (Electromagnetic Interference).	Remove ground loops. Shield all wiring (load sharing lines, output to the speed control, speed trim pot, and SPM-A synchronizer input. Route wiring away from noise sources.
	Unstable system.	Check system for proper operation.
	Unstable voltage regulator.	Consult voltage regulator manufacturer's manual for proper adjustment.
	Poor system stability.	Reduce the load signal voltage of each unit in the system to three volts.
Load Signal voltage is low. Adjusting LOAD Gain won't raise it.	Incorrect phasing of CT and PT wiring.	Perform phasing check. If phasing check indicates need, perform procedure for correct phase wiring.
	Insufficient CT output.	Check for 5 amp CT output at full load. Change to a lower primary current CT if necessary.

SYMPTOMS	CAUSE	TEST/REMEDY
Load Signal voltage is too high. Adjusting LOAD GAIN will not lower it.	CT output too high.	Check for 5 amp CT output at full load. (CT output must be between 3 and 7 amps at full load.) Change to a higher primary current CT if necessary.
Engine does not properly share load with other units.	Engine not responding to signal from Load Sharing Module.	Check for maximum voltage from terminals 22 to 23. If possible check the voltage from terminal 19 to 20. If the Load Sharing Module is putting out a maximum signal, the problem is either in the wiring to the engine control, the engine control, or the engine.
	Unequal speed settings.	Be sure the speed settings of all off-line units at no load are identical. Adjust as necessary. Resynchronize.
	Unequal load gain voltages.	Check that load gain settings of all load sharing units are correct. See load gain adjustment in Chapter 3. Adjust as necessary.
	Improper load sensing phasing.	Perform the transformer phasing check in Chapter 3. Correct as necessary.
Engine does not properly share load with other units.	Circulating currents between generators. (Noted by unequal power factors between generators.)	Properly adjust the generator voltage regulators.
Engine does not properly share load with other units.	Terminals 13 and 14 not shorted. Load sharing module is in droop.	Jumper Load Sharing Module terminals 13 and 14. Observe engine operation. Replace wiring or switch as required.

# Chapter 6.

## Service Options

### Product Service Options

If you are experiencing problems with the installation, or unsatisfactory performance of a Woodward product, the following options are available:

- Consult the troubleshooting guide in the manual.
- Contact the manufacturer or packager of your system.
- Contact the Woodward Full Service Distributor serving your area.
- Contact Woodward technical assistance (see “How to Contact Woodward” later in this chapter) and discuss your problem. In many cases, your problem can be resolved over the phone. If not, you can select which course of action to pursue based on the available services listed in this chapter.

**OEM and Packager Support:** Many Woodward controls and control devices are installed into the equipment system and programmed by an Original Equipment Manufacturer (OEM) or Equipment Packager at their factory. In some cases, the programming is password-protected by the OEM or packager, and they are the best source for product service and support. Warranty service for Woodward products shipped with an equipment system should also be handled through the OEM or Packager. Please review your equipment system documentation for details.

**Woodward Business Partner Support:** Woodward works with and supports a global network of independent business partners whose mission is to serve the users of Woodward controls, as described here:

- A **Full Service Distributor** has the primary responsibility for sales, service, system integration solutions, technical desk support, and aftermarket marketing of standard Woodward products within a specific geographic area and market segment.
- An **Authorized Independent Service Facility (AISF)** provides authorized service that includes repairs, repair parts, and warranty service on Woodward's behalf. Service (not new unit sales) is an AISF's primary mission.
- A **Recognized Engine Retrofitter (RER)** is an independent company that does retrofits and upgrades on reciprocating gas engines and dual-fuel conversions, and can provide the full line of Woodward systems and components for the retrofits and overhauls, emission compliance upgrades, long term service contracts, emergency repairs, etc.
- A **Recognized Turbine Retrofitter (RTR)** is an independent company that does both steam and gas turbine control retrofits and upgrades globally, and can provide the full line of Woodward systems and components for the retrofits and overhauls, long term service contracts, emergency repairs, etc.

You can locate your nearest Woodward distributor, AISF, RER, or RTR on our website at:

[www.woodward.com/directory](http://www.woodward.com/directory)

## Woodward Factory Servicing Options

The following factory options for servicing Woodward products are available through your local Full-Service Distributor or the OEM or Packager of the equipment system, based on the standard Woodward Product and Service Warranty (5-01-1205) that is in effect at the time the product is originally shipped from Woodward or a service is performed:

- Replacement/Exchange (24-hour service)
- Flat Rate Repair
- Flat Rate Remanufacture

**Replacement/Exchange:** Replacement/Exchange is a premium program designed for the user who is in need of immediate service. It allows you to request and receive a like-new replacement unit in minimum time (usually within 24 hours of the request), providing a suitable unit is available at the time of the request, thereby minimizing costly downtime. This is a flat-rate program and includes the full standard Woodward product warranty (Woodward Product and Service Warranty 5-01-1205).

This option allows you to call your Full-Service Distributor in the event of an unexpected outage, or in advance of a scheduled outage, to request a replacement control unit. If the unit is available at the time of the call, it can usually be shipped out within 24 hours. You replace your field control unit with the like-new replacement and return the field unit to the Full-Service Distributor.

Charges for the Replacement/Exchange service are based on a flat rate plus shipping expenses. You are invoiced the flat rate replacement/exchange charge plus a core charge at the time the replacement unit is shipped. If the core (field unit) is returned within 60 days, a credit for the core charge will be issued.

**Flat Rate Repair:** Flat Rate Repair is available for the majority of standard products in the field. This program offers you repair service for your products with the advantage of knowing in advance what the cost will be. All repair work carries the standard Woodward service warranty (Woodward Product and Service Warranty 5-01-1205) on replaced parts and labor.

**Flat Rate Remanufacture:** Flat Rate Remanufacture is very similar to the Flat Rate Repair option with the exception that the unit will be returned to you in “like-new” condition and carry with it the full standard Woodward product warranty (Woodward Product and Service Warranty 5-01-1205). This option is applicable to mechanical products only.

## Returning Equipment for Repair

If a control (or any part of an electronic control) is to be returned for repair, please contact your Full-Service Distributor in advance to obtain Return Authorization and shipping instructions.

When shipping the item(s), attach a tag with the following information:

- return authorization number;
- name and location where the control is installed;
- name and phone number of contact person;
- complete Woodward part number(s) and serial number(s);
- description of the problem;
- instructions describing the desired type of repair.

## Packing a Control

Use the following materials when returning a complete control:

- protective caps on any connectors;
- antistatic protective bags on all electronic modules;
- packing materials that will not damage the surface of the unit;
- at least 100 mm (4 inches) of tightly packed, industry-approved packing material;
- a packing carton with double walls;
- a strong tape around the outside of the carton for increased strength.

### NOTICE

To prevent damage to electronic components caused by improper handling, read and observe the precautions in Woodward manual 82715, *Guide for Handling and Protection of Electronic Controls, Printed Circuit Boards, and Modules*.

## Replacement Parts

When ordering replacement parts for controls, include the following information:

- the part number(s) (XXXX-XXXX) that is on the enclosure nameplate;
- the unit serial number, which is also on the nameplate.

## Engineering Services

Woodward offers various Engineering Services for our products. For these services, you can contact us by telephone, by email, or through the Woodward website.

- Technical Support
- Product Training
- Field Service

**Technical Support** is available from your equipment system supplier, your local Full-Service Distributor, or from many of Woodward's worldwide locations, depending upon the product and application. This service can assist you with technical questions or problem solving during the normal business hours of the Woodward location you contact. Emergency assistance is also available during non-business hours by phoning Woodward and stating the urgency of your problem.

**Product Training** is available as standard classes at many of our worldwide locations. We also offer customized classes, which can be tailored to your needs and can be held at one of our locations or at your site. This training, conducted by experienced personnel, will assure that you will be able to maintain system reliability and availability.

**Field Service** engineering on-site support is available, depending on the product and location, from many of our worldwide locations or from one of our Full-Service Distributors. The field engineers are experienced both on Woodward products as well as on much of the non-Woodward equipment with which our products interface.

For information on these services, please contact us via telephone, email us, or use our website: [www.woodward.com](http://www.woodward.com).

## How to Contact Woodward

For assistance, call one of the following Woodward facilities to obtain the address and phone number of the facility nearest your location where you will be able to get information and service.

### Electrical Power Systems

<u>Facility</u>	<u>Phone Number</u>
Brazil	+55 (19) 3708 4800
China	+86 (512) 6762 6727
Germany	+49 (0) 21 52 14 51
India	+91 (129) 4097100
Japan	+81 (43) 213-2191
Korea	+82 (51) 636-7080
Poland	+48 12 295 13 00
United States	+1 (970) 482-5811

### Engine Systems

<u>Facility</u>	<u>Phone Number</u>
Brazil	+55 (19) 3708 4800
China	+86 (512) 6762 6727
Germany	+49 (711) 78954-510
India	+91 (129) 4097100
Japan	+81 (43) 213-2191
Korea	+82 (51) 636-7080
The Netherlands	+31 (23) 5661111
United States	+1 (970) 482-5811

### Turbine Systems

<u>Facility</u>	<u>Phone Number</u>
Brazil	+55 (19) 3708 4800
China	+86 (512) 6762 6727
India	+91 (129) 4097100
Japan	+81 (43) 213-2191
Korea	+82 (51) 636-7080
The Netherlands	+31 (23) 5661111
Poland	+48 12 295 13 00
United States	+1 (970) 482-5811

You can also locate your nearest Woodward distributor or service facility on our website at:

[www.woodward.com/directory](http://www.woodward.com/directory)

## Technical Assistance

If you need to telephone for technical assistance, you will need to provide the following information. Please write it down here before phoning:

Your Name	_____
Site Location	_____
Phone Number	_____
Fax Number	_____
<hr/>	
Engine/Turbine Model Number	_____
Manufacturer	_____
Number of Cylinders (if applicable)	_____
Type of Fuel (gas, gaseous, steam, etc)	_____
Rating	_____
Application	_____
<hr/>	
<b>Control/Governor #1</b>	
Woodward Part Number & Rev. Letter	_____
Control Description or Governor Type	_____
Serial Number	_____
<hr/>	
<b>Control/Governor #2</b>	
Woodward Part Number & Rev. Letter	_____
Control Description or Governor Type	_____
Serial Number	_____
<hr/>	
<b>Control/Governor #3</b>	
Woodward Part Number & Rev. Letter	_____
Control Description or Governor Type	_____
Serial Number	_____

*If you have an electronic or programmable control, please have the adjustment setting positions or the menu settings written down and with you at the time of the call.*

## Appendix.

# LSM Control Specifications

<b>POWER SUPPLY</b>	18–32 Vdc, approximately 5 W. Protected against undervoltage, overvoltage to +80 Vdc, reverse voltage to –32 Vdc.
<b>INPUTS</b>	
3-phase PT Inputs	100–240 Vac line-to-line, 50–400 Hz. PT input burden is between 1.5 VA and 1.7 VA per phase at 240 Vac, and between 0.4 VA and 0.5 VA per phase at 120 Vac.
3-phase CT Inputs	3–7 Arms at full load, CT input burden at full load is 0.1 VA per phase.
Load Sharing Input	0–3 Vdc into 25 k $\Omega$ impedance in isochronous mode, open circuit in droop mode.
Sync Input	Compatible with optional Woodward SPM-A Synchronizer, 0.38% speed change* per volt input.
Speed Trim	$\pm 10\%$ minimum speed change* with an external 10 k $\Omega$ potentiometer.
Droop Switch	The external droop switch is to be wired in series with the auxiliary circuit breaker contact between terminals 13 and 14. Droop mode is selected when either the droop switch or the auxiliary circuit breaker is open.
<b>OUTPUTS</b>	
Load Signal	DC signal proportional to total real current measured by the Load Sharing Module. Load Gain adjustable over minimum range of 0.86 to 2.0 Vdc/Arms.
PWM Output	Pulse width modulated square wave, 500 $\pm$ 100 Hz. Zero error output duty cycle = 69.8 $\pm$ 2.0%. Minimum V(hi) = 10.0 Vdc, maximum V(lo) = 0.5 Vdc when driving external 5.1K load to 13.0 Vdc external pull-up.
<b>ADJUSTMENTS</b>	
Droop	Provides 0 to 9% speed reduction* between no load and full load conditions.
Load Gain	Provides adjustment of the load on an individual generator when two or more generators are paralleled. Adjusts specified full load condition from 3 to 7 Arms.



**ENVIRONMENTAL**

Operating Temperature	–40 to +70 °C (–40 to +158 °F).
Salt Fog	Tested at 5% NaCl, 35 °C, 48 hrs wet, 48 hrs dry.
Humidity	Tested at 95% RH, 65 °C, non-condensing, 5 cycles at 24 hr/cycle.
Vibration	Swept sine: 4 G, 5 mm, 5–2000 Hz, 3 hr min/axis, including four 30-minute dwells at resonant frequencies.
Shock	40 G, 11 ms sawtooth pulse.
Installation Overvoltage Category	Category III.
Air Quality	Pollution Degree 2.

**DIMENSIONS**

Linear (maximum)	Length: 273.6 mm (10.77 in) Width: 214.1 mm (8.43 in) Height: 59.2 mm (2.33 in)
Weight	1397 g (49.3 oz) approximate

**SAFETY AND EMC STANDARDS COMPLIANCE**

Conforms to EMC Directive 89/336/EEC. Conformity established by testing.

Conforms to Low Voltage Directive 73/23/EEC when used in accordance with instructions. Conformity established by testing.

Listed to UL and cUL Industrial Control Equipment (UL508).

**\*—When used with a speed control having a gain of 0.382% speed change per 1% duty cycle change.**

---

## Revision History

---

### Changes in Revision G—

- Updated Figures 1-2 and 1-3 to show improved grounding connection
- Added note (page 6) to explain improved grounding connection

# Declarations

## DECLARATION OF CONFORMITY

According to EN 45014

**Manufacturer's Name:** WOODWARD GOVERNOR COMPANY (WGC)  
Industrial Controls Group

**Manufacturer's Address:** 1000 E. Drake Rd.  
Fort Collins, CO, USA, 80525

**Model Name(s)/Number(s):** Load Sharing Module - 115/230 VAC, Analog Output/9907-173;  
115/230 VAC, PWM Output/9907-174; 24 VDC, PWM Output/9907-175; 24 VDC Analog Output/9907-252.

**Conformance to Directive(s):** 89/336/EEC COUNCIL DIRECTIVE of 03 May 1989 on the  
approximation of the laws of the Member States relating to  
electromagnetic compatibility

73/23/EEC COUNCIL DIRECTIVE of 19 February 1973 on the  
harmonization of the laws of the Member States relating to electrical  
equipment designed for use within certain voltage limits

**Applicable Standards:** EN61000-6-2, 2001: EMC Part 6-2: Generic Standards - Immunity  
for Industrial Environments  
EN61000-6-4, 2001: EMC Part 6-4: Generic Standards - Emissions  
for Industrial Environments

EN50178, 1997: Electronic Equipment for Use in Power Installations

**We, the undersigned, hereby declare that the equipment specified above conforms to the above Directive(s).**

**MANUFACTURER**

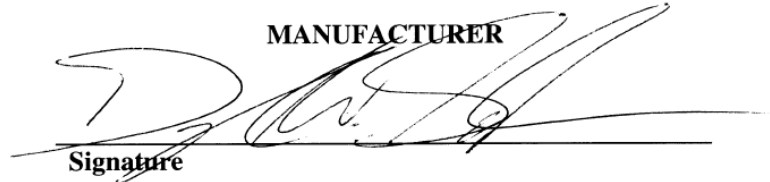

**Signature**

Douglas W. Salter

**Full Name**

Engineering Manager

**Position**

WIC, Fort Collins, CO, USA

**Place**

03-01-31

**Date**

We appreciate your comments about the content of our publications.

Send comments to: [icinfo@woodward.com](mailto:icinfo@woodward.com)

Please reference publication **02036G**.



B02036:G



PO Box 1519, Fort Collins CO 80522-1519, USA  
1000 East Drake Road, Fort Collins CO 80525, USA  
Phone +1 (970) 482-5811 • Fax +1 (970) 498-3058

Email and Website—[www.woodward.com](http://www.woodward.com)

Woodward has company-owned plants, subsidiaries, and branches,  
as well as authorized distributors and other authorized service and sales facilities throughout the world.

Complete address / phone / fax / email information for all locations is available on our website.