



*Allen-Bradley*

# **1394 SERCOS Interface Multi-Axis Motion Control System**

(Catalog Numbers  
1394C-SJT05-D,  
1394C-SJT10-D,  
1394C-SJT22-D)

**Integration Manual**

**Rockwell  
Automation**

## Important User Information

Because of the variety of uses for the products described in this publication, those responsible for the application and use of this control equipment must satisfy themselves that all necessary steps have been taken to assure that each application and use meets all performance and safety requirements, including any applicable laws, regulations, codes and standards.

The illustrations, charts, sample programs and layout examples shown in this guide are intended solely for purposes of example. Since there are many variables and requirements associated with any particular installation, Allen-Bradley® does not assume responsibility or liability (to include intellectual property liability) for actual use based upon the examples shown in this publication.

Allen-Bradley publication SGI-1.1, *Safety Guidelines for the Application, Installation and Maintenance of Solid-State Control* (available from your local Allen-Bradley office), describes some important differences between solid-state equipment and electromechanical devices that should be taken into consideration when applying products such as those described in this publication.

Reproduction of the contents of this copyrighted publication, in whole or part, without written permission of Rockwell Automation, is prohibited.

Throughout this manual we use notes to make you aware of safety considerations:

---

### ATTENTION



Identifies information about practices or circumstances that can lead to personal injury or death, property damage or economic loss.

---

Attention statements help you to:

- identify a hazard
- avoid a hazard
- recognize the consequences

---

### IMPORTANT

Identifies information that is critical for successful application and understanding of the product.

---

<b>Preface</b>	Who Should Use this Manual . . . . .	P-1
	Purpose of this Manual . . . . .	P-1
	Contents of this Manual . . . . .	P-2
	Related Documentation . . . . .	P-2
	Conventions Used in this Manual . . . . .	P-3
	Product Receiving and Storage Responsibility . . . . .	P-3
	Allen-Bradley Support . . . . .	P-4
	Local Product Support . . . . .	P-4
	Technical Product Assistance . . . . .	P-4
	Comments Regarding this Manual . . . . .	P-4
	<b>Chapter 1</b>	
<b>Commissioning Your 1394 SERCOS Interface System</b>	Chapter Objectives. . . . .	1-1
	General Startup Precautions . . . . .	1-2
	Understanding 1394 Connectors . . . . .	1-3
	System Module Connectors . . . . .	1-3
	Axis Module Connectors . . . . .	1-3
	Locating System Module Connectors and Indicators . . . . .	1-4
	Locating Axis Module Connectors and Indicators . . . . .	1-6
	Locating SERCOS Interface Fiber-Optic Connectors . . . . .	1-7
	Configuring Your 1394 SERCOS interface System . . . . .	1-7
	Configuring Your 1394 System Module . . . . .	1-8
	Configuring Your Logix SERCOS interface Module . . . . .	1-11
	Configuring Your Logix Controller. . . . .	1-11
	Configuring Your Logix Module . . . . .	1-13
	Configuring Your 1394 System Module . . . . .	1-15
	Configuring the Motion Group . . . . .	1-17
	Configuring Axis Properties. . . . .	1-18
	Downloading Your Program . . . . .	1-19
	Applying Power to the 1394 SERCOS interface System. . . . .	1-20
	Testing and Tuning Your Axes . . . . .	1-22
	Testing Your Axes . . . . .	1-23
	Tuning Your Axes . . . . .	1-26
	<b>Chapter 2</b>	
<b>Troubleshooting Your 1394 SERCOS Interface System</b>	Chapter Objectives. . . . .	2-1
	Safety Precautions . . . . .	2-2
	Understanding How to Detect a Problem . . . . .	2-2
	Troubleshooting System and Axis Module LEDs . . . . .	2-3
	Troubleshooting the SERCOS Network Status LED. . . . .	2-5
	Troubleshooting System and Axis Module Faults. . . . .	2-6
	System Module Faults . . . . .	2-6
	Axis Module Faults . . . . .	2-9
	Troubleshooting General System Problems . . . . .	2-12
	Understanding Logix/Drive Fault Behavior . . . . .	2-14
	System Module Faults . . . . .	2-14
	Axis Module Faults . . . . .	2-16

Supplemental Troubleshooting Information . . . . .	2-18
Tools for Changing Parameters . . . . .	2-18
Using Analog Test Points to Monitor System Variables . . . . .	2-20
Changing Default Digital Output Settings . . . . .	2-22
Replacing System and Axis Modules . . . . .	2-23
Before You Begin . . . . .	2-23
Removing an Axis Module . . . . .	2-24
Installing a Replacement Axis Module . . . . .	2-25
Removing a System Module . . . . .	2-26
Installing a Replacement System Module . . . . .	2-27

## Appendix A

### Interconnect Diagrams

Chapter Objectives . . . . .	A-1
1394 SERCOS Interface Interconnect Diagram Notes . . . . .	A-2
Power Interconnect Diagrams . . . . .	A-3
Shunt Module Interconnect Diagrams . . . . .	A-4
Axis Module/Motor Interconnect Diagrams . . . . .	A-6
Thermal Switch and Brake Interconnect Diagrams . . . . .	A-9
Understanding Motor Thermal Switches . . . . .	A-9
How Your Feedback Cable Affects Thermal Switch Wiring . . . . .	A-9
Thermal Switch Interconnect Diagrams . . . . .	A-9
Brake Interconnect Diagrams . . . . .	A-14

---

# Preface

Read this preface to familiarize yourself with the rest of the manual. The preface covers the following topics:

- Who Should Use this Manual
- Purpose of this Manual
- Contents of this Manual
- Related Documentation
- Conventions Used in this Manual
- Product Receiving and Storage Responsibility
- Allen-Bradley Support

## Who Should Use this Manual

This manual is intended for engineers or programmers directly involved in the operation, field maintenance, and integration of the 1394 SERCOS interface™ system with the Logix™ SERCOS interface module.

If you do not have a basic understanding of the 1394, contact your local Allen-Bradley representative for information on available training courses before using this product.

## Purpose of this Manual

This manual provides the startup, configuring, and troubleshooting procedures for the 1394 SERCOS interface system. The purpose of this manual is to assist you in the startup of your 1394 and the integration of your 1394 with the ControlLogix™ 1756-MxxSE SERCOS interface module or SoftLogix™ 1784-PM16SE SERCOS interface PCI card.

## Contents of this Manual

Chapter	Title	Contents
	<i>Preface</i>	Describes the purpose, background, and scope of this manual. Also specifies the audience for whom this manual is intended.
1	<i>Commissioning Your 1394 SERCOS Interface System</i>	Provides steps to follow when configuring your 1394 with the Logix SERCOS interface module and describes how to apply power to your 1394 SERCOS interface system for the first time.
2	<i>Troubleshooting Your 1394 SERCOS Interface System</i>	Provides diagnostic aids that help isolate problems with your 1394 SERCOS interface system.
Appendix A	<i>Interconnect Diagrams</i>	Provides interconnect diagrams for the 1394 SERCOS interface system.

## Related Documentation

The following documents contain additional information concerning related Allen-Bradley products. To obtain a copy, contact your local Allen-Bradley office, distributor, or download them from [TheAutomationBookstore.com](http://TheAutomationBookstore.com).

For:	Read This Document:	Publication Number:
The instructions needed for the installation and wiring of the 1394 SERCOS interface system	<i>1394 SERCOS interface Installation Manual</i>	1394-IN002x-EN-P
A description and specifications for the Ultra3000 family including motors and motor accessories	<i>Motion Control Selection Guide</i>	GMC-SG001x-EN-P
Application sizing and configuration information	Motion Book Servo Sizing CD	Motion Book- <i>mmmyy</i>
More detailed information on the use of ControlLogix motion features and application examples	<i>ControlLogix Motion Module Programming Manual</i>	1756-RM086x-EN-P
ControlLogix SERCOS interface module installation instructions	<i>8 or 16 Axis SERCOS interface Module Installation Instructions</i>	1756-IN572x-EN-P
SoftLogix SERCOS interface PCI card installation instructions	<i>16 Axis PCI SERCOS interface Card Installation Instructions</i>	1784-IN041x-EN-P
The instructions needed to program a motion application	<i>Logix Controller Motion Instruction Set Reference Manual</i>	1756-RM007x-EN-P
Information on configuring and troubleshooting your ControlLogix motion module	<i>ControlLogix Motion Module Setup and Configuration Manual</i>	1756-UM006x-EN-P
Information on configuring and troubleshooting your SoftLogix PCI card	<i>SoftLogix Motion Card Setup and Configuration Manual</i>	1784-UM003x-EN-P
Information on proper handling, installing, testing, and troubleshooting fiber-optic cables	<i>Fiber Optic Cable Installation and Handling Instructions</i>	2090-IN010x-EN-P
Information, examples, and techniques designed to minimize system failures caused by electrical noise	<i>System Design for Control of Electrical Noise Reference Manual</i>	GMC-RM001x-EN-P
For declarations of conformity (DoC) currently available from Rockwell Automation	Rockwell Automation Product Certification website	<a href="http://www.ab.com/certification/ce/docs">www.ab.com/certification/ce/docs</a>
An article on wire sizes and types for grounding electrical equipment	<i>National Electrical Code</i>	Published by the National Fire Protection Association of Boston, MA.
A glossary of industrial automation terms and abbreviations	<i>Allen-Bradley Industrial Automation Glossary</i>	AG-7.1

## Conventions Used in this Manual

The following conventions are used throughout this manual:

- Bulleted lists such as this one provide information, not procedural steps.
- Numbered lists provide sequential steps or hierarchical information.
- Words that you type or select appear in bold.
- When we refer you to another location, the section or chapter name appears in italics.

## Product Receiving and Storage Responsibility

You, the customer, are responsible for thoroughly inspecting the equipment before accepting the shipment from the freight company. Check the item(s) you receive against your purchase order. If any items are obviously damaged, it is your responsibility to refuse delivery until the freight agent has noted the damage on the freight bill. Should you discover any concealed damage during unpacking, you are responsible for notifying the freight agent. Leave the shipping container intact and request that the freight agent make a visual inspection of the equipment.

Leave the product in its shipping container prior to installation. If you are not going to use the equipment for a period of time, store it:

- in a clean, dry location
- within an ambient temperature range of 0 to 65° C (32 to 149° F)
- within a relative humidity range of 5% to 95%, non-condensing
- in an area where it cannot be exposed to a corrosive atmosphere
- in a non-construction area

## Allen-Bradley Support

Allen-Bradley offers support services worldwide, with over 75 Sales/Support Offices, 512 authorized Distributors and 260 authorized Systems Integrators located throughout the United States alone, plus Allen-Bradley representatives in every major country in the world.

### Local Product Support

Contact your local Allen-Bradley representative for:

- sales and order support
- product technical training
- warranty support
- support service agreements

### Technical Product Assistance

If you need to contact Allen-Bradley for technical assistance, please review the information in *Chapter 2* first, then call your local Allen-Bradley representative or Rockwell Automation Technical Support at (440)-646-5800. For the quickest possible response, please have the catalog numbers of your products available when you call. For Rockwell Automation Technical Support on the web, go to [www.ab.com/support](http://www.ab.com/support).

### Comments Regarding this Manual

To offer comments regarding the contents of this manual, go to [www.ab.com/manuals/gmc](http://www.ab.com/manuals/gmc) and download the Motion Control Problem Report form. Mail or fax your comments to the address/fax number given on the form.



# Commissioning Your 1394 SERCOS Interface System

## Chapter Objectives

This chapter provides you with the information to set up, configure, and apply power to your 1394 system. This chapter includes:

- General Startup Precautions
- Understanding 1394 Connectors
- Locating System Module Connectors and Indicators
- Locating Axis Module Connectors and Indicators
- Locating SERCOS Interface Fiber-Optic Connectors
- Configuring Your 1394 SERCOS interface System
- Configuring Your Logix SERCOS interface Module
- Applying Power to the 1394 SERCOS interface System
- Testing and Tuning Your Axes

These procedures assume you have completed mounting, wiring, and connecting your 1394 system and Logix SERCOS interface module as described in the *1394 SERCOS Interface Installation Manual* (publication 1394-IN002x-EN-P).

Note: Some of the procedures in this chapter include information regarding integration with other products.

## General Startup Precautions

The following precautions pertain to all of the procedures in this chapter. Be sure to read and thoroughly understand them before proceeding.

---

**ATTENTION**

This product contains stored energy devices. To avoid hazard of electrical shock, verify that all voltages on the system bus network have been discharged before attempting to service, repair or remove this unit. Only qualified personnel familiar with solid state control equipment and safety procedures in publication NFPA 70E or applicable local codes should attempt this procedure.

---

**ATTENTION**

This drive contains ESD (Electrostatic Discharge) sensitive parts and assemblies. You are required to follow static control precautions when you install, test, service, or repair this assembly. If you do not follow ESD control procedures, components can be damaged. If you are not familiar with static control procedures, refer to Allen-Bradley publication 8000-4.5.2, *Guarding Against Electrostatic Damage* or any other applicable ESD Protection Handbook.

---

## Understanding 1394 Connectors

The following tables provide a brief description of the 1394 connectors.

### System Module Connectors

Description	Connector	Present on this 1394 System Module
Input Power	4-position connector housing	1394C-SJT05-D / 1394C-SJT10-D
Logic Power	2-position connector housing	
Shunt Power	3-position connector housing	
Logic, Shunt, and Input Power Terminal Block	8-position terminal block	1394C-SJT22-D
Single Point Bond Bar	5-position grounding bar	1394C-SJT05-D, 1394C-SJT10-D, or 1394C-SJT22-D
Motor/Auxiliary Feedback	13-position connector housing	
Relay Outputs	10-position connector housing	
Analog Outputs	9-position connector housing	
Discrete Input	8-position connector housing (4)	
SERCOS Transmit and Receive	SERCOS fiber-optic (2)	
DPI/SCANport™	DPI/SCANport	

### Axis Module Connectors

Description	Connector
Motor Power Terminal Block	6-position terminal block
Motor Brake/Thermal (TB1/TB2)	4-position connector housing (2)

# Locating System Module Connectors and Indicators

Use the figure below to locate the 1394C-SJT05-D and -SJT10-D System Module connectors and indicators.

**Figure 1.1**  
**1394 System Modules (1394C-SJT05-D and -SJT10-D)**

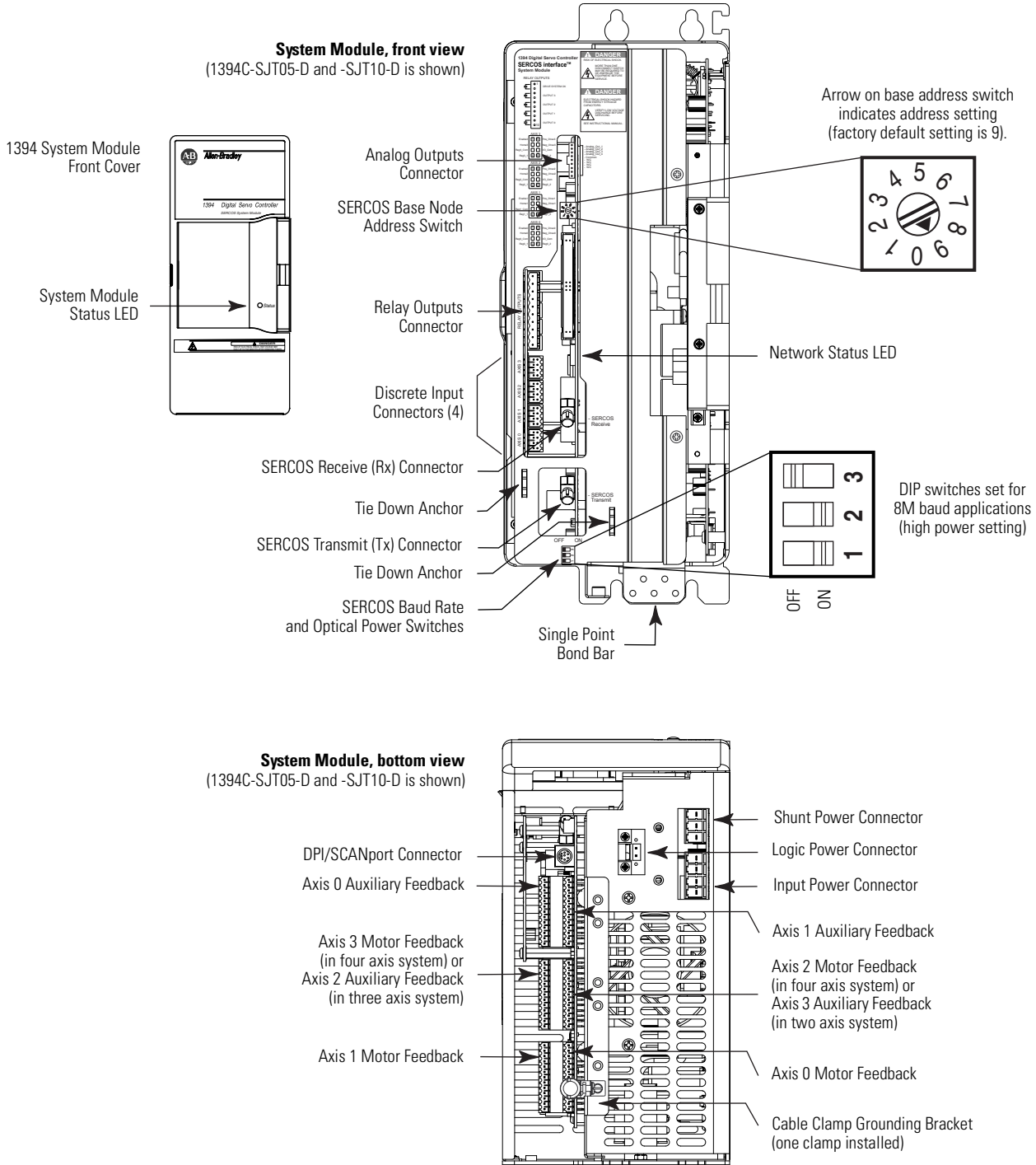

Note: Power, feedback, and I/O connectors are shown, however for wiring information, refer to the *1394 SERCOS Interface Installation Manual* (publication 1394-IN002x-EN-P).

Use the figure below to locate the 1394C-SJT22-D System Module connectors and indicators.

**Figure 1.2**  
**1394 System Modules (1394C-SJT22-D)**

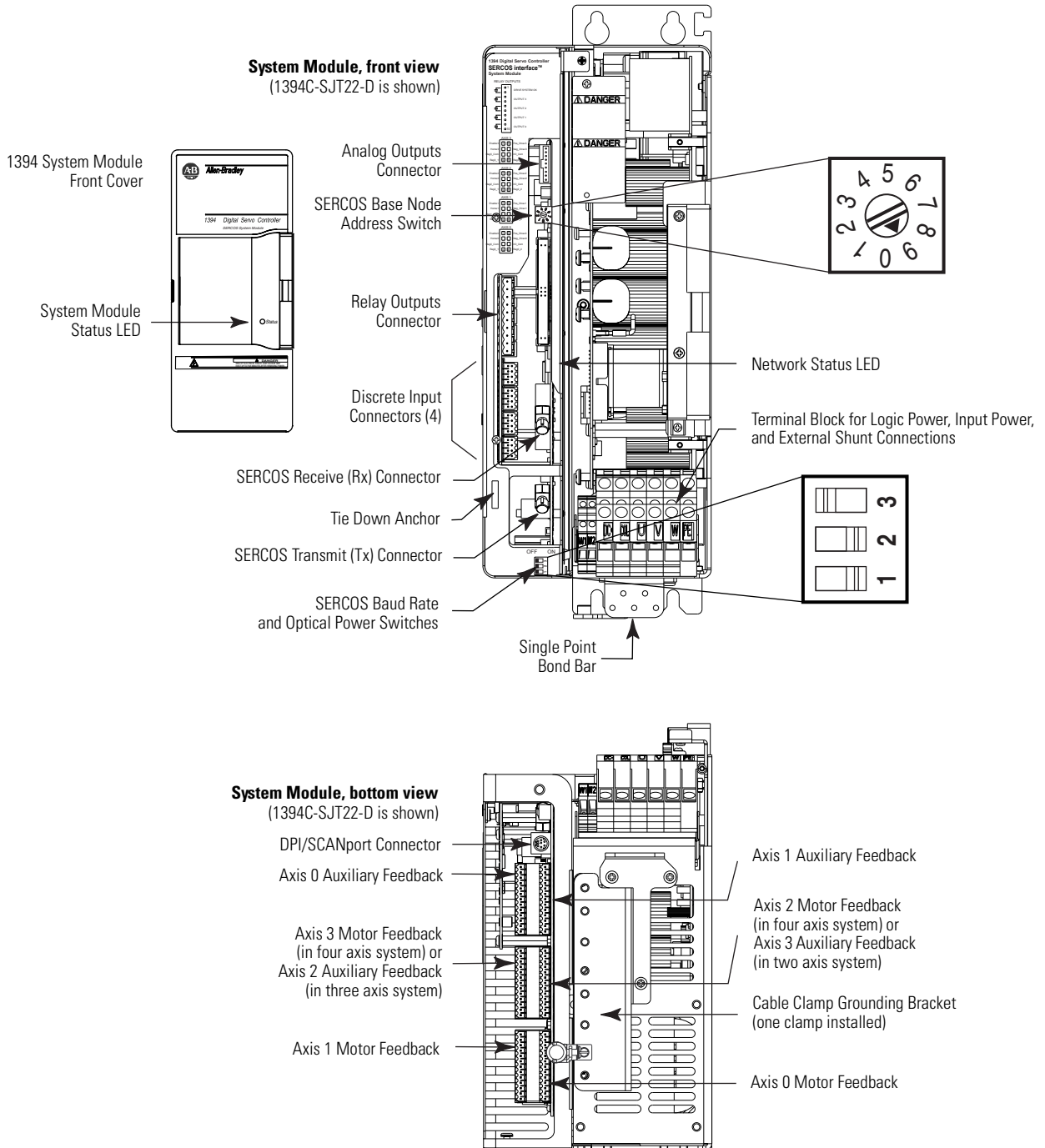

Note: Power, feedback, and I/O connectors are shown, however for wiring information, refer to the *1394 SERCOS Interface Installation Manual* (publication 1394-IN002x-EN-P).

## Locating Axis Module Connectors and Indicators

Use the figure below to locate the axis module connectors and indicators. Shown below are typical 1394C-AM03, -AM04, and -AM07 axis modules. Although the physical size of the 1394C-AM50-xx and AM75-xx model is larger, the location of the connectors and indicators is identical.

**Figure 1.3**  
**1394 Axis Modules (1394C-AMxx and -AMxx-IH)**

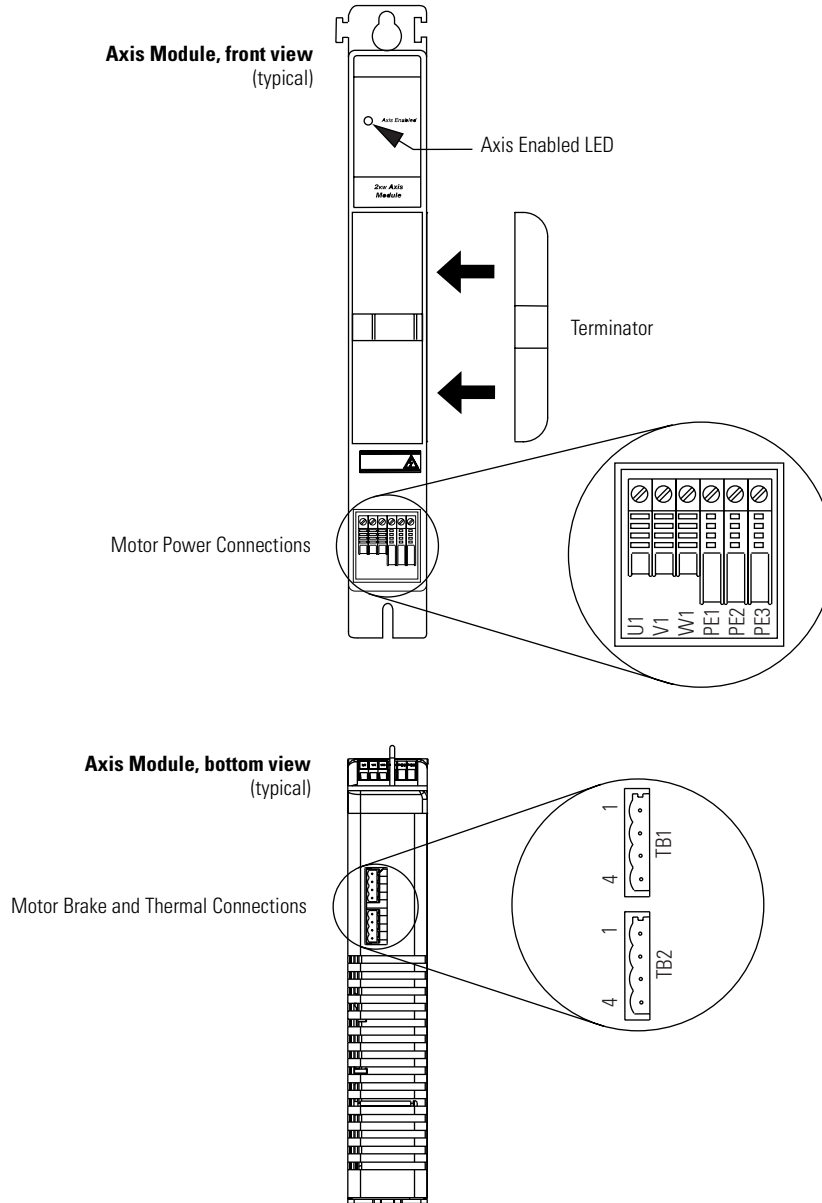

Note: Power and filter connectors are shown, however for wiring information, refer to the *1394 SERCOS Interface Installation Manual* (publication 1394-IN002x-EN-P).

## Locating SERCOS Interface Fiber-Optic Connectors

Use the figure below to locate the SERCOS interface fiber-optic connectors. The fiber-optic ring is connected using the SERCOS Receive and Transmit connectors.

Note: Plastic cable is available in lengths up to 32 m (105.0 ft). Glass cable is available in lengths up to 200 m (656.7 ft).

**Figure 1.4**  
**ControlLogix and SoftLogix SERCOS Connector Locations**

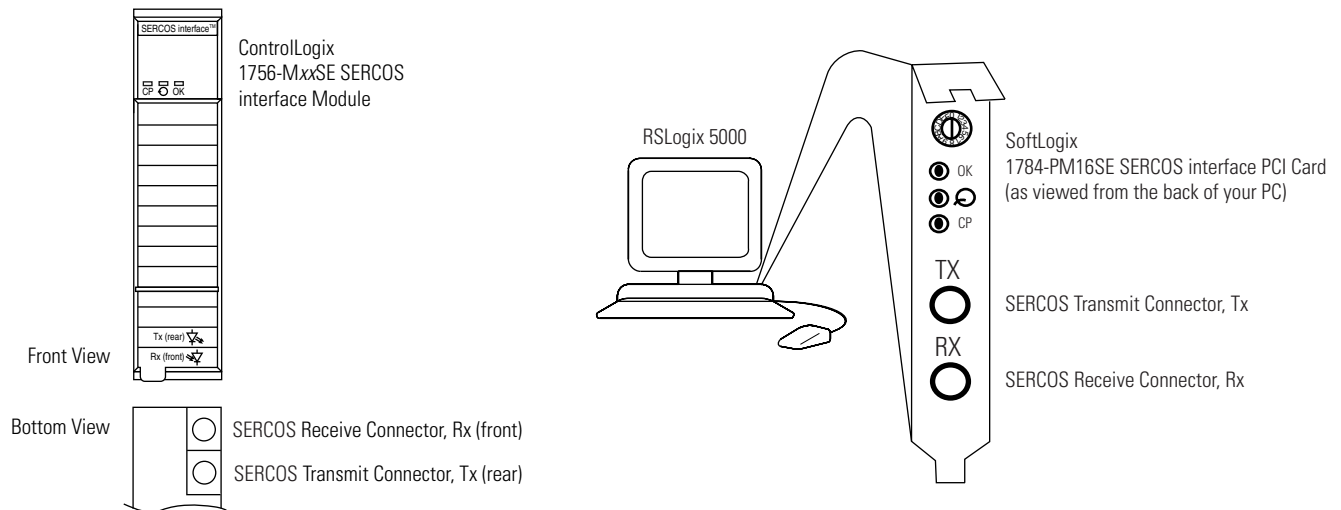

## Configuring Your 1394 SERCOS interface System

These procedures assume you have completed mounting, wiring, and connecting your SERCOS interface module and 1394 SERCOS interface drive as described in the *1394 SERCOS Interface Installation Manual* (publication 1394-IN002x-EN-P).

The procedures in this section apply to 1394 SERCOS interface drive components and describe how to:

- Configure your 1394 system module
- Configure your Logix SERCOS interface module using RSLogix™ 5000 software
- Download your program to your Logix controller
- Apply power to your 1394 drive components
- Test and tune your motor using RSLogix 5000 software

These procedures assume you have connected the fiber-optic cables between your 1394 system module and the ControlLogix chassis with 1756-MxxSE interface module or personal computer with 1784-PM16SE PCI card.

## Configuring Your 1394 System Module

To configure your 1394 system module:

1. Verify that there is no 360/480V AC input power or 24V logic power applied to the system and that the SERCOS fiber-optic cables are connected to the Tx and Rx connectors. To verify your fiber-optic cable connections, refer to the *1394 SERCOS Interface Installation Manual* (publication 1394-IN002x-EN-P).
2. Set the base node address for each 1394 controller in your system by setting the Base Address switch. Refer to the example table below for switch settings. Refer to figures 1.1 and 1.2 for switch location. Configurations with up to nine 1394 SERCOS interface system modules are possible.

For example, if the number of 1394 SERCOS interface system modules you have is:	Set the Base Address switch for system number:								
	1 to:	2 to:	3 to:	4 to:	5 to:	6 to:	7 to:	8 to:	9 to:
1	1	N/A	N/A	N/A	N/A	N/A	N/A	N/A	N/A
2	1	2	N/A	N/A	N/A	N/A	N/A	N/A	N/A
3	1	2	3	N/A	N/A	N/A	N/A	N/A	N/A
4	1	2	3	4	N/A	N/A	N/A	N/A	N/A
5	1	2	3	4	5	N/A	N/A	N/A	N/A
6	1	2	3	4	5	6	N/A	N/A	N/A
7	1	2	3	4	5	6	7	N/A	N/A
8	1	2	3	4	5	6	7	8	N/A
9	1	2	3	4	5	6	7	8	9

Note: Base address 0 is used for troubleshooting and not a valid setting for normal operation.



Refer to Figure 1.5 for an example of the fiber-optic ring connections between the 1394 system module(s) and the SoftLogix PCI card. Although Figure 1.5 only illustrates the SERCOS fiber-optic ring with the SoftLogix PCI card, node addressing for SoftLogix is done the same way as shown in the ControlLogix example.

**Figure 1.5**  
**Fiber-Optic Ring Connection (SoftLogix)**

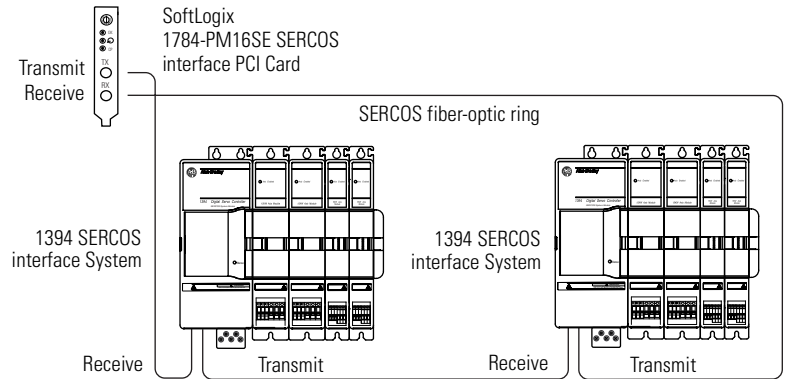

Axis 0 of each system module has a node address of the switch setting times 10 (for example: system number 1 times 10 = 10 and axes 1-3 on this system are numbered 11, 12, and 13, respectively). Refer to Figure 1.6 for an example of how node addresses are assigned.

**Figure 1.6**  
**Axis Module Node Addresses**

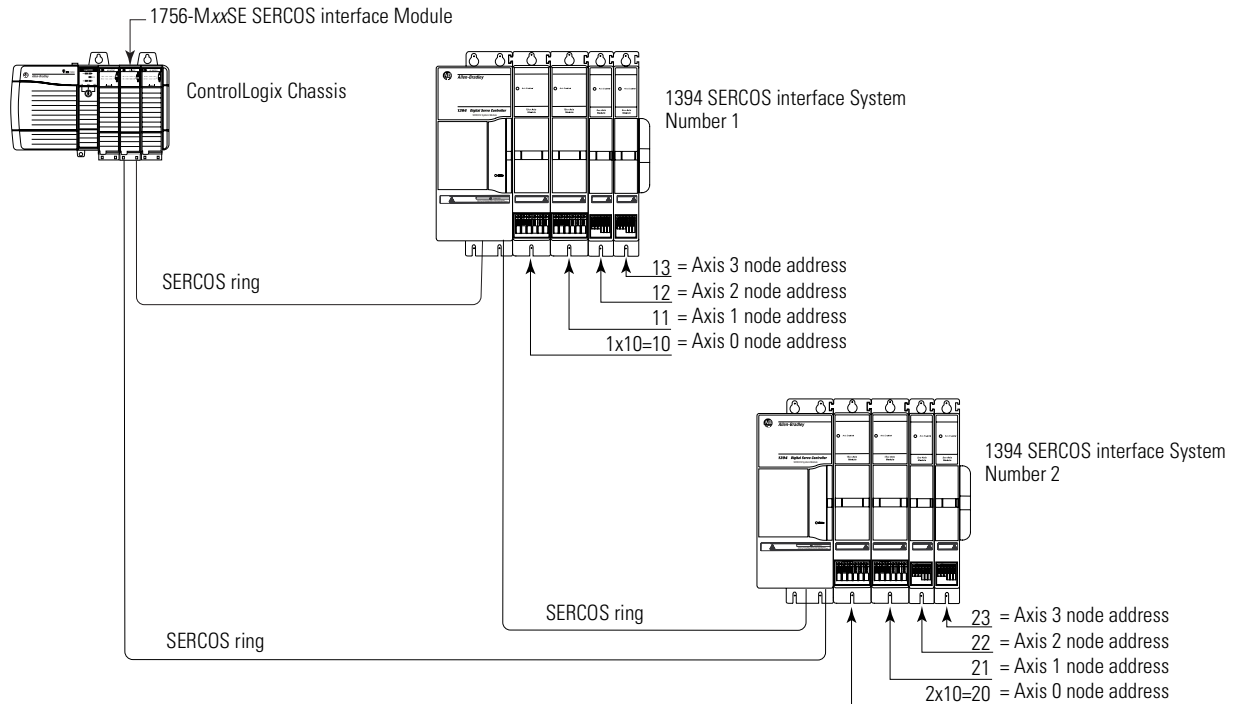

3. Set the baud rate using DIP switches 2 and 3. Refer to the table below for baud rate switch settings. Refer to figures 1.1 and 1.2 for DIP switch location.

For this baud rate:	Set switch 2:	Set switch 3:
2M baud	OFF	OFF
4M baud	OFF	ON
8M baud	ON	OFF

4. Set the SERCOS optical power level to **High** using DIP switch 1, as shown in Figure 1.7. Refer to the table below for optical power level switch settings. Refer to Figure 1.1 for the optical power switch location.

For this transmit level:	Set switch 1:
Low	OFF
High	ON

**Figure 1.7**  
**SERCOS Baud Rate and Optical Power DIP Switches**

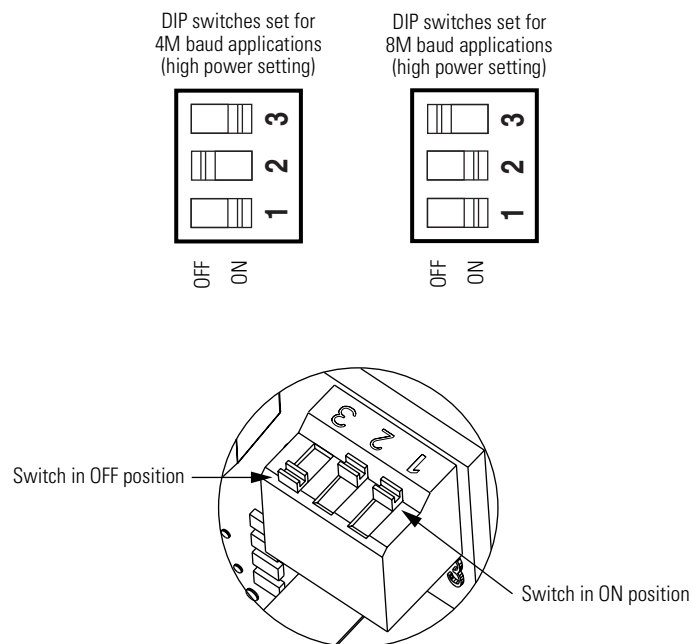

## Configuring Your Logix SERCOS interface Module

This procedure assumes that you have finished wiring your 1394 SERCOS interface system and have finished configuring the 1394 system module switches.

For greater detail on the RSLogix 5000 software as it applies to ControlLogix and SoftLogix modules, refer to the table below for the appropriate publication.

For:	Refer to this Document	Publication Number:
Detailed information on configuring and troubleshooting your ControlLogix motion module	<i>ControlLogix Motion Module Setup and Configuration Manual</i>	1756-UM006x-EN-P
Detailed information on configuring and troubleshooting your SoftLogix PCI card	<i>SoftLogix Motion Card Setup and Configuration Manual</i>	1784-UM003x-EN-P

If you have already configured your Logix module using one of the setup and configuration manuals listed above, go directly to *Applying Power to the 1394 SERCOS interface System* (page 1-20). If not, go to *Configuring Your Logix Controller* beginning below.

## Configuring Your Logix Controller

To configure your Logix controller:

1. Apply power to your Logix chassis/PC containing the SERCOS interface module and open your RSLogix 5000 software.
2. Select **New** in the File menu. The New Controller window opens.
  - Select controller type
  - Name the file
  - Select the ControlLogix chassis size
  - Select the ControlLogix processor slot
3. Select **OK**.
4. Select **Controller Properties** in the edit menu. The Controller Properties window opens.

5. Select the **Date and Time** tab.

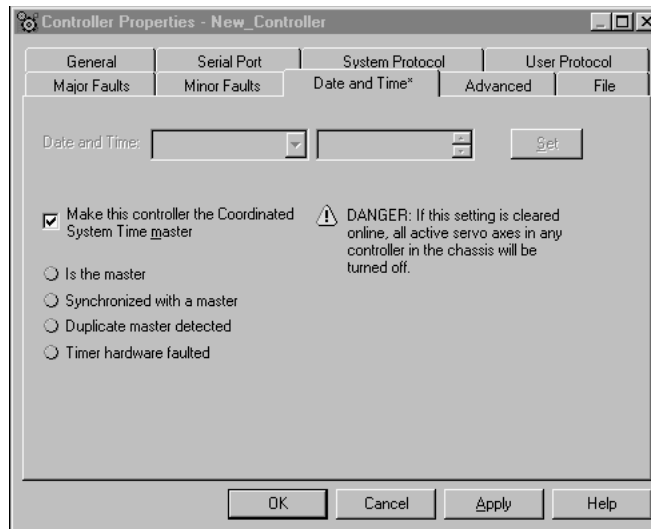

6. Check the box **Make this controller the Coordinated System Time master**.

---

**IMPORTANT**

Only one ControlLogix processor can be assigned as the Coordinated System Time master.

---

7. Select **OK**.

## Configuring Your Logix Module

To configure your Logix module:

1. Right-click on I/O Configuration in the explorer window and select **New Module**. The Select Module Type window opens.
2. Select **1756-MxxSE** or **1784-PM16SE** as appropriate for your actual hardware configuration.
3. Select **OK**. The Module Properties wizard opens.

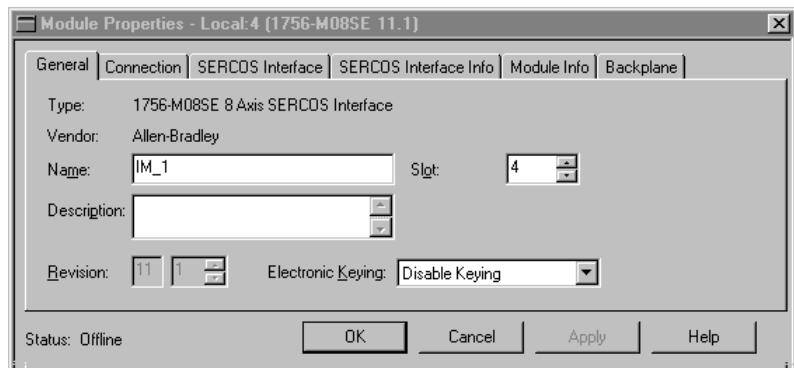

- Name the module
  - Select the slot where your module resides
  - Select an Electronic Keying option.
4. Select **Next** until the following screen opens.

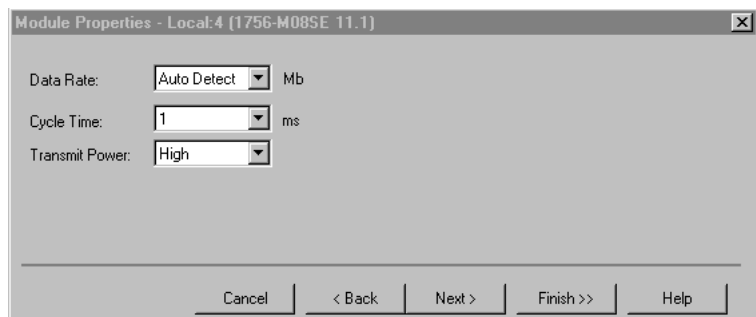

5. Select **Data Rate**, **Cycle Time**, and **Optical Power** settings.

- Ensure the Data Rate setting matches DIP switches 2 and 3 (baud rate) as set on the system module, or use the Auto Detect setting.
- Set the Cycle Time according to the table below.

Logix SERCOS Module	1394 SERCOS interface System Module Series	Data Rate Mbit/s	SERCOS Ring Cycle Time ms	Number of Axes
1756-M08SE (Series A)	C or D	4	0.5	N/A
			1.0	up to 4
			2.0	up to 8
1756-M08SE (Series B)	D only	8	0.5	N/A
			1.0	up to 8
			2.0	
1756-M16SE or 1784-PM16SE	C or D	4	0.5	N/A
			1.0	up to 4
			2.0	up to 8
	D only	8	0.5	N/A
			1.0	up to 8
			2.0	up to 16

- Ensure the Optical Power setting (high or low) matches DIP switch 1 as set on the system module.

6. Select **Finish**. Your new module appears under the I/O Configuration folder in the explorer window.
7. Repeat steps 1-6 for each Logix module.

## Configuring Your 1394 System Module

To configure your 1394 system module:

1. Right-click on the new module you just created and select **New Module**. The Select Module Type window opens.
2. Select your 1394C-SJTxx-D system module.
3. Select **OK**. The Module Properties window opens.
  - Name the module
  - Set the Base Node address

Note: Set node address in the software to match the node setting on the drive. Refer to *Configuring Your 1394 System Module*, step 2, page 1-8.

  - Select an Electronic Keying option
4. Select **Next** until the following window opens.

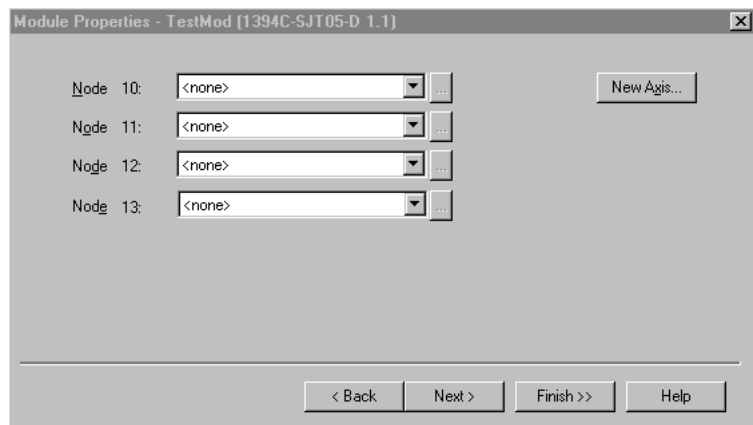

5. Select the **New Axis** button. The New Tag window opens.
6. Provide/Select the following New Tag attributes:
  - Axis name
  - **AXIS\_SERVO\_DRIVE** as the Data Type
7. Select **OK**.
8. Repeat steps 5 and 6 for each axis. The axes appear under the Ungrouped Axes folder in the explorer window.

9. Assign each axis to a node address (as shown in the window below).

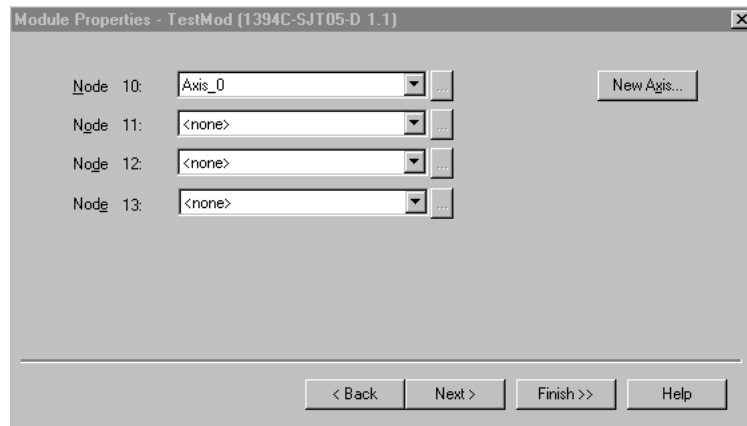

10. Select **Next** until the following window opens.

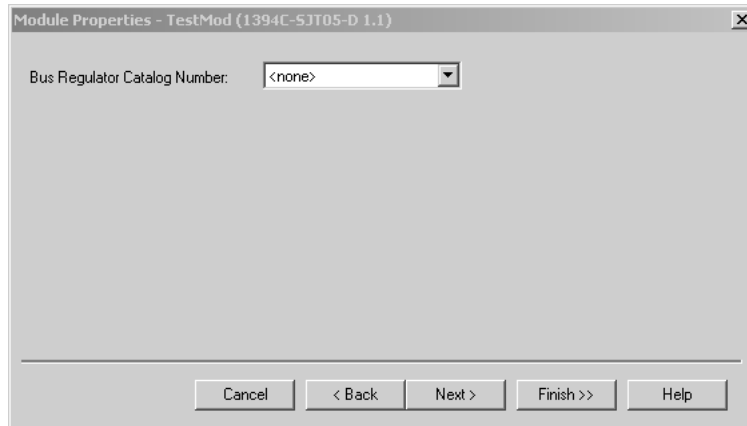

11. Select the Bus Regulator Catalog Number (shunt option) as appropriate for your actual hardware configuration.

<b>If your hardware configuration includes this shunt option:</b>	<b>Then select:</b>
1394C-SJT05-D or -SJT10-D with internal shunt only	Internal or <none>
1394C-SJT05-D or -SJT10-D with optional external shunt	1394-SR10A
1394C-SJT22-D with required external shunt	1394-SR9A, -SR9AF, -SR36A, or -SR36AF

12. Select **Finish**.

13. Repeat steps 1-12 for each 1394 system module. The axes appear under the Ungrouped Axes folder in the explorer window.



## Configuring the Motion Group

To configure the motion group:

1. Right-click Motion Groups in the explorer window and select **New Motion Group**. The New Tag window opens.
2. Name new motion group.
3. Select **OK**. New group appears under Motion Groups folder.
4. Right-click on the new motion group and select **Properties**. The Motion Group Properties window opens.

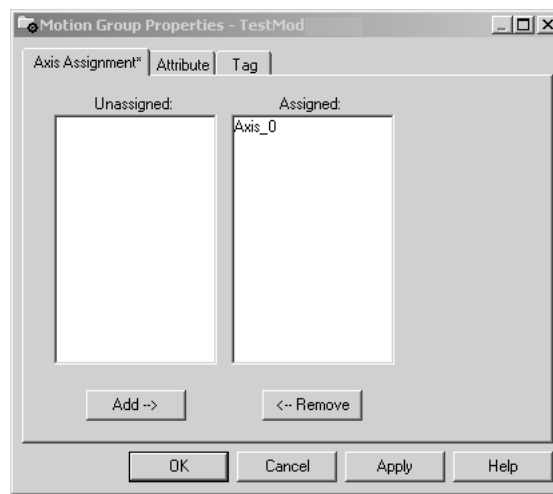

5. Select the **Axis Assignment** tab and move your axes (created earlier) from *Unassigned* to *Assigned*.
6. Select the **Attribute** tab and edit the default values as appropriate for your application.
7. Select **OK**.

## Configuring Axis Properties

To configure axis properties:

1. Right-click on an axis in the explorer window and select **Properties**. The Axis Properties window opens.

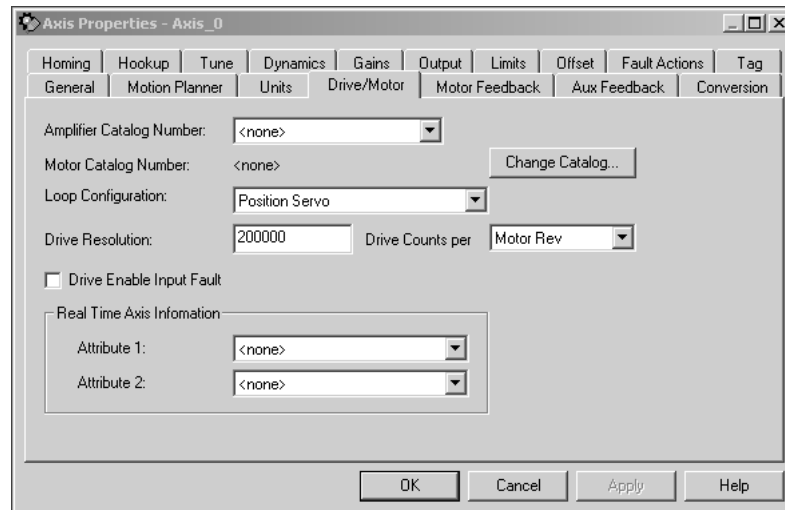

2. Select the **Drive/Motor** tab.

- Set the Amplifier (system module) Catalog Number
- Set the Motor Catalog Number
- Set Loop Configuration to Position Servo

Note: For amplifier and motor catalog numbers refer to the amplifier and motor name plate.

3. Select the **Motor Feedback** tab and verify the Feedback Type shown is appropriate for your actual hardware configuration.
4. Select the **Units** tab and edit default values as appropriate for your application.
5. Select the **Conversion** tab and edit default values as appropriate for your application.

6. Select the **Fault Actions** tab and click on the Set Custom Stop Action... tab. The Custom Stop Action Attributes window opens.

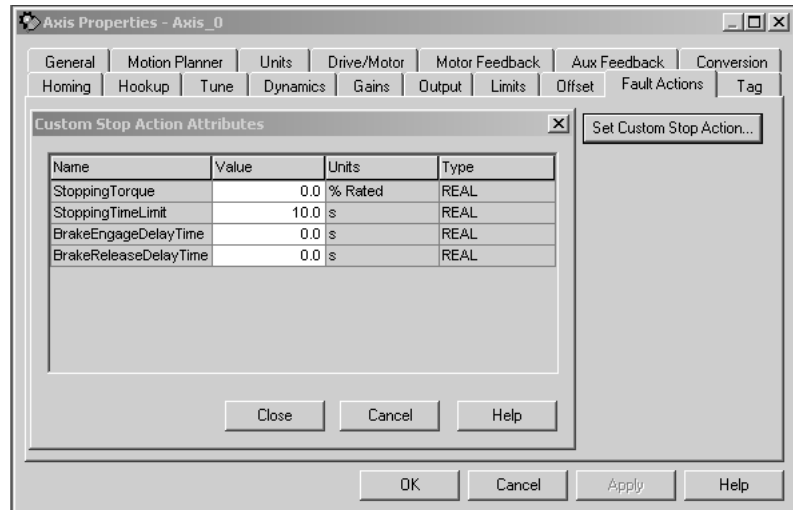

- Set the Brake Engage Delay Time (refer to *Brake Interconnect Diagrams* in *Appendix A* for specific values).
  - Set the Brake Release Delay Time (refer to *Brake Interconnect Diagrams* in *Appendix A* for specific values).
  - Select **Close**.
7. Select **OK**.
  8. Repeat steps 1-7 for each 1394 axis module.
  9. Verify your Logix program and save the file.

## Downloading Your Program

After completing the Logix configuration you must download your program to the Logix processor.

## Applying Power to the 1394 SERCOS interface System

This procedure assumes that you have wired your 1394 SERCOS interface system, your SERCOS interface module and verified the wiring. To apply power to your 1394 system:

1. Apply 24V logic power to the system module and verify that the logic power voltage at the input terminals of the system module is 24V AC (or 24V DC)  $\pm 10\%$ .
2. Observe the status LED on the system module.

<b>If the system module LED:</b>	<b>Do This:</b>
Alternates red and green	System module ready. Go to step 3.
Does not alternate red and green	Go to the chapter <i>Troubleshooting Your 1394 SERCOS Interface System</i> .

3. Observe the three SERCOS LEDs on the SERCOS interface module.

<b>If the three SERCOS LEDs:</b>	<b>Then:</b>
Flash green and red	Establishing communication (wait for steady green on all three LEDs).
Illuminates steady green	Communication ready. Go to step 4.
Is not flashing or steady green	Go to the appropriate Logix motion module setup and configuration manual for specific instructions and troubleshooting.

4. Observe the network status LED on the system module.

<b>If the network status LED:</b>	<b>Then:</b>
Flashes green	Establishing communication (wait for steady green).
Illuminates steady green	Communication ready. Go to step 5.
Is not flashing or steady green	Go to the chapter <i>Troubleshooting Your 1394 SERCOS Interface System</i> .

5. Observe the status LEDs on the axis modules.

<b>If the axis module LED:</b>	<b>Then:</b>
Alternates red and green	Axis module ready. Go to step 7.
Does not alternate red and green	Go to the chapter <i>Troubleshooting Your 1394 SERCOS Interface System</i> .

6. Disconnect the load from the motor(s).

**ATTENTION**



To avoid personal injury or damage to equipment, disconnect the load from the motor(s). Ensure each motor is free of all linkages when initially applying power to the system.

7. Apply main input power.
8. Verify that the main input phase-to-phase voltage is present at the input terminals of the system module or at the user-supplied input contactor.

<b>If the voltage measured between terminals:</b>	<b>Is:</b>	<b>Then:</b>
U and W	324-528V ac	Go to step 9.
	Not within 324-528V ac	Go to the chapter <i>Troubleshooting Your 1394 SERCOS Interface System</i> .

- 9.

<b>If the voltage measured between terminals:</b>	<b>Is:</b>	<b>Then:</b>
V and W	324-528V ac	Go to step 10.
	Not within 324-528V ac	Go to the chapter <i>Troubleshooting Your 1394 SERCOS Interface System</i> .

10. Observe the status LED on the system module.

<b>If the system module LED:</b>	<b>Then:</b>
Is flashing green	System module is ready. Go to step 11.
Is not flashing green	Go to the chapter <i>Troubleshooting Your 1394 SERCOS Interface System</i> .

11. Observe the status LED on the axis modules.

<b>If the axis module LED:</b>	<b>Then:</b>
Is flashing green	Axis module is ready. Go to the section <i>Testing and Tuning Your Axes</i> .
Is not flashing green	Go to the chapter <i>Troubleshooting Your 1394 SERCOS Interface System</i> .

## Testing and Tuning Your Axes

This procedure assumes that you have configured your 1394 SERCOS interface system, your SERCOS interface module, and applied power to the system.

### IMPORTANT

Before proceeding with testing and tuning your axes, verify that the system and axis status LEDs are as described in the table below.

<b>Status LED:</b>	<b>Must be:</b>	<b>Status:</b>
System Module (on front cover)	Flashing green	System module is ready.
Axis Module	Flashing green	Axis module is ready.
Network (inside front cover)	Illuminates steady green	Communication ready.

For greater detail on the RSLogix 5000 software as it applies to ControlLogix and SoftLogix modules, refer to the table below for the appropriate publication.

<b>For:</b>	<b>Refer to this Document</b>	<b>Publication Number:</b>
Detailed information on configuring and troubleshooting your ControlLogix motion module	<i>ControlLogix Motion Module Setup and Configuration Manual</i>	1756-UM006x-EN-P
Detailed information on configuring and troubleshooting your SoftLogix PCI card	<i>SoftLogix Motion Card Setup and Configuration Manual</i>	1784-UM003x-EN-P

If you have already tested and tuned your axes using one of the setup and configuration manuals listed above, you are finished commissioning your 1394 SERCOS interface system. If not, go to *Testing Your Axes* beginning below.

## Testing Your Axes

To test your axes:

1. Verify the load was removed from each axis.
2. Right-click on an axis in your Motion Group folder in the explorer window and select **Axis Properties**. The Axis Properties window appears.
3. Select the **Hookup** tab.

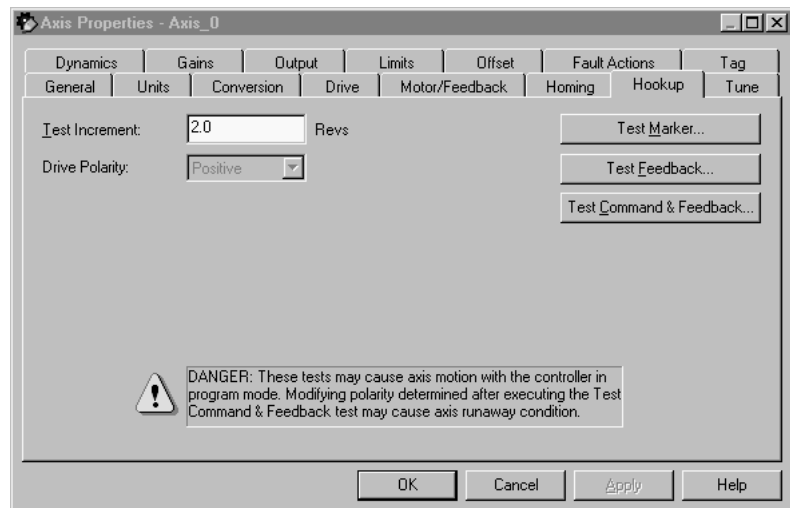

4. Select **2.0** as the number of revolutions for the test (or another number more appropriate for your application).

This Test:	Performs this Test:
Test Marker	Verifies marker detection capability as you manually rotate the motor shaft.
Test Feedback	Verifies feedback connections are wired correctly as you manually rotate the motor shaft.
Test Command & Feedback	Verifies motor power and feedback connections are wired correctly as you command the motor to rotate. Also, allows you to define polarity.

5. Apply ENABLE input signal (Axis\_*x* pin 1) for the axis you are testing.

**ATTENTION**

To avoid personal injury or damage to equipment, apply 24V ENABLE signal (Axis\_*x* pin 1) only to the axis you are testing.

6. Select the **Test** (Marker/Feedback/Command & Feedback) button to verify connections. The Online Command window opens. Follow the on-screen test instructions. When the test completes, the Command Status changes from *Executing* to *Command Complete*.

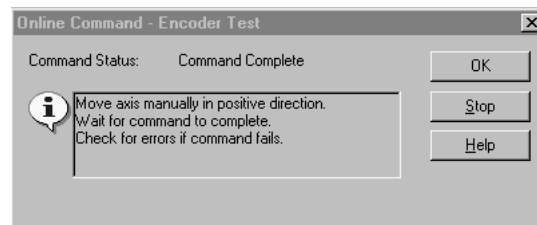

7. Select **OK**.
8. The Online Command - Apply Test window opens (Feedback and Command & Feedback tests only). When the test completes, the Command Status changes from *Executing* to *Command Complete*.

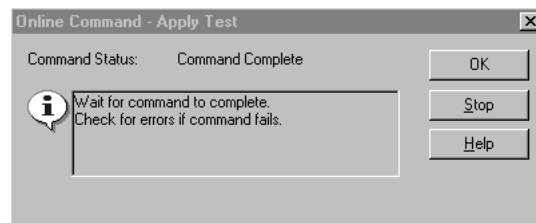

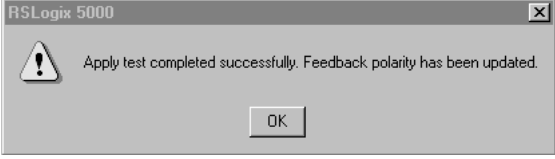
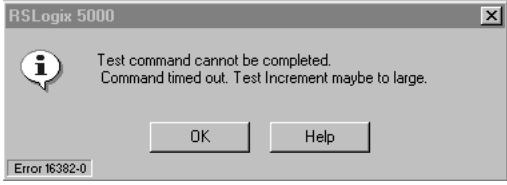

9. Select **OK**.

<b>If:</b>	<b>Then:</b>
<p>Your test completes successfully, this window appears:</p> 	<ol style="list-style-type: none"> <li>1. Select <b>OK</b>.</li> <li>2. Remove the ENABLE input signal (Axis_<i>x</i> pin 1) applied earlier.</li> <li>3. Go to <i>Tuning Your Axes</i>.</li> </ol>
<p>Your test failed, this window appears:</p> 	<ol style="list-style-type: none"> <li>1. Select <b>OK</b>.</li> <li>2. Verify that the main three-phase bus power is up.</li> <li>3. Verify that the ENABLE input signal (Axis_<i>x</i> pin 1) is applied to the axis you are testing.</li> <li>4. Verify conversion constant entered in the Conversion tab.</li> <li>5. Return to step 6 and run the test again.</li> </ol>

## Tuning Your Axes

To tune your axes:

1. Verify the load is still removed from the axis being tuned.

### ATTENTION



To reduce the possibility of unpredictable motor response, tune your motor with the load removed first, then re-attach the load and perform the tuning procedure again to provide an accurate operational response.

2. Select the **Tune** tab.

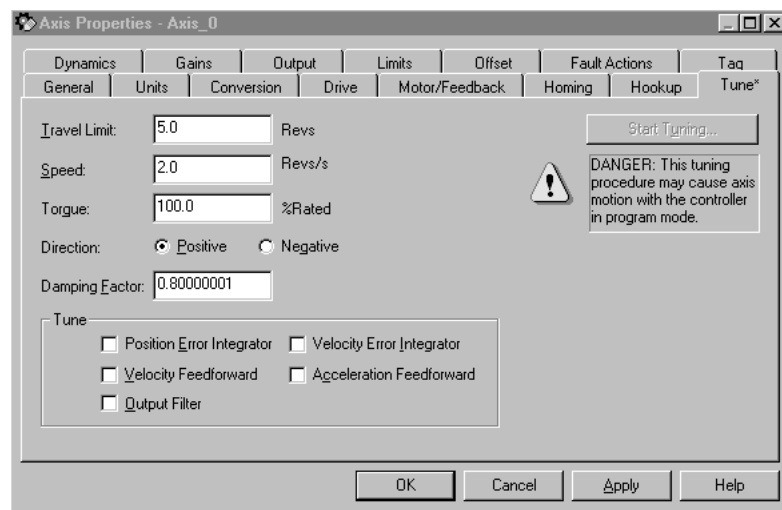

3. Enter values for Travel Limit and Speed. In this example, Travel Limit = 5 and Speed = 2.

Note: Actual value of programmed units depend on your application. For more information, contact Allen-Bradley technical support.

4. Check **Tune** boxes as appropriate for your application.
5. Apply ENABLE input signal (Axis\_x pin 1) for the axis you are tuning.

### ATTENTION



To avoid personal injury or damage to equipment, apply 24V ENABLE signal (Axis\_x pin 1) only to the axis you are tuning.

6. Select the **Start Tuning** button to auto-tune your axis. The Online Command - Tune Servo window appears. When the test completes, the Command Status changes from *Executing* to *Command Complete*.

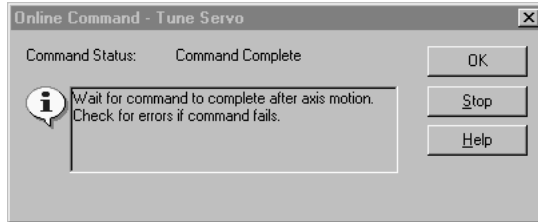

7. Select **OK**. The Tune Bandwidth window opens.

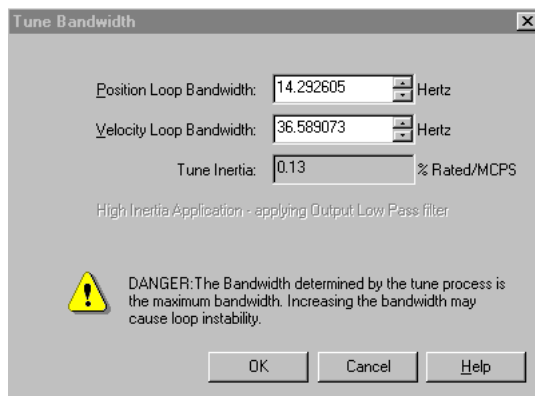

Note: Actual bandwidth values (Hz) depend on your application and may require adjustment once motor and load are connected.

Record your bandwidth data for future reference.

8. Select **OK**.
9. The Online Command - Apply Tune window opens. When the test completes, the Command Status changes from *Executing* to *Command Complete*.

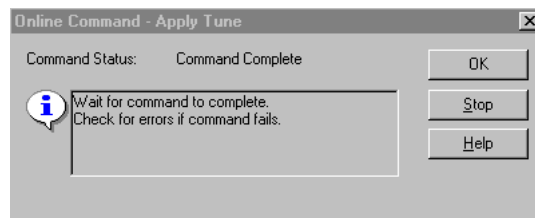

**10. Select **OK**.**

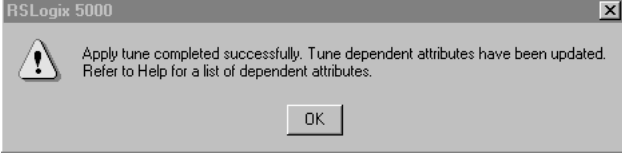
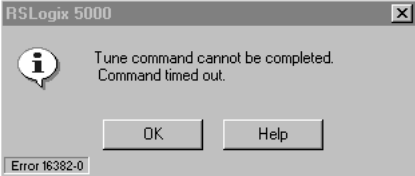
<b>If:</b>	<b>Then:</b>
<p>Your test completes successfully, this window appears:</p>  <p>The screenshot shows a dialog box titled 'RSLogix 5000' with a warning icon. The text inside reads: 'Apply tune completed successfully. Tune dependent attributes have been updated. Refer to Help for a list of dependent attributes.' There is an 'OK' button at the bottom.</p>	<ol style="list-style-type: none"> <li>1. Select <b>OK</b>.</li> <li>2. Remove the ENABLE input signal (Axis_x pin 1) applied earlier.</li> <li>3. Go to step 11.</li> </ol>
<p>Your test failed, this window appears:</p>  <p>The screenshot shows a dialog box titled 'RSLogix 5000' with an information icon. The text inside reads: 'Tune command cannot be completed. Command timed out.' There are 'OK' and 'Help' buttons at the bottom. An error code 'Error 16382-0' is visible in the bottom left corner.</p>	<ol style="list-style-type: none"> <li>1. Select <b>OK</b>.</li> <li>2. Make an adjustment to motor velocity.</li> <li>3. Refer to appropriate Logix motion module setup and configuration manual for more information.</li> <li>4. Return to step 6 and run the test again.</li> </ol>

**11. Repeat *Testing and Tuning Your Axes* for each axis.**

# **Troubleshooting Your 1394 SERCOS Interface System**

## **Chapter Objectives**

This chapter covers:

- Safety Precautions
- Understanding How to Detect a Problem
- Troubleshooting System and Axis Module LEDs
- Troubleshooting the SERCOS Network Status LED
- Troubleshooting General System Problems
- Troubleshooting System and Axis Module Faults
- Troubleshooting General System Problems
- Understanding Logix/Drive Fault Behavior
- Supplemental Troubleshooting Information
- Replacing System and Axis Modules

## Safety Precautions

Observe the following safety precautions when troubleshooting your 1394 SERCOS interface system.

---

**ATTENTION**

DC bus capacitors may retain hazardous voltages after input power has been removed, but will normally discharge in several seconds. Before working on the drive, measure the DC bus voltage to verify it has reached a safe level or wait the full time interval listed on the warning on the front of the drive. Failure to observe this precaution could result in severe bodily injury or loss of life.

Do not attempt to defeat or override the drive fault circuits. You must determine the cause of a fault and correct it before you attempt to operate the system. If you do not correct a drive or system malfunction, it could result in personal injury and/or damage to equipment as a result of uncontrolled machine system operation.

If you use an oscilloscope (or chart recorder) for troubleshooting, you must properly ground it. The oscilloscope chassis can be at a potentially fatal voltage if you do not properly ground it. Always connect the oscilloscope chassis to an earth ground.

---

## Understanding How to Detect a Problem

When a drive fault occurs, the LED on the front panel changes and a fault message is transmitted to the position controller.

The majority of 1394 faults cause the Drive System OK contact to open. If a drive fault occurs, you can reset the fault detection circuitry by removing and reapplying logic power. However, if it is a hardware fault, you need to correct the fault before restarting.

---

**IMPORTANT**

You can also reset a fault condition using RSLogix 5000 software.

---

This material, along with the diagnostic/troubleshooting information included with the position controller, will help you identify most common system malfunctions and determine which module that problem pertains to.

## Troubleshooting System and Axis Module LEDs

The system module Status LED is visible from the front of the module. Refer to figures 1.1 and 1.2 for the location of the system module status LED.

If the System Module LED is:	Potential Cause is:	Possible Resolution is:
<b>Steady red</b>	Terminator not installed.	<ul style="list-style-type: none"> <li>• Install terminator.</li> </ul>
	Malfunctioning system module.	<ul style="list-style-type: none"> <li>• Verify wiring.</li> <li>• Secure wiring connections.</li> <li>• Replace the module.</li> <li>• Check logic supply ratings.</li> <li>• Contact your local Allen-Bradley Support Representative.</li> </ul>
<b>Flashing red</b>	A fault has occurred in the system (check for faults through the RSLogix 5000, DriveExplorer™, or the HIM).	<ul style="list-style-type: none"> <li>• Reset faults.</li> <li>• Verify wiring.</li> <li>• Secure wiring connections.</li> <li>• Check SERCOS fiber-optic connections.</li> </ul>
<b>Alternating red and green</b>	DC bus is not up.	Apply three-phase power.
	Open fuse or malfunctioning contactor on user-supplied 3 phase input.	<ul style="list-style-type: none"> <li>• Check wiring to start/stop circuitry.</li> <li>• Check the user program.</li> <li>• Check fuse.</li> </ul>
	Malfunctioning system module.	Replace the module.
<b>Steady green</b>	The bus is up and axes are enabled.	None needed.
<b>Flashing green</b>	The bus is up, but no axis is enabled.	<ul style="list-style-type: none"> <li>• Check axes and enable them, if necessary.</li> <li>• Verify that enable wiring is correct and not open.</li> </ul>
	Enable signal from position controller is not present.	<ul style="list-style-type: none"> <li>• Check axes and enable them, if necessary.</li> <li>• Verify that enable wiring is correct and not open.</li> <li>• Check I/O connections on control board.</li> </ul>
	Controller has detected a machine system malfunction and will not enable the 1394.	<ul style="list-style-type: none"> <li>• Check controller.</li> <li>• Check the machine.</li> </ul>
<b>Not illuminated</b>	There is no power to the system module.	<ul style="list-style-type: none"> <li>• Check 24V ac/dc logic power supply.</li> <li>• Check main ac input power supply.</li> </ul>

The axis module status LED is visible from the front of the module. Refer to Figure 1.3 for the location of the axis module status LED.

<b>If the Axis Module LED is:</b>	<b>Potential Cause is:</b>	<b>Possible Resolution is:</b>
<b>Steady red</b>	Malfunctioning axis module.	<ul style="list-style-type: none"> <li>• Verify wiring.</li> <li>• Verify that the slider and terminator connections are secure.</li> <li>• Secure wiring connections.</li> <li>• Replace the module.</li> </ul>
<b>Flashing red</b>	Axis fault has occurred.	<ul style="list-style-type: none"> <li>• Verify wiring.</li> <li>• Secure wiring connections.</li> <li>• Check fault status on the controller.</li> <li>• Check main ac input power.</li> <li>• Check axis status on the controller.</li> <li>• Verify that the terminator is present on the last axis.</li> </ul>
<b>Alternating red and green</b>	DC bus is not up.	<ul style="list-style-type: none"> <li>• Check the system module LED.</li> <li>• Check slider connections to verify that they are properly seated.</li> </ul>
<b>Steady green</b>	The bus is up and axes are enabled.	None needed.
<b>Flashing green</b>	Axis is not enabled.	<ul style="list-style-type: none"> <li>• Check axes and enable them, if necessary.</li> <li>• Verify that enable wiring is correct and not open.</li> </ul>
	Enable signal from controller is not present.	<ul style="list-style-type: none"> <li>• Check axes and enable them, if necessary.</li> <li>• Verify that enable wiring is correct and not open.</li> </ul>
	Incorrect wiring or loose connections.	Check I/O connections on the control board.
	Axis setups may not be correct for the application.	<ul style="list-style-type: none"> <li>• Verify that axis definitions are correct.</li> <li>• Check tuning parameters.</li> </ul>
<b>Not illuminated</b>	There is no power to the axis module.	<ul style="list-style-type: none"> <li>• Verify that the slider connections are secure.</li> <li>• Verify that the terminator is secure on the last axis.</li> </ul>
	There is no power to the system.	<ul style="list-style-type: none"> <li>• Check system module power supply.</li> <li>• Verify that the terminator is present on the last axis.</li> </ul>



## Troubleshooting the SERCOS Network Status LED

The SERCOS Network Status LED is located on the system module control board and visible with the system module door open. Refer to figures 1.1 and 1.2 for the location of the SERCOS Network Status LED.

If the SERCOS Network Status LED is:	Status is:	Potential Cause is:	Possible Resolution is:
<b>Steady Green</b>	Communication ready	No faults or failures.	System is ready.
<b>Steady Orange</b>	Control board failure	Control board failure.	<ul style="list-style-type: none"> <li>• Cycle power.</li> <li>• Replace system module.</li> </ul>
		Hardware failure.	Replace system module.
<b>Flashing Green</b>	Establishing communication	System is still in the process of establishing SERCOS communication.	Wait for steady green LED status.
		Node address setting on the 1394 system module does not match SERCOS controller configuration.	Verify proper SERCOS base address switch setting (refer to figures 1.1 and 1.2 for switch location).
<b>Flashing Red</b>	No communication <sup>1</sup>	Loose fiber-optic connection.	Verify proper fiber-optic cable connections.
		Dirty fiber-optic cable connectors.	Remove foreign material from connector.
		Broken fiber-optic cable.	Replace fiber-optic cable.
		Weak fiber-optic signal due to long fiber-optic cable.	Set SERCOS transmit level to HIGH.
		Distorted fiber-optic signal due to short fiber-optic cables.	Decrease SERCOS transmit level of previous device in SERCOS ring.
		Receive fiber-optic cable connected to SERCOS transmit connector and visa versa.	Check proper SERCOS fiber-optic cable connections.

<sup>1</sup> Refer to *Fiber Optic Cable Installation and Handling Instructions* (publication 2090-IN010A-EN-P) for more information.

## Troubleshooting System and Axis Module Faults

Fault messages are transmitted to the SERCOS controller through the SERCOS ring and/or SCANport. The tables on the following pages provide a description of system and axis module faults, the potential cause, and possible resolutions.

Note: Fault messages are shown as seen in RSLogix software (**bold**) and when using the HIM or DriveExplorer (not bold).

### System Module Faults

Use the table below for troubleshooting system module faults.

<b>Fault Message</b> RSLogix (HIM):	<b>Description:</b>	<b>Potential Cause is:</b>	<b>Possible Resolution is:</b>
<b>DriveOvercurrent Fault</b> (Bus Overcurrent)	System module exceeded current rating.	Motor or transmission malfunction.	<ul style="list-style-type: none"> <li>• Check for proper motor sizing.</li> <li>• Check/replace transmission device.</li> <li>• Check/replace motor.</li> </ul>
		System module not properly sized.	<ul style="list-style-type: none"> <li>• Check for proper system module sizing.</li> <li>• Install larger kW rated system module.</li> </ul>
<b>DriveOvervoltage Fault</b> (Bus Overvoltage)	The DC bus voltage is above limits. If it exceeds (830V dc), a fault is sensed and the power supply is disabled.  Bus Voltage Operation Shunt turns on at 805V dc. Shunt turns off at 750V dc. Over voltage trip point is 825V dc. Under voltage trip point is 275V dc. Under voltage fault clears at 300V dc.	If this fault occurs when you power up the system module with the M-contactor, the power distribution impedance might be stiff or line voltage might be too high.	<ul style="list-style-type: none"> <li>• Perform line conditioning.</li> <li>• Verify that line voltage is within specifications.</li> </ul>
		The position controller acceleration / deceleration rate is incorrectly set.	Change the command profile to reduce speed or increase time.
		The system inertia is too high causing excessive energy to be returned to the power supply bus.	<ul style="list-style-type: none"> <li>• Change the command profile to reduce speed or increase time.</li> <li>• Use a larger external shunt resistor.</li> </ul>
		A vertical axis with insufficient counterbalancing is overdriving the servo motor and causing excessive energy to be returned to the power supply bus.	<ul style="list-style-type: none"> <li>• Use the external shunt resistor.</li> <li>• Increase the mechanical counter-balance on the machine.</li> </ul>
		Input line voltage exceeds the maximum input voltage rating.	Verify incoming main ac input voltage and change the supply source, if needed.
		Power Driver Board is malfunctioning and is incorrectly sensing the bus voltage.	Replace the system module.
		The shunt regulator or transistor has malfunctioned.	Replace the system module.
		External shunt regulator fuse has blown. Shunt type not selected properly.	Check and possibly replace the shunt resistor. Select proper shunt type.
<b>DriveUndervoltage Fault</b> (Bus Precharge)	The system module pre-charge cycle has failed.	The precharge circuit has malfunctioned.	<ul style="list-style-type: none"> <li>• Check main ac line voltage.</li> <li>• Check fusing.</li> <li>• Replace the system module.</li> </ul>
<b>DriveUndervoltage Fault</b> (Bus Undervoltage)	The DC power bus activates undervoltage limit when the bus drops to 275V dc or less. It will clear at 300V dc.	The voltage on the main ac input power is low.	<ul style="list-style-type: none"> <li>• Verify incoming AC voltage and change the supply source, if needed.</li> <li>• Check fusing.</li> </ul>
<b>DriveHardFault</b> (Can Init)	SCANport hardware initialization fault detected.	Control board hardware failure.	<ul style="list-style-type: none"> <li>• Cycle all input power.</li> <li>• If fault persists, replace system module.</li> </ul>

<b>Fault Message RSLogix (HIM):</b>	<b>Description:</b>	<b>Potential Cause is:</b>	<b>Possible Resolution is:</b>
<b>DriveHardFault</b> (Contactor Fault)	Three-phase power is either detected when it shouldn't be or not detected when it should be.	The contactor is welded or failed to open.	<ul style="list-style-type: none"> <li>• Correct wiring.</li> <li>• Replace the contactor.</li> </ul>
		The input wiring to your contactor is incorrect.	Correct wiring.
<b>MotFeedbackFault</b> (Fdbk Watch Dog)	A feedback hardware or software fault detected.	The feedback processor has faulted.	<ul style="list-style-type: none"> <li>• Cycle all input power.</li> <li>• If fault persists, replace system module.</li> </ul>
<b>GroundShortFault</b> (Ground Short)	Excessive ground current in the system module was detected.	Incorrect wiring.	<ul style="list-style-type: none"> <li>• Verify motor and ground wiring.</li> <li>• Replace cables.</li> </ul>
		Motor malfunction.	Check the resistance of each motor winding phase to case ground with an ohm meter. Readings should be in mega ohms.
		Axis Module IGBT malfunction.	Replace the axis module.
		Short to ground.	<ul style="list-style-type: none"> <li>• Replace the system or axis module.</li> <li>• Check grounding and incoming power wiring.</li> </ul>
<b>DriveHardFault</b> (IDMA Load)	Motor feedback hardware initialization fault detected.	Control board hardware failure.	<ul style="list-style-type: none"> <li>• Cycle all input power.</li> <li>• If fault persists, replace system module.</li> </ul>
<b>DriveHardFault</b> (Memory Init)	Memory hardware initialization fault detected.	Incorrect motor feedback wiring.	<ul style="list-style-type: none"> <li>• Load default parameters, save to non-volatile memory, and recycle power.</li> <li>• Reset the drive.</li> <li>• Replace the system module.</li> </ul>
		Improper feedback cable clamp attachment.	
		Control board hardware failure.	<ul style="list-style-type: none"> <li>• Cycle all input power.</li> <li>• If fault persists, replace system module.</li> </ul>
<b>DriveHardFault</b> (NV Mem Init)	Non-volatile memory is corrupt.	Control board software error.	<ul style="list-style-type: none"> <li>• Load default parameters, save to non-volatile memory, and recycle power.</li> <li>• Reset the drive.</li> <li>• Replace the system module.</li> </ul>
<b>DriveHardFault</b> (Objects Init)	Non-volatile memory is corrupt.	Control board hardware failure.	<ul style="list-style-type: none"> <li>• Load default parameters, save to non-volatile memory, and recycle power.</li> <li>• Reset the drive.</li> <li>• Replace the system module.</li> </ul>
<b>PowerPhaseLoss Fault</b> (Phase Loss Flt)	The three-phase input line is monitored and a fault will be issued whenever a phase loss is detected.	One or more input line fuses have opened.	Check fuses and replace, as necessary.
		Input line contactor malfunction.	<ul style="list-style-type: none"> <li>• Correct wiring.</li> <li>• Replace contactor.</li> </ul>
		Incorrect wiring.	Check main ac input power at system module.
<b>DriveHardFault</b> (SCANport Comm)	SCANport/DPI Communication Failed.	The SCANport/DPI device or cable is faulty.	Check SCANport/DPI connections.
<b>SERCOSFault</b> (SERCOS Ring Flt)	SERCOS ring not active after being active and operational.	SERCOS ring is physically broken.	<ul style="list-style-type: none"> <li>• Check fiber optic cable connections.</li> <li>• Replace fiber optic cable.</li> </ul>
		ControlLogix program is downloaded during operation (this causes SERCOS ring to cycle).	Wait for SERCOS ring to cycle and fault to reset.
<b>DriveHardFault</b> (SERCOS Init)	SERCOS hardware initialization fault detected.	Control board hardware failure.	<ul style="list-style-type: none"> <li>• Cycle all input power.</li> <li>• If fault persists, replace system module.</li> </ul>
<b>DriveHardFault</b> (Serial Ring Init)	Intermodule serial communication failed.	Terminator is not installed.	<ul style="list-style-type: none"> <li>• Verify that the slider and terminator connections are secure.</li> </ul>
		System module failure.	Replace the system module.

<b>Fault Message RSLogix (HIM):</b>	<b>Description:</b>	<b>Potential Cause is:</b>	<b>Possible Resolution is:</b>
<b>SERCOSFault</b> (SERCOS Same Addr)	Duplicate node address detected on SERCOS ring.		Verify that each SERCOS drive is assigned a unique node address.
<b>DriveOvervoltage Fault</b> (Shunt Time Out)	Shunt resistor continuous rating exceeded.	The regenerative energy produced by the motor exceeded the limit of the shunt resistor.	<ul style="list-style-type: none"> <li>• Use a properly sized shunt or modify duty cycle of the application.</li> <li>• System uses internal shunt and requires external shunt for additional capacity.</li> </ul>
<b>DriveOvertemp Fault</b> (Sys Overtemp)	The 1394 thermal sensor tripped when internal ambient temperature exceeded rating.	The fan on the system module or an axis module failed.	Replace the system or axis module.
		The cabinet ambient temperature is above rating.	Check the cabinet temperature.
		The machine duty cycle requires an RMS current exceeding the continuous rating of the controller.	Change the command profile to reduce speed or increase time.
		Changes in mechanics have occurred causing an increased torque output for the application move profiles.	<ul style="list-style-type: none"> <li>• Check mechanics for improper operation.</li> <li>• Verify operating torque.</li> </ul>
		The airflow access to the 1394 is limited or blocked.	Check airflow and re-route cables away from the 1394.
<b>DriveHardFault</b> (Sys Mod Unknown)	Active when serial ring detects unknown system module.	Unknown system module.	Replace the system module.
<b>DriveHardFault</b> (Task Init)	Software initialization fault detected.	Control board hardware failure.	<ul style="list-style-type: none"> <li>• Cycle all input power.</li> <li>• If fault persists, replace system module.</li> </ul>
<b>DriveHardFault</b> (Unknown Fault)	Fault is detected but source is unknown.	Wrong version of software for the hardware or loose internal or external connection.	<ul style="list-style-type: none"> <li>• Check system terminator.</li> <li>• Reset drive.</li> </ul>

## Axis Module Faults

Use the table below for troubleshooting axis module faults.

<b>Fault Message RSLogix (HIM):</b>	<b>Description:</b>	<b>Potential Cause is:</b>	<b>Possible Resolution is:</b>
<b>No Fault Message (condition indicated by on-screen message)</b> (A.x: ATune Flt)	Auto tune procedure failed to complete successfully.	Motor or feedback device malfunction.	<ul style="list-style-type: none"> <li>• Check motor power/feedback wiring.</li> <li>• Refer to on-screen message for resolution.</li> </ul>
<b>No Fault Message (condition indicated by on-screen message)</b> (Axis x Hookup Fault)	Hookup procedure failed to complete successfully.	Motor or feedback device malfunction.	<ul style="list-style-type: none"> <li>• Check motor power/feedback wiring.</li> <li>• Refer to on-screen message for resolution.</li> </ul>
<b>DriveHardFault</b> (Axis x Unknown)	Active when serial ring detects unknown axis module.	Unknown axis module.	<ul style="list-style-type: none"> <li>• Check the slider connections.</li> <li>• Replace the axis module.</li> </ul>
<b>AuxFeedbackFault</b> (A.x: Aux Fdbk AQB)	Auxiliary Encoder State Error	Auxiliary encoder has encountered an illegal state transition.	<ul style="list-style-type: none"> <li>• Use shielded cables with twisted pair wires.</li> <li>• Route the feedback away from potential noise sources.</li> <li>• Check the system grounds.</li> <li>• Replace the motor/encoder.</li> </ul>
<b>AuxFeedbackFault</b> (A.x: Aux Fdbk Comm)	Drive unable to communicate with auxiliary Smart feedback device.	The auxiliary encoder feedback signal is lost.	<ul style="list-style-type: none"> <li>• Check auxiliary feedback wiring.</li> <li>• Reset faults.</li> </ul>
<b>AuxFeedbackFault</b> (A.x: Aux Fdbk Loss)	The feedback wiring is open, shorted, or missing.	Open or short circuit has occurred on feedback wiring.	Check the feedback cable connectors/wiring to the system module and motor.
		The feedback wiring or termination to system module is incorrect.	Check the feedback cable connectors/wiring to the system module and motor.
		Motor feedback failure.	Replace the motor feedback.
<b>AuxFeedback NoiseFault</b> (A.x: Aux Fdbk Noise)	Excessive noise detected on feedback signals.	Poor grounding.	<ul style="list-style-type: none"> <li>• Check ground clamp connectors.</li> <li>• Check system module grounding.</li> </ul>
<b>DriveUndervoltage Fault</b> (A.x: Bus Loss)	The DC bus supply to the axis module was lost.	The slider connections may not be secure.	Check slider connections.
		An axis module's bus link fuse has blown.	Replace the axis module.
<b>DriveOvercurrent Fault</b> (A.x: Desat)	Too much current in the axis module.	Power module malfunction.	Replace the axis module.
<b>DriveEnableInput Fault</b> (Drive Enable Flt)	Missing Drive Enable Input Signal	<ul style="list-style-type: none"> <li>• An attempt was made to enable the axis through software while the Drive Enable hardware input was inactive.</li> <li>• The Drive Enable input transitioned from active to inactive while the axis was enabled.</li> </ul>	<ul style="list-style-type: none"> <li>• Disable the Drive Enable Input fault.</li> <li>• Verify that Drive Enable hardware input is active whenever the drive is enabled through software.</li> </ul>

<b>Fault Message RSLogix (HIM):</b>	<b>Description:</b>	<b>Potential Cause is:</b>	<b>Possible Resolution is:</b>
<b>PositionErrorFault</b> (Ax: Follow Error)	Axis position error limit has been exceeded. This fault can be configured for status only.	The motor cannot keep up with the position command.	<ul style="list-style-type: none"> <li>• Check motor load for binding.</li> <li>• Increase position loop proportional gain.</li> <li>• Increase the allowable following error.</li> </ul>
<b>DriveOvercurrent Fault</b> (Ax: I(t) Fault)	The output current is exceeding the time-current rating.	Accel/decel command from position controller is requiring peak current for an excessive amount of time.	Change the command profile to reduce speed or increase time.
		The machine friction, inertial load, and/or viscous load is excessive.	<ul style="list-style-type: none"> <li>• Change the command profile to reduce speed or increase time.</li> <li>• Check for mechanical problems on the machine.</li> </ul>
		The motor has been improperly sized.	<ul style="list-style-type: none"> <li>• Check motor size for your application.</li> <li>• Contact your Allen-Bradley Support Representative.</li> </ul>
		A short circuit exists across the drive output terminals.	Check wiring between the axis and the motor.
		Logic supply circuits have malfunctioned or AC output is incorrectly wired.	<ul style="list-style-type: none"> <li>• Check wiring between the axis and the motor.</li> <li>• Check power wiring between the axis and the motor.</li> <li>• Check resolver wiring between the system module and the motor.</li> </ul>
<b>PosSoftOvertravel Fault</b> (Ax: +Soft Ovrtrvl)	Axis position exceeded maximum software positive travel limit.	Positive travel limit set too high.	<ul style="list-style-type: none"> <li>• Jog motor to within limits.</li> <li>• Increase travel range limits.</li> </ul>
<b>NegSoftOvertravel Fault</b> (Ax: -Soft Ovrtrvl)	Axis position exceeded maximum software negative travel limit.	Negative travel limit set too low.	<ul style="list-style-type: none"> <li>• Jog motor to within limits.</li> <li>• Increase travel range limits.</li> </ul>
<b>PosHardOvertravel Fault</b> (Ax: +Hard Ovrtrvl)	Axis tripped positive hard overtravel limit switch.	Axis moved beyond the physical travel limits.	<ul style="list-style-type: none"> <li>• Disable checking and jog motor to within limits.</li> <li>• Move motor manually to within limits.</li> </ul>
<b>NegHardOvertravel Fault</b> (Ax: -Hard Ovrtrvl)	Axis tripped negative hard overtravel limit switch.	Axis moved beyond the physical travel limits.	<ul style="list-style-type: none"> <li>• Disable checking and jog motor to within limits.</li> <li>• Move motor manually to within limits.</li> </ul>
<b>MotFeedbackFault</b> (Ax: Mtr Fdbk AQB)	Motor Encoder State Error	Motor encoder has encountered an illegal state transition.	<ul style="list-style-type: none"> <li>• Use shielded cables with twisted pair wires.</li> <li>• Route the feedback away from potential noise sources.</li> <li>• Check the system grounds.</li> <li>• Replace the motor/encoder.</li> </ul>
<b>MotFeedbackFault</b> (Ax: Mtr Fdbk Comm)	Communication was not established with an intelligent (i.e. Stegmann) encoder.	The encoder feedback signal is lost.	<ul style="list-style-type: none"> <li>• Check motor feedback wiring</li> <li>• Reset faults</li> </ul>
<b>MotFeedbackFault</b> (Ax: Mtr Fdbk Loss)	The feedback wiring is open, shorted, or missing.	Open or short circuit has occurred on feedback wiring.	Check the feedback cable connectors/wiring to the system module and motor.
		The feedback wiring or termination to system module is incorrect.	Check the feedback cable connectors/wiring to the system module and motor.
		The motor feedback might be bad.	Replace the motor feedback.

<b>Fault Message RSLogix (HIM):</b>	<b>Description:</b>	<b>Potential Cause is:</b>	<b>Possible Resolution is:</b>
<b>MotFeedback NoiseFault</b> (Ax: Mtr Fdbk Noise)	Excessive noise detected on feedback signals.	Poor grounding.	<ul style="list-style-type: none"> <li>• Check ground clamp connectors.</li> <li>• Check system module grounding.</li> </ul>
<b>MotorOvertemp Fault</b> (Ax: Motor x Overtemp)	The motor thermal switch was tripped.	Motor overload.	<ul style="list-style-type: none"> <li>• Allow motor to cool down and investigate the cause of the motor overload.</li> <li>• Motor not sized properly.</li> </ul>
<b>OverSpeedFault</b> (Ax: Overspeed)	Motor velocity exceeded the overspeed trip limit.	Axis speed has reached 150% of the maximum rated setting. The 100% trip point is dictated by the lesser of the user velocity limits or the motor maximum speed rating.	<ul style="list-style-type: none"> <li>• Verify operating parameters.</li> <li>• Verify application requirements.</li> </ul>
<b>DriveOvertemp Fault</b> (Ax: Overtemp)	Axis module temperature limit exceeded	The fan on the system module or an axis module failed.	Replace the system or axis module.
		The cabinet ambient temperature is above rating.	Check the cabinet temperature.
		The machine duty cycle requires an RMS current exceeding the continuous rating of the controller.	Change the command profile to reduce speed or increase time.
		The airflow access to the 1394 is limited or blocked.	Check airflow and re-route cables away from the 1394.
<b>DriveOvercurrent Fault</b> (Ax: Power Fault)	The current through any one of the power IGBTs has exceeded 300% of the 1394's current rating.	The motor lead has shorted.	<ul style="list-style-type: none"> <li>• Check the motor cable.</li> <li>• Check the resistance of each power phase wire to ground. It should be Mega ohms.</li> <li>• Make sure ferrite cores are not installed on motor power conductors.</li> </ul>
		The motor is malfunctioning.	<ul style="list-style-type: none"> <li>• Check the resistance of each motor winding phase to case ground with an ohm meter. Readings should be in Mega ohms.</li> <li>• Return motor for repairs.</li> </ul>
		Power IGBTs are malfunctioning.	Replace the axis module.

## Troubleshooting General System Problems

Use the tables below for troubleshooting general system faults.

Condition:	Potential Cause is:	Possible Resolution is:
<b>Axis or System runs uncontrollably</b>	The position feedback device is incorrect or open.	Check wiring.
	Unintentionally in torque mode.	Check to see what primary operation mode was programmed.
	An internal malfunction exists.	Replace system or axis module.
<b>Axis or System is unstable</b>	Motor tuning parameters are set too high.	Run auto tune.
	Position loop gain or position controller accel/decel rate is improperly set.	Run auto tune.
	Improper grounding or shielding techniques are causing noise to be transmitted into the position feedback or velocity command lines, causing erratic axis movement.	Check wiring and ground.
	Motor Select parameter is incorrectly set (servo motor is not matched to 1394).	<ul style="list-style-type: none"> <li>• Check setups.</li> <li>• Run auto tune.</li> </ul>
<b>You cannot obtain the motor acceleration/deceleration that you want</b>	Torque Limit parameters are set too low.	Verify that current limits are set properly.
	Motor Select parameter is incorrectly set.	Program the correct motor and run auto tune again.
	The system inertia is excessive.	<ul style="list-style-type: none"> <li>• Check motor size vs. application need.</li> <li>• Review servo system sizing.</li> </ul>
	The system friction torque is excessive.	Check motor size vs. application need.
	Available current is insufficient to supply the correct accel/decel rate.	<ul style="list-style-type: none"> <li>• Check motor size vs. application need.</li> <li>• Review servo system sizing.</li> </ul>
	Acceleration parameter is incorrect.	Verify parameter settings and correct them, as necessary.
	Velocity Limit parameters are incorrect.	Verify parameter settings and correct them, as necessary.
<b>Motor does not respond to a Velocity Command</b>	Check for possible faults.	Verify parameter settings and correct them, as necessary.
	The axis cannot be enabled for 1.5 seconds after disabling.	Disable the axis, wait for 1.5 seconds, and enable the axis.
	Enable signal has not been applied or the enable wiring is incorrect.	<ul style="list-style-type: none"> <li>• Check the controller.</li> <li>• Check the wiring.</li> </ul>
	The motor wiring is open.	Check the wiring.
	The motor thermal overload has tripped.	<ul style="list-style-type: none"> <li>• Check for a fault.</li> <li>• Check the wiring.</li> </ul>
	The motor has malfunctioned.	Repair or replace the motor.
	The coupling between motor and machine has broken (i.e., the motor moves, but the load/machine doesn't).	Check and correct the mechanics.
	Primary operation mode is set incorrectly.	Check and properly set the parameter.
	Velocity limit parameters are set incorrectly.	Check and properly set the parameter(s).
	The axis module has a malfunction.	Replace the axis module.



Condition:	Potential Cause is:	Possible Resolution is:
<b>Presence of noise on Command or resolver signal wires</b>	Recommended grounding per installation instructions and <i>Appendix A</i> has not been followed.	<ul style="list-style-type: none"> <li>• Verify grounding.</li> <li>• Route wire away from noise sources.</li> </ul>
	External 50/60 Hz line frequency may be present.	<ul style="list-style-type: none"> <li>• Verify grounding.</li> <li>• Route wire away from noise sources.</li> </ul>
	External 100/120 Hz from a single phase logic supply may be present.	<ul style="list-style-type: none"> <li>• Verify grounding.</li> <li>• Route wire away from noise sources.</li> </ul>
	External 180 or 360 Hz from other adjustable speed drives may be present.	<ul style="list-style-type: none"> <li>• Verify grounding.</li> <li>• Route wire away from noise sources.</li> </ul>
	Variable frequency may be velocity feedback ripple or a disturbance caused by gear teeth or ballscrew balls etc. The frequency may be a multiple of the motor power transmission components or ballscrew speeds resulting in velocity disturbance.	<ul style="list-style-type: none"> <li>• Decouple the motor for verification.</li> <li>• Check and improve mechanical performance of the gearbox, ballscrew, etc.</li> </ul>
<b>No Rotation</b>	The motor connections are loose or open.	Check motor wiring and connections.
	Foreign matter is lodged in the motor.	Remove foreign matter.
	The motor load is excessive.	Size the servo system.
	The bearings are worn.	Return the motor for repair.
	The motor brake is engaged (if supplied).	<ul style="list-style-type: none"> <li>• Check brake wiring and function.</li> <li>• Return the motor for repair.</li> </ul>
	The motor is not connect to the load.	Check coupling.
<b>Overheating</b>	The duty cycle is excessive.	Change the command profile to reduce accel/ decel or increase time.
	The rotor is partially demagnetized causing excessive motor current.	Return the motor for repair.
<b>Abnormal Noise</b>	Motor tuning parameters are set too high.	Run auto tune again.
	Loose parts are present in the motor.	<ul style="list-style-type: none"> <li>• Return motor for repair.</li> <li>• Replace motor.</li> </ul>
	Mounting bolts are loose.	Tighten bolts.
	Shaft key loose.	Check coupling.
	The bearings are worn.	Return motor for repair.
<b>Erratic Operation - Motor locks into position, runs without control or with reduced torque</b>	Phases U1 and V1, U1 and W1 or V1 and W1 reversed.	Check and correct motor power wiring.
	Sine, Cosine or Rotor leads are reversed in the feedback cable connector.	Check and correct motor feedback wiring.
	Sine, Cosine, Rotor lead sets of resolver feedback are reversed.	Check and correct motor feedback wiring.

## Understanding Logix/Drive Fault Behavior

This section provides the drive fault actions and indicates whether the fault action is programmable.

The following drive fault action definitions apply:

Drive Fault Action	Definition
Shutdown	The drive disables and the contactor enable relay opens. Uncontrolled stop, motor coasts to a stop.
Disable Drive	The drive is disabled. Uncontrolled Stop, motor coasts to a stop.
Stop Motion	The drive switches internally to velocity mode and sets the command to 0. Logix configuration for velocity loop Kp/Ki is followed. When zero speed is reached or stopping time is exceeded, the drive is disabled. Note: Stopping time and stopping torque are configurable parameters in RSLogix 5000.
Status Only	Drive continues to operate. Status is provided by System Module Status LED and SCANport/DPI (if used).

## System Module Faults

Fault Message RSLogix (HIM):	Description:	Drive Fault Action	RSLogix Programmable Fault Action?
<b>DriveOvercurrent Fault</b> (Bus Overcurrent)	System module exceeded current rating.	SHUTDOWN	No
<b>DriveOvervoltage Fault</b> (Bus Overvoltage)	The DC bus voltage is above limits. If it exceeds (830V dc), a fault is sensed and the power supply is disabled.	SHUTDOWN	No
<b>DriveUndervoltage Fault</b> (Bus Precharge)	The system module pre-charge cycle has failed.	SHUTDOWN	No
<b>DriveUndervoltage Fault</b> (Bus Undervoltage)	The DC power bus activates undervoltage limit when the bus drops to 275V dc or less. It will clear at 300V dc.	SHUTDOWN	No
<b>DriveHardFault</b> (Can Init)	SCANport hardware initialization fault detected.	SHUTDOWN	No
<b>DriveHardFault</b> (Contactor Fault)	Three-phase power is either detected when it shouldn't be or not detected when it should be.	SHUTDOWN	No
<b>MotFeedbackFault</b> (Fdbk Watch Dog)	A feedback hardware or software fault detected.	DISABLE	No
<b>GroundShortFault</b> (Ground Short)	Excessive ground current in the system module was detected.	SHUTDOWN	No
<b>DriveHardFault</b> (IDMA Load)	Motor feedback hardware initialization fault detected.	SHUTDOWN	No

<b>Fault Message RSLogix (HIM):</b>	<b>Description:</b>	<b>Drive Fault Action</b>	<b>RSLogix Programmable Fault Action?</b>
<b>DriveHardFault</b> (Memory Init)	Memory hardware initialization fault detected.	SHUTDOWN	No
<b>DriveHardFault</b> (NV Mem Init)	Non-volatile memory is corrupt.	SHUTDOWN	No
<b>DriveHardFault</b> (Objects Init)	Non-volatile memory is corrupt.	SHUTDOWN	No
<b>PowerPhaseLoss Fault</b> (Phase Loss Flt <sup>2</sup> )	The three-phase input line is monitored and a fault will be issued whenever a phase loss is detected.	SHUTDOWN/ STOP	No
<b>DriveHardFault</b> (SCANport Comm)	SCANport/DPI Communication Failed	STOP	No
<b>SERCOSFault</b> (SERCOS Ring Flt)	SERCOS ring not active after being active and operational.	STOP	No
<b>DriveHardFault</b> (SERCOS Init)	SERCOS hardware initialization fault detected.	SHUTDOWN	No
<b>DriveHardFault</b> (Serial Ring Init)	Intermodule serial communication failed.	SHUTDOWN	No
<b>SERCOSFault</b> (SERCOS Same Addr)	Duplicate node address detected on SERCOS ring.	STOP	No
<b>DriveOvervoltage Fault</b> (Shunt Time Out)	Shunt resistor continuous rating exceeded.	SHUTDOWN	No
<b>DriveOvertemp Fault</b> (Sys Overtemp)	The 1394 thermal sensor tripped when internal ambient temperature exceeded rating.	SHUTDOWN	No
<b>DriveHardFault</b> (Sys Mod Unknown)	Active when serial ring detects unknown system module.	SHUTDOWN	No
<b>DriveHardFault</b> (Task Init)	Software initialization fault detected.	SHUTDOWN	No
<b>DriveHardFault</b> (Unknown Fault)	Fault is detected but source is unknown	STOP	No

## Axis Module Faults

<b>Fault Message RSLogix (HIM):</b>	<b>Description:</b>	<b>Drive Fault Action</b>	<b>RSLogix Programmable Fault Action?</b>
<b>No Fault Message (condition indicated by on-screen message)</b> (Ax: ATune Flt)	Auto tune procedure failed to complete successfully.	DISABLE	No
<b>No Fault Message (condition indicated by on-screen message)</b> (Axis x Hookup Fault)	Hookup procedure failed to complete successfully.	DISABLE	No
<b>DriveHardFault</b> (Axis x Unknown)	Active when serial ring detects unknown axis module.	SHUTDOWN	No
<b>AuxFeedbackFault</b> (Ax: Aux Fdbk AQB)	Auxiliary encoder has encountered an illegal state transition.	DISABLE	No
<b>AuxFeedbackFault</b> (Ax: Aux Fdbk Comm)	Drive unable to communicate with auxiliary Smart feedback device.	STOP	No
<b>AuxFeedbackFault</b> (Ax: Aux Fdbk Loss)	The feedback wiring is open, shorted, or missing.	DISABLE	No
<b>AuxFeedback NoiseFault</b> (Ax: Aux Fdbk Noise)	Excessive noise detected on feedback signals.	DISABLE	Yes
<b>DriveUndervoltage Fault</b> (Ax: Bus Loss)	The DC bus supply to the axis module was lost.	SHUTDOWN	No
<b>DriveOvercurrent Fault</b> (Ax: Desat)	Too much current in the axis module.	STOP	No
<b>DriveEnableInput Fault</b> (Ax: Drive Enable Flt)	Missing Drive Enable Input Signal	STOP	Yes
<b>PositionErrorFault</b> (Ax: Follow Error)	Axis position error limit has been exceeded. This fault can be configured for status only.	DISABLE	Yes
<b>DriveOvercurrent Fault</b> (Ax: I(t) Fault)	The output current is exceeding the time-current rating.	SHUTDOWN	No
<b>SoftOvertravel Fault</b> (Ax: ±Soft Ovrtrvl)	Axis position exceeded maximum software positive/negative travel limit. This fault can be configured for status only.	STOP	Yes

<b>Fault Message RSLogix (HIM):</b>	<b>Description:</b>	<b>Drive Fault Action</b>	<b>RSLogix Programmable Fault Action?</b>
<b>HardOvertravel Fault</b> (Ax: ±Hard Ovrtrvl)	Axis moved beyond the physical travel limits in the positive/negative direction. This fault can be configured for status only.	STOP	Yes
<b>MotFeedbackFault</b> (Ax: Mtr Fdbk AQB)	Motor encoder has encountered an illegal state transition.	DISABLE	No
<b>MotFeedbackFault</b> (Ax: Mtr Fdbk Comm)	Communication was not established with an intelligent (i.e. Stegmann) encoder.	STOP	No
<b>MotFeedbackFault</b> (Ax: Mtr Fdbk Loss)	The feedback wiring is open, shorted, or missing.	DISABLE	No
<b>MotFeedback NoiseFault</b> (Ax: Mtr Fdbk Noise)	Excessive noise detected on feedback signals.	DISABLE	Yes
<b>MotorOvertemp Fault</b> (Ax: Motor x Overtemp)	The motor thermal switch was tripped.	STOP	Yes
<b>OverSpeedFault</b> (Ax: Overspeed)	Motor velocity exceeded the overspeed trip limit.	DISABLE	No
<b>DriveOvertemp Fault</b> (Ax: Overtemp)	Axis module temperature limit exceeded	DISABLE	Yes
<b>DriveOvercurrent Fault</b> (Ax: Power Fault)	The current through any one of the power IGBTs has exceeded 300% of the 1394's current rating.	SHUTDOWN	No

## Supplemental Troubleshooting Information

This section provides information for accessing and changing parameters not accessible through RSLogix 5000 software.

### Tools for Changing Parameters

Most parameters are accessible through RSLogix 5000 software. Alternatives to RSLogix 5000 software for changing parameters include the Human Interface Module (HIM) and DriveExplorer software. Refer to the table below for catalog numbers.

Method:	Description:	Catalog Numbers:	Firmware Revision:
DriveExplorer	DriveExplorer Software <sup>1</sup>	9306-4EXP02ENE	2.01 or later
	Serial to SCANport Adapter	1203-SSS (Series B)	3.004 or later
HIM (series B required)	Programmer Only	1201-HAP	N/A
	Analog Speed Potentiometer	1201-HA1	N/A
	Digital Up-Down Speed Control	1201-HA2	N/A

<sup>1</sup> Refer to *DriveExplorer Getting Results Manual* (publication 9306-GR001x-EN-E) for instructions.

### Changing Parameters Using DriveExplorer

To navigate using DriveExplorer, refer to the figure below. In this example, the I/O Interface group folder is open, the Analog Outputs parameter is selected, and the parameter elements are displayed in the box to the right.

**Figure 2.1**  
**DriveExplorer Example**

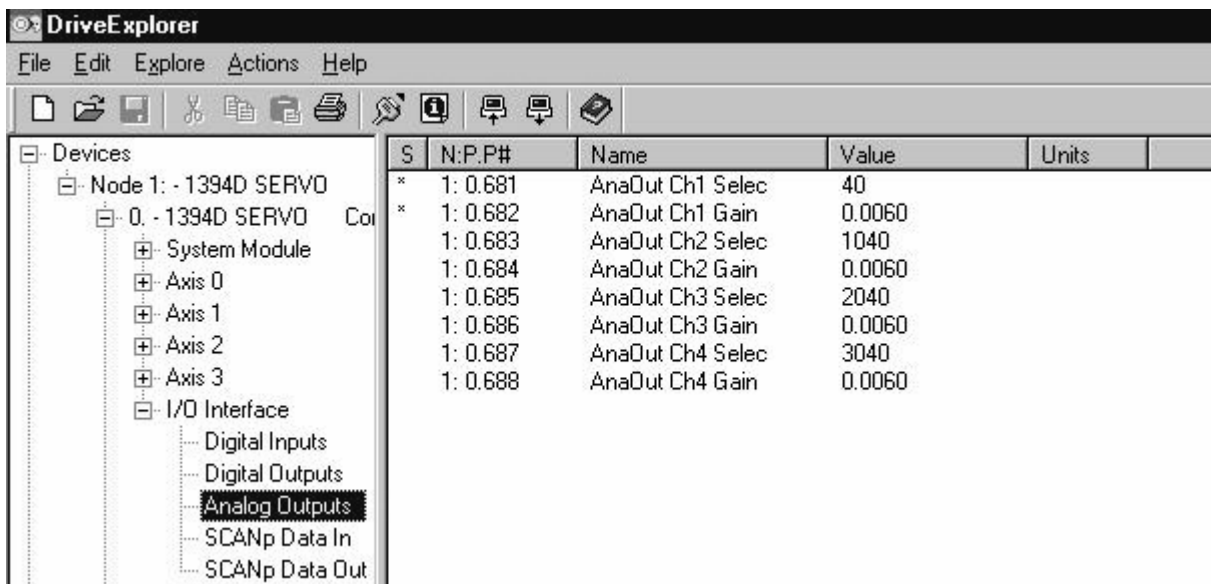

## Changing Parameters Using the HIM

To navigate using the HIM, refer to the programming flowchart in the figure below.

**Figure 2.2**  
**HIM Programming Flowchart**

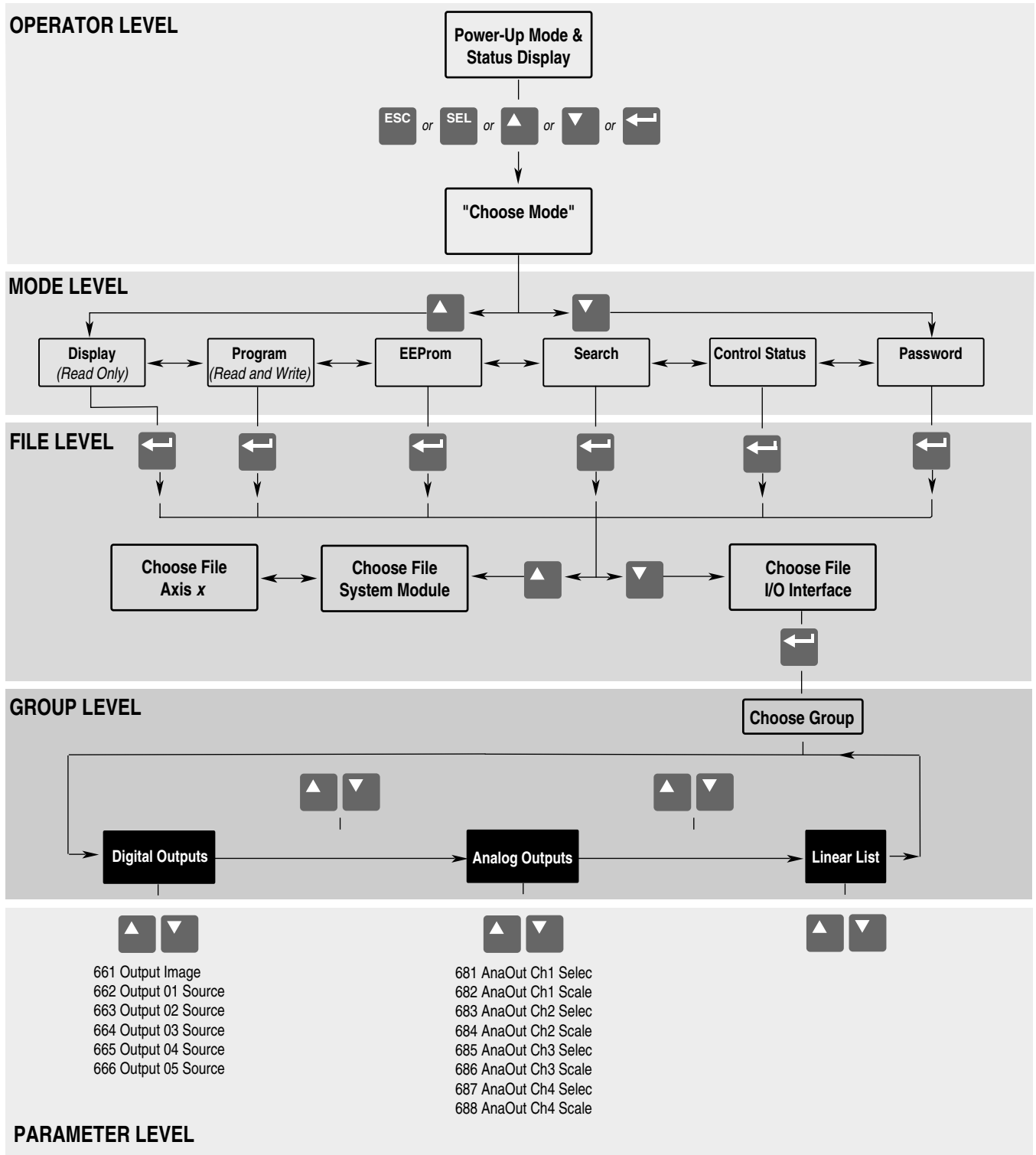

## Using Analog Test Points to Monitor System Variables

There are four analog output test points accessible from the connector on the front of the system module (refer to the figure below for the connector location).

**Figure 2.3**  
**Analog and Relay Output Connectors**

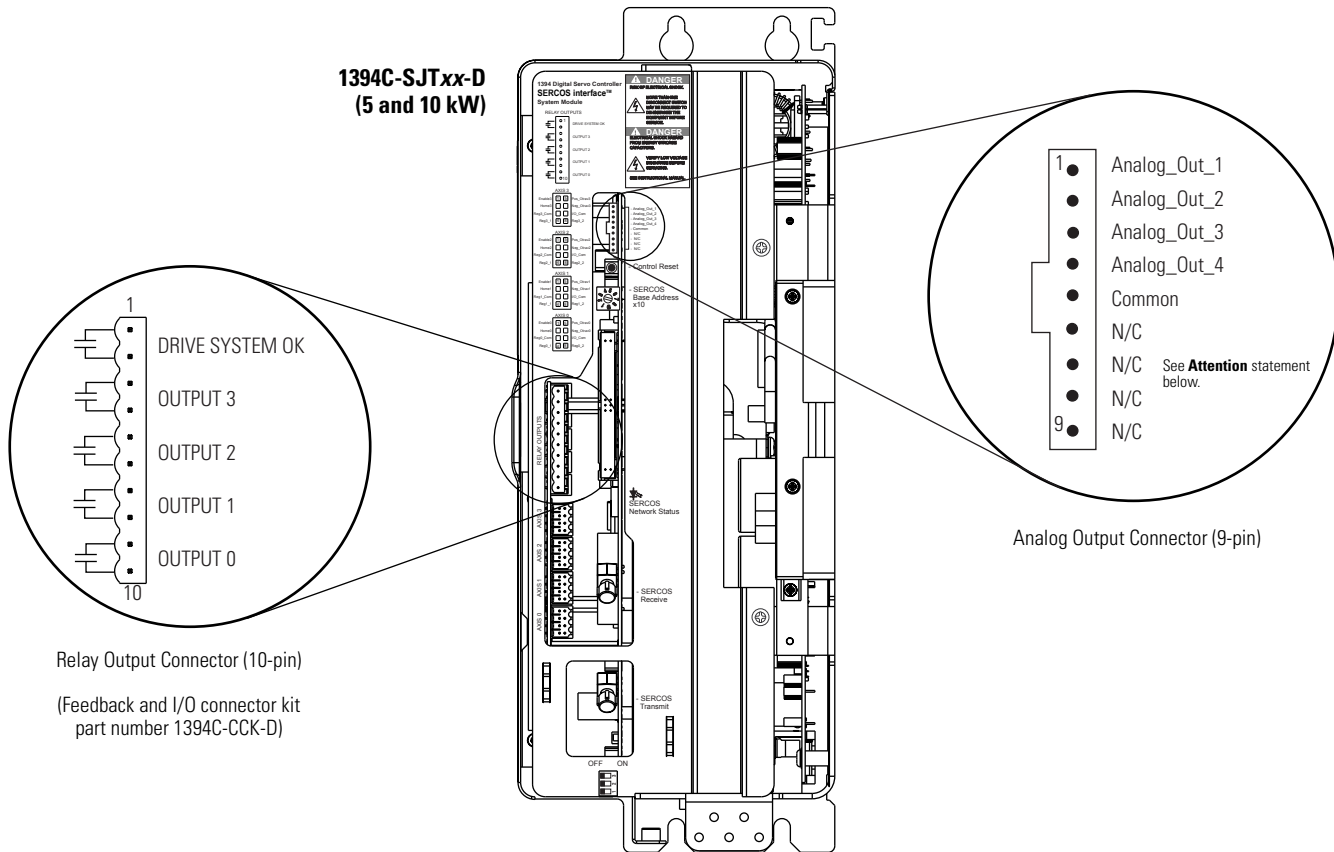

---

**ATTENTION** To avoid damage to the system, do not short the unused pins (6-9) on the Analog Output connector (shown above) together or to ground.



---



To use the four analog output test points to monitor system variables, refer to the table below.

<b>Analog Output:</b>	<b>Controlling Parameter Number:</b>	<b>Default Parameter Number:</b>	<b>Scale Parameter:</b>
1	681	40	682
2	683	1040	684
3	685	2040	686
4	687	3040	688

The value entered in Scale Parameter will scale the analog output so that you can get a full scale reading of the specific parameter for the dynamic range or values you are testing.

To monitor dynamic system variables on analog outputs, use the values shown in the table below.

<b>Attribute:</b>	<b>Parameter Number (axis 0):</b>	<b>Parameter Number (axis 1):</b>	<b>Parameter Number (axis 2):</b>	<b>Parameter Number (axis 3):</b>
Velocity Feedback <sup>1</sup>	40	1040	2040	3040
Velocity Commanded <sup>1</sup>	36	1036	2036	3036
Torque Feedback <sup>2</sup>	84	1084	2084	3084
Torque Commanded <sup>2</sup>	80	1080	2080	3080
Following Error <sup>3</sup>	189	1189	2189	3189

<sup>1</sup> Velocity Command and Feedback scaling value is 1V = 1000 rpm (using default scaling).

<sup>2</sup> Torque Command and Feedback scaling value is 1V = 100% rated motor current or amplifier rating (whichever is less) using default scaling.

<sup>3</sup> Output scaling is dependant on feedback device and drive resolution.

## Changing Default Digital Output Settings

Change the system module parameters listed below by using either the HIM or DriveExplorer software. To locate the relay output connector, refer to Figure 2.3.

Digital Output Number:	HIM Display:	Controlling Parameter:	Default Parameter Number:	Default Parameter Description:	Delay Parameter (on/off):
Drive System OK	Output01 Source	662	617	Drive System OK	
Output 0	Output02 Source	663	528	Axis 0 brake control	206 <sup>1</sup> /207 <sup>2</sup>
Output 1	Output03 Source	664	1528	Axis 1 brake control	1206 <sup>1</sup> /1207 <sup>2</sup>
Output 2	Output04 Source	665	2528	Axis 2 brake control	2206 <sup>1</sup> /2207 <sup>2</sup>
Output 3	Output05 Source	666	3528	Axis 3 brake control	3206 <sup>1</sup> /3207 <sup>2</sup>

<sup>1</sup> When the axis is enabled, there is a delay (ms) (Drive On Delay) between the axis having torque commanded (brake releasing) and the axis following reference.

<sup>2</sup> When the axis is disabled, there is a delay (ms) (Drive Off Delay) between the axis reaching zero speed or the stopping time (brake engaging), and torque removed.

To monitor dynamic system variables on digital outputs, use the values shown in the table below.

Attribute:	Parameter Number			
	Axis 0 Parameter (Threshold Setting Parameter)	Axis 1 Parameter (Threshold Setting Parameter)	Axis 2 Parameter (Threshold Setting Parameter)	Axis 3 Parameter (Threshold Setting Parameter)
At Zero Speed	331 (124)	1331 (1124)	2331 (2124)	3331 (3124)
At Programmed Speed	330 (157)	1330 (1157)	2330 (2157)	3330 (3157)
Velocity Command Above Limit	335 (38+) (39-)	1335 (1038+) (1039-)	2335 (2038+) (2039-)	3335 (3038+) (3039-)
Velocity Below Limit	332 (125)	1332 (1125)	2332 (2125)	3332 (3125)
Torque Above Limit	334 (82+) (83-)	1334 (1082+) (1083-)	2334 (2082+) (2083-)	3334 (3082+) (3083-)
Torque Above Threshold	333 (126)	1333 (1126)	2333 (2126)	3333 (3126)
In Position	336 (57)	1336 (1057)	2336 (2057)	3336 (3057)

## Replacing System and Axis Modules

Use these procedures to:

- Determine what you need to replace modules
- Remove an axis module
- Install a replacement axis module
- Remove a system module
- Install a replacement system module

Note: If you are replacing the fuse in 1394-SRxxxx shunt modules refer to *1394 Shunt Modules Fuse Replacement Kit Installation Instructions* (publication 1394-6.6).

Note: If you are replacing the cooling fan in the 1394x-AM50 or -AM75 axis modules refer to *Replacing the 10 and 15 kW Axis Module Fan Installation Instructions* (publication 1394-5.15).

---

### ATTENTION



This drive contains ESD (Electrostatic Discharge) sensitive parts and assemblies. You are required to follow static control precautions when you install, test, service, or repair this assembly. If you do not follow ESD control procedures, components can be damaged. If you are not familiar with static control procedures, refer to Allen-Bradley publication 8000-4.5.2, *Guarding Against Electrostatic Damage* or any other applicable ESD Protection Handbook.

---

## Before You Begin

Before you replace modules, be sure to have the following:

- A phillips screw driver
- A standard screw driver
- A voltmeter
- A nutdriver
- A wrench

## Removing an Axis Module

To remove an axis module:

1. Remove 24V control power and main input power from the system.

---

**ATTENTION**

To avoid shock hazard or personal injury, assure that all power has been removed before proceeding. This system may have multiple sources of power. More than one disconnect switch may be required to de-energize the system.

---

2. Allow five minutes for the DC bus to completely discharge before proceeding.

---

**ATTENTION**

To avoid hazard of electrical shock, verify that all voltage on the capacitors has been discharged before attempting to service, repair, or remove this unit. This product contains stored energy devices. You should only attempt the procedures in this document if you are qualified to do so and familiar with solid-state control equipment and the safety procedures in publication NFPA 70E.

---

3. Remove connectors (TB1 and TB2) from the bottom of the axis module.
4. Label and remove the motor leads and ground wiring from the terminal block on the axis module.
5. Disconnect the slide-and-lock mechanism on the module you plan to remove and all modules to the right of it.
6. Remove the bottom fastener on the axis module you plan to remove.
7. Loosen the top fastener on the axis module you plan to remove.
8. Lift the axis module and pull it out.
9. If you are removing the right-most axis module, remove the terminator.

## Installing a Replacement Axis Module

To install a replacement axis module:

1. Install the top mounting fastener on the system panel for the axis module. The head of the fastener should be at least 6.35 mm (0.25 in.) from the panel. Refer to the *1394 SERCOS Interface Installation Manual* (publication 1394-IN002x-EN-P) for more information.

2.

If you are mounting:	Do this:
A 1394x-AM03, -AM04, -AM07 -AM50-IH, or -AM75-IH axis module	Go to main step 3.
A 1394x-AM50 or -AM75 axis module with the heat sink through the back of the enclosure	<ol style="list-style-type: none"> <li>1. Remove the paper backing from the gasket that came with the AM50/75 axis module.</li> <li>2. Position the gasket so that the small hole side is on top.</li> <li>3. Slide the gasket over the heat sink and attach it to the back of the axis module.</li> <li>4. Go to main step 3.</li> </ol>

3. Hang the axis module on the next mounting fastener.
4. Engage the alignment tab.
5. Slide the slide-and-lock mechanism on the axis module to the left until it locks into place.
6. Install the lower fastener for all axis modules.
7. If not already attached, attach the terminator to the last axis module slide-and-lock mechanism until it locks in place.
8. Tighten all mounting fasteners.
9. Reconnect TB1, TB2, motor, and ground wires.

**ATTENTION**



If you are replacing a Series B axis module with a Series C axis module you must use 24V dc in the thermal switch circuit to avoid damage to the filter components between TB1 and TB2. Refer to the interconnect diagrams in *Appendix A* for examples.

10. Apply power to the system.
11. Verify that the system is operating properly.

Note: Because system and axis parameters reside in the system module software, you do not need to perform any tuning or setup at this time.

## Removing a System Module

To remove a system module:

1. Remove the main input power from the system.

---

**ATTENTION**

To avoid shock hazard or personal injury, assure that all power has been removed before proceeding. This system may have multiple sources of power. More than one disconnect switch may be required to de-energize the system.

---

2. Remove all 24V control input power from the system.
3. Allow five minutes for the DC bus to completely discharge before proceeding.

---

**ATTENTION**

To avoid hazard of electrical shock, verify that all voltage on the capacitors has been discharged before attempting to service, repair, or remove this unit. This product contains stored energy devices. You should only attempt the procedures in this document if you are qualified to do so and familiar with solid-state control equipment and the safety procedures in publication NFPA 70E.

---

4. Label and remove the 24V control power wiring from the system module.
5. Label and remove the main input power wiring from the system module.
6. Label and remove the ground wire and the external shunt connections (if applicable).
7. Label and remove the feedback and communication connectors from the bottom of system module.

8. Disconnect the slide-and-lock mechanism on the system module.
9. Open the system module door.
10. Label and remove any feedback and/or communication connectors from the control board.
11. Loosen the top and bottom fasteners that hold the module in place.
12. Lift the module up and pull it out.

## Installing a Replacement System Module

To install a replacement system module:

1. Install the top mounting fasteners on the system panel for the system module. The heads of the fasteners should be at least 6.35 mm (0.25 in.) from the panel. Refer to the *1394 SERCOS Interface Installation Manual* (publication 1394-IN002x-EN-P) for more information.
2. Hang the 1394 System Module on the two mounting fasteners on the left side of the panel.
3. Install the lower fasteners for the system module.
4. Open the system module door.
5. Connect the slide-and-lock mechanism on the system module to the axis modules.
6. Reconnect feedback and communication connectors to the system module. Refer to *Appendix A* for connection information.
7. Connect the ground wire and if used, the external shunt resistor connections.
8. Connect the 24V control power and main input power to the system module.
9. Connect all shunt wiring (if applicable).
10. Apply 24V control power to the system module.

11. Apply main input power to the system module.

---

**IMPORTANT**

If you are replacing a Series C system module with a Series D system module, you must auto tune each axis to ensure proper operation. Refer to *Testing and Tuning Your Axes* beginning on 1-22 for more information.

---

12. Verify that your system is operating properly.



## **Interconnect Diagrams**

### **Chapter Objectives**

This appendix covers the following:

- Power Interconnect Diagrams
- Shunt Module Interconnect Diagrams
- Axis Module/Motor Interconnect Diagrams
- Understanding Motor Thermal Switches
- Brake Interconnect Diagrams

## 1394 SERCOS Interface Interconnect Diagram Notes

This section provides interconnect diagrams to assist you in wiring the 1394 system. The notes in the table below apply to the interconnect diagrams on the pages that follow.

Note:	Information:
1	For power wiring specifications, refer to the <i>1394 SERCOS Interface Installation Manual</i> (publication 1394-IN002x-EN-P).
2	For input fuse and circuit breaker sizes, refer to the <i>1394 SERCOS Interface Installation Manual</i> (publication 1394-IN002x-EN-P).
3	For AC line filter specifications, refer to the <i>1394 SERCOS Interface Installation Manual</i> (publication 1394-IN002x-EN-P).
4	Contactors coil (M1) needs integrated surge suppressors for AC coil operation.
5	Drive Enable input must be opened when main power is removed, or a drive fault will occur. A delay of at least 1.0 second must be observed before attempting to enable the drive after main power is restored.
6	Cable shield clamp must be used in order to meet CE requirements. No external connection to ground required.
7	Jumper is factory set, indicating grounded system at user site. Ungrounded sites must jumper the bleeder resistor to prevent high electrostatic buildup. Refer to the <i>1394 SERCOS Interface Installation Manual</i> (publication 1394-IN002x-EN-P) for more information.
8	<div style="display: flex; align-items: center;"> <div style="border: 1px solid black; padding: 5px; margin-right: 10px;"> <p style="text-align: center; margin: 0;"><b>ATTENTION</b></p>  </div> <div> <p>Implementation of safety circuits and risk assessment is the responsibility of the machine builder. Please reference international standards EN1050 and EN954 estimation and safety performance categories. For more information refer to <i>Understanding the Machinery Directive</i> (publication SHB-900).</p> </div> </div>
9	The recommended minimum wire size for wiring the safety circuit to the contactor enable connector is 1.5 mm <sup>2</sup> (16 AWG).
10	If an external shunt resistor is used, remove the jumper between INT and COL.
11	There is no internal shunt resistor in the 22 kW system module. An external shunt resistor module (1394-SRx Ax) must be used.
12	The thermal switch and brake circuits are a source of conducted noise. Isolation from customer control devices may be required. A separate 24V dc supply or relay can be used. Axis modules (Series C or later) include a thermal switch and motor brake filter to eliminate the need for a separate 24V dc supply.
13	Use a flyback diode for noise suppression of the motor brake coil. For more information, refer to <i>System Design for Control of Electrical Noise Reference Manual</i> (publication GMC-RM001x-EN-P).
14	For motor cable specifications, refer to <i>Motion Control Selection Guide</i> (publication GMC-SG001x-EN-P).
15	User supplied auxiliary contact is recommended. Use safety rated, mechanically linked contactor for M1.

# Power Interconnect Diagrams

The power interconnect wiring for the 1394 SERCOS interface system module is shown in the figures below.

**Figure A.1**  
1394C-SJT05-D or -SJT10-D Interconnect Diagram

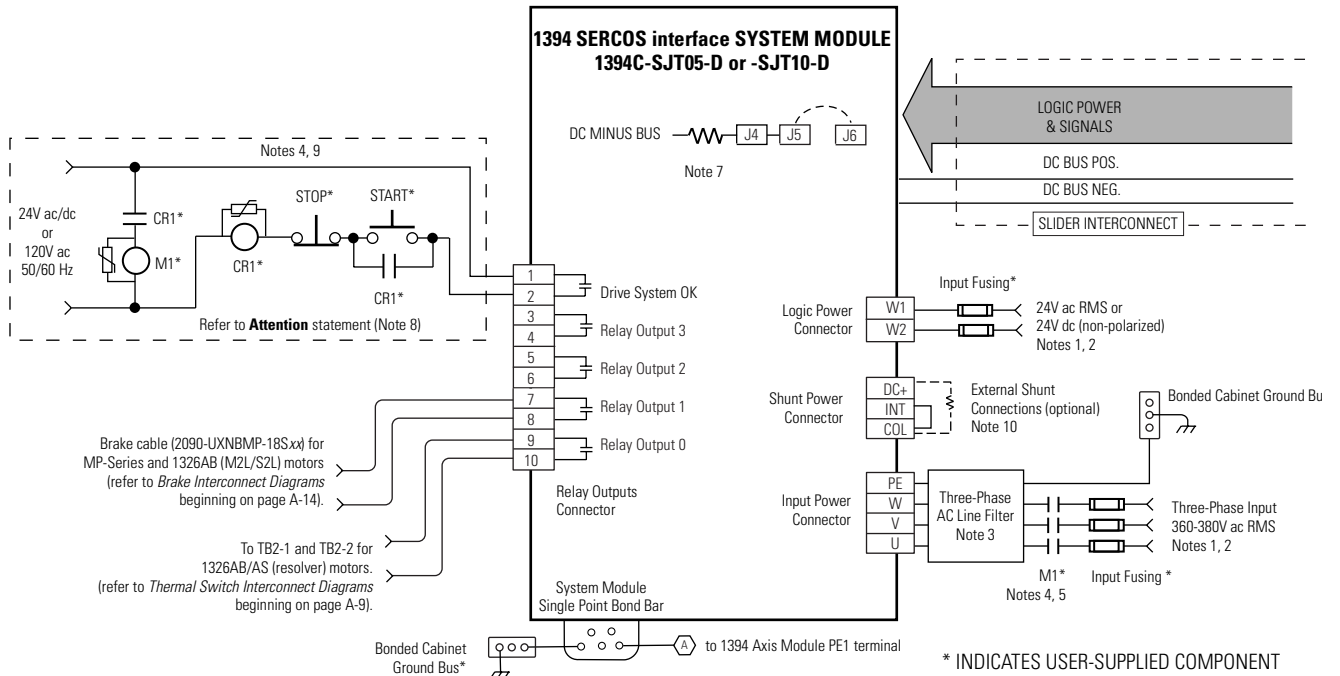

**Figure A.2**  
1394C-SJT22-D Interconnect Diagram

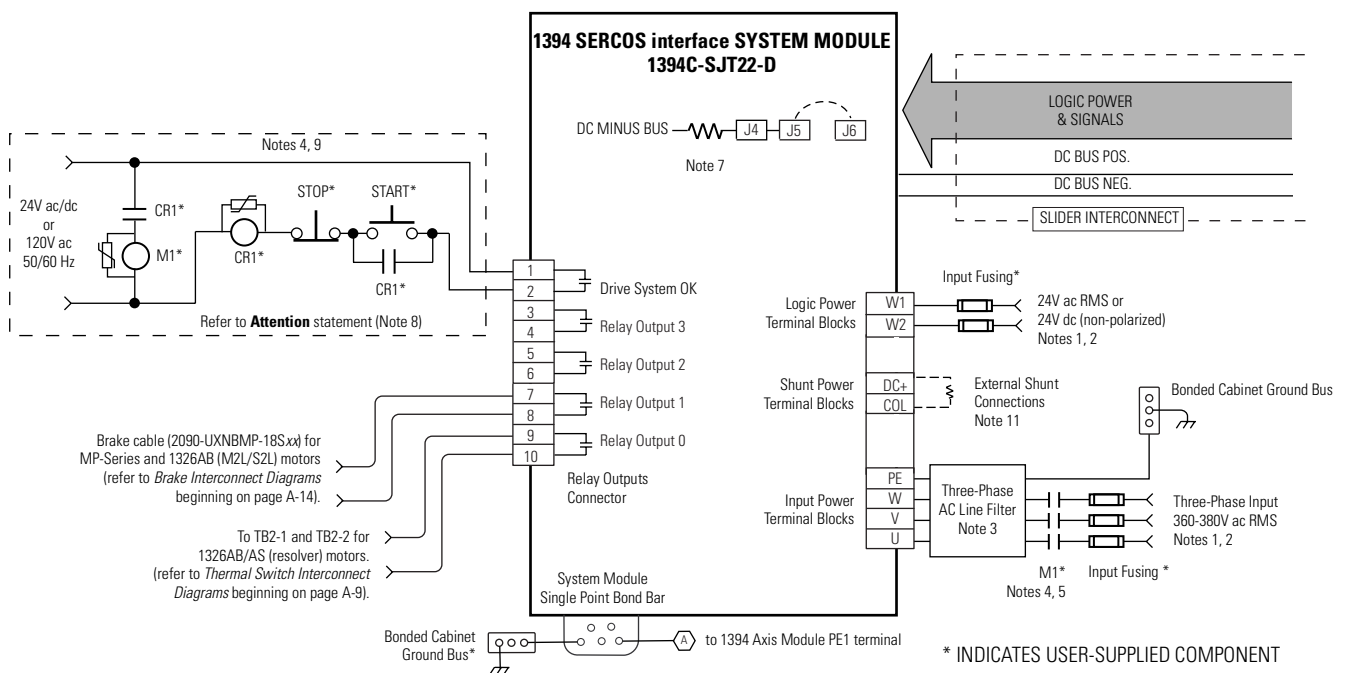

## Shunt Module Interconnect Diagrams

In the figure below, the 1394 system module is shown wired for internal shunt operation. This is the factory default jumper setting.

### IMPORTANT

Internal shunt operation is only present on the 1394 system modules listed in Figure A.3.

**Figure A.3**  
**Internal Shunt Interconnect Diagram**

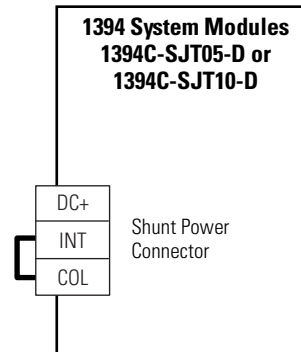

In the figure below, the 1394C-SJT05-D and -SJT10-D system modules are shown wired with the optional external shunt resistor.

**Figure A.4**  
**External Shunt Module Interconnect Diagram (optional)**

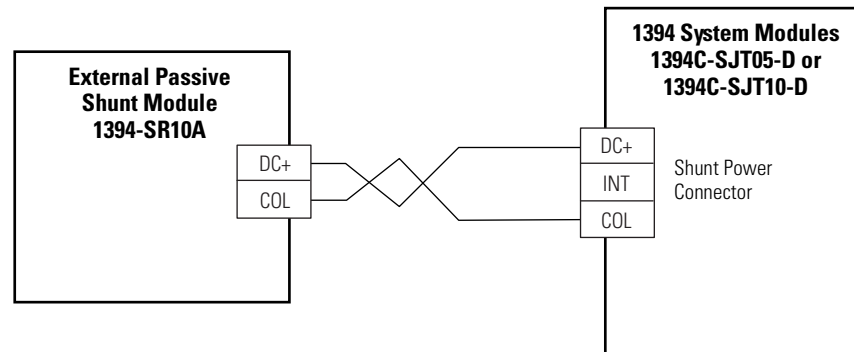

In the figure below, the 1394C-SJT22-D system module is show wired with an external shunt resistor.

**IMPORTANT**

All 1394 configurations with 22 kW system modules require an external shunt module.

**Figure A.5**  
**External Shunt Module Interconnect Diagram (required)**

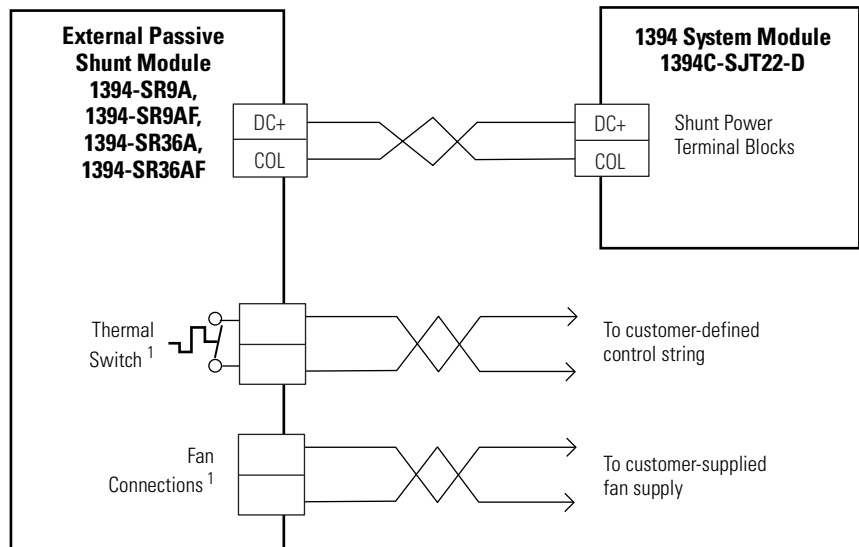

<sup>1</sup> The thermal switch and fan connections are only included with the 1394-SR36A and -SR36AF shunt modules.

# Axis Module/Motor Interconnect Diagrams

This section contains the motor power, brake, and feedback signal interconnect diagrams between an Axis Module and MP-Series, 1326AB, and 1326AS servo motors.

In the figure below, the 1394 axis module is shown connected to MP-Series Low Inertia (460V) motors.

**Figure A.6**  
**Axis Module to MP-Series Low Inertia Motors Interconnect Diagram**

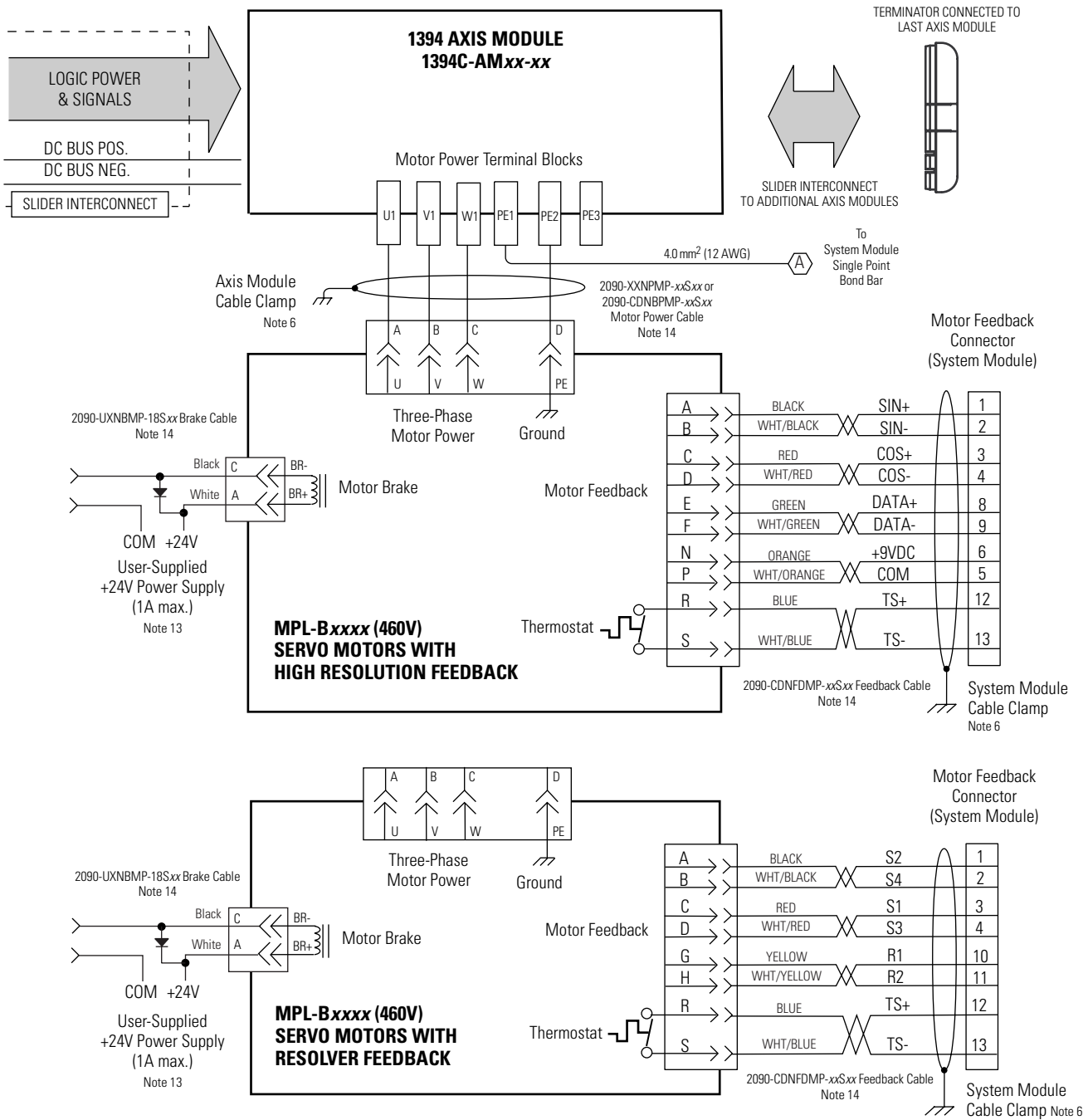

In the figure below, the 1394 axis module is shown connected to 1326AB (460V) servo motors.

**Figure A.7**  
**Axis Module to 1326AB Motors Interconnect Diagram**

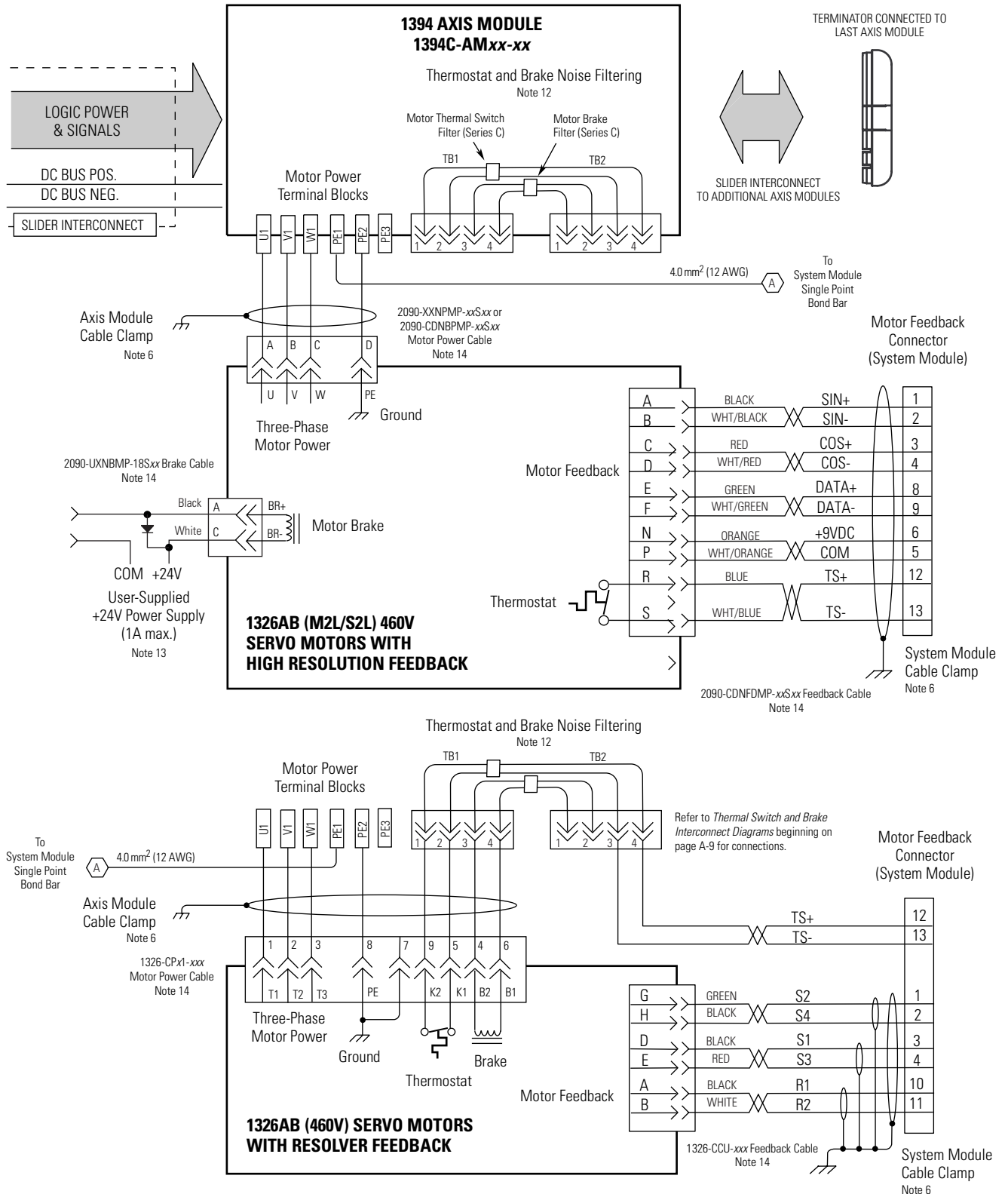

In the figure below, the 1394 axis module is shown connected to 1326AS (460V) servo motors.

**Figure A.8**  
**Axis Module to 1326AS Motors Interconnect Diagram**

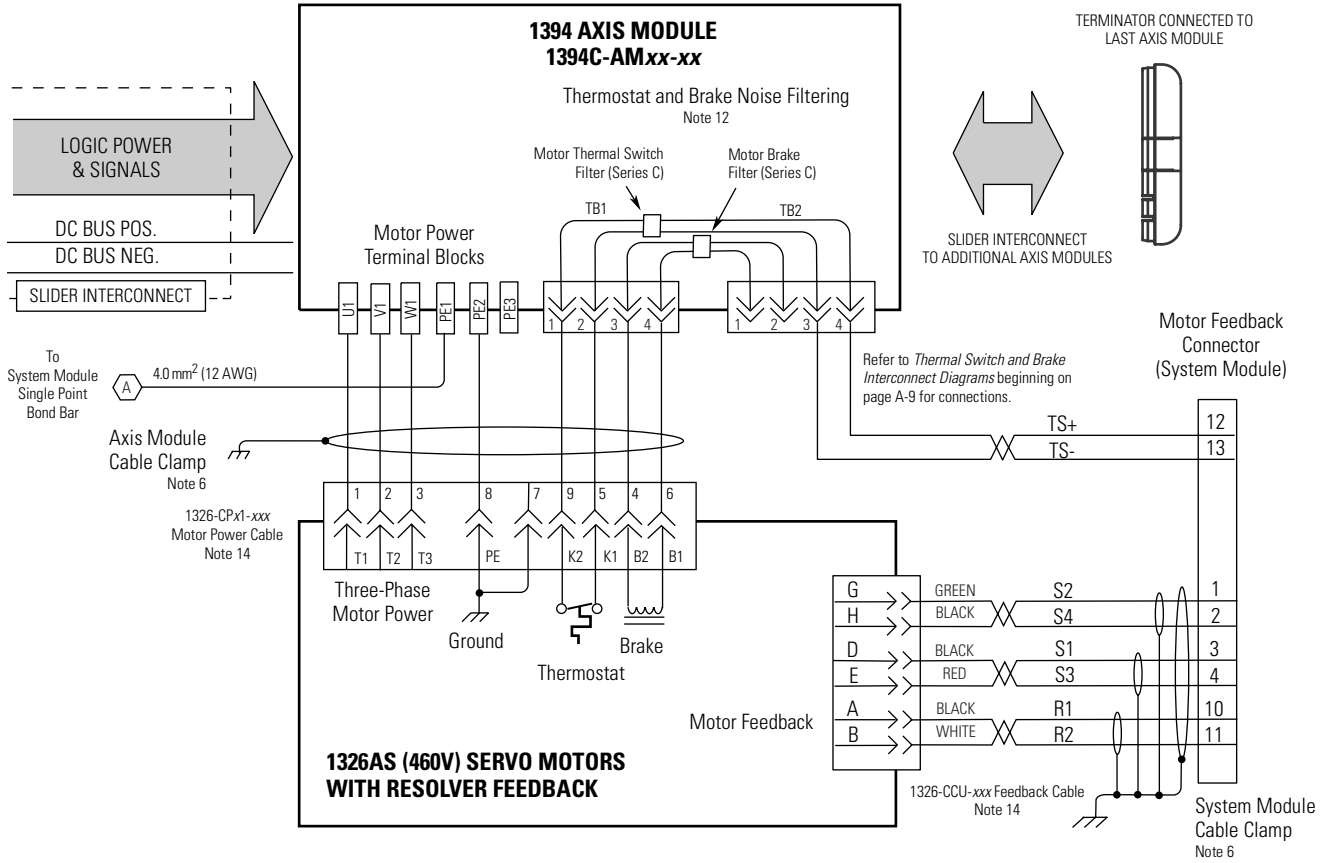



## Thermal Switch and Brake Interconnect Diagrams

This section provides thermal switch and brake interconnect diagrams.

### Understanding Motor Thermal Switches

Thermal switches, internal to each servo motor, can be wired in series to protect the motor from overheating. In the event of a fault condition, the switch opens and the motor responds to the system configuration. The explanation and example diagrams that follow show how to wire motor thermal switches to your system module.

Depending on the series of your 1394 axis module, your customer control devices may require isolation from the motor's conducted noise. When using 1394 (Series A and B) axis modules, an isolated 24V dc power supply and relay is recommended. 1394 (Series C) axis modules contain internal motor brake and thermal switch filtering and do not require the isolation power supply and relay.

Individual thermal fault monitoring can be achieved by wiring each of the motor thermal switches from the motor, through TB1/TB2 on the axis module, or directly from the motor to one of four dedicated thermal fault inputs on the system module. Your 1394 system can then be configured to monitor and disable one or all four of the axes. As an alternative, you can wire the thermal switches into the start/stop string to disable all axes when a fault occurs.

### How Your Feedback Cable Affects Thermal Switch Wiring

The examples shown on the following pages are for 1326AB/AS servo motors with resolver feedback (using 1326-CCU-xxx feedback cables). The motor thermal switch leads are in the motor power cable and attach to TB1 of the axis module (refer to figures A.7 and A.8 for motor/axis module interconnect diagrams).

1326AB (M2L/S2L) motors and MP-Series motors (both resolver and high resolution feedback) use 2090-CDNFDMP-Sxx feedback cables. The motor thermal switch wires are in the motor feedback cable and attach directly to the feedback connector on the bottom of the 1394 system module. Refer to figures A.6 and A.7 for motor/system module interconnect diagrams).

### Thermal Switch Interconnect Diagrams

The example in Figure A.9 shows 1394 (Series C) axis modules with internal brake and thermal switch filtering. Separate isolation power supply and relay are not required. Using this start/stop string configuration all axes are disabled when any one motor faults.

**Figure A.9**  
**Non-Isolated Series Start/Stop String**

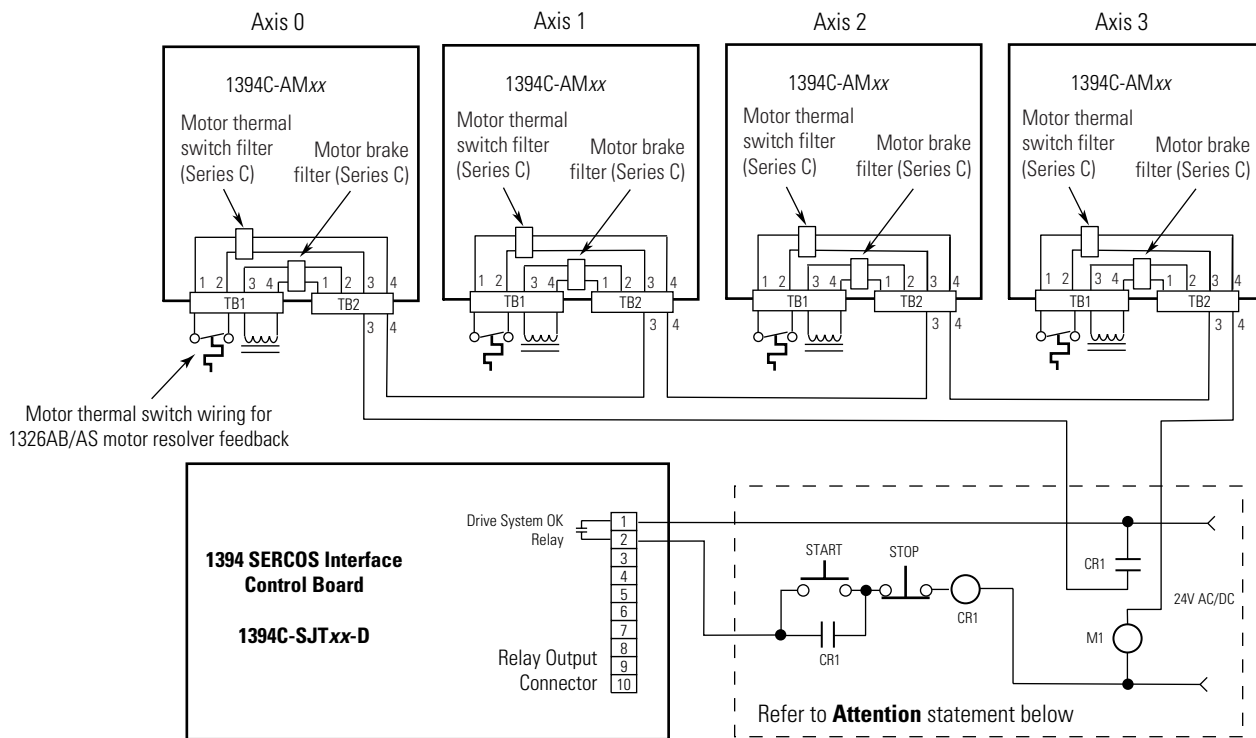

**IMPORTANT**

The thermal circuit includes filtering on the TB1/TB2 connector board that is rated for 24V only. For TB1/TB2 wiring alternatives, refer to the table below.

If:	Then:
120V ac is used on the start/stop string	Option 1: Install a 24V pilot relay on the thermal switch circuit. Option 2: Bypass the TB1/TB2 terminations <sup>1</sup> .
24V is used on the start/stop string	Follow the wiring shown in Figure A.9 above.

<sup>1</sup> When bypassing the TB1/TB2 terminations, ensure that unshielded motor power conductors are kept as short as possible at the drive, as they will radiate high levels of electrical noise.

Note: Refer to Figure 1.3 for the location of the TB1/TB2 connectors and pin-out diagram.

**ATTENTION**



Implementation of safety circuits and risk assessment is the responsibility of the machine builder. Please reference international standards EN1050 and EN954 estimation and safety performance categories. For more information refer to *Understanding the Machinery Directive* (publication SHB-900).

The example below shows 1394 (Series C) axis modules wired for thermal fault monitoring. Depending on how the 1394 system is configured, the fault can be used to disable one or all of the four axis modules.

**Figure A.10**  
**Non-Isolated with Thermal Fault Monitoring**

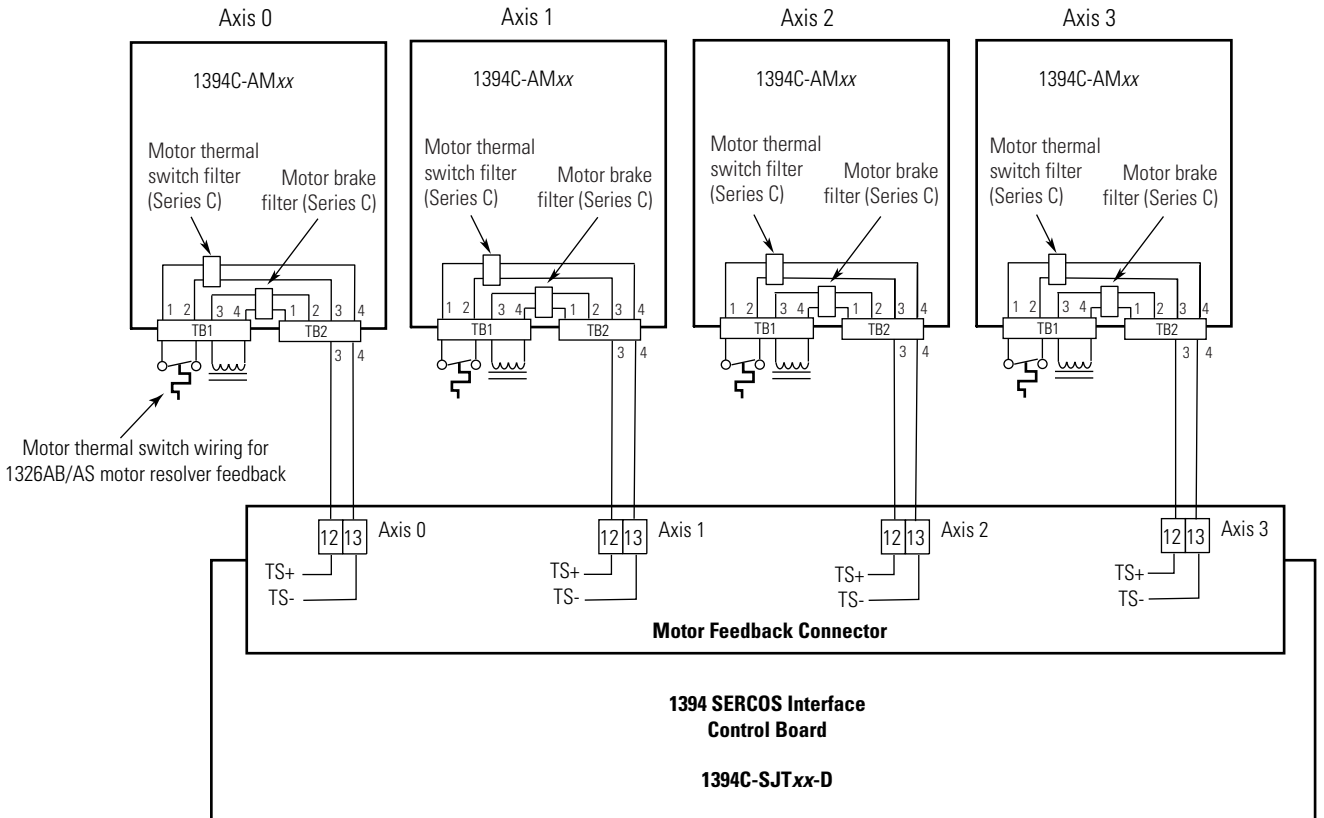

Note: Refer to Figure 1.3 for the location of the TB1/TB2 connectors and pin-out diagram.

The example below shows 1394 (Series A and B) axis modules (no internal brake or thermal switch filter). Separate 24V dc isolation power supply and relay (CR2) are recommended. Using this start/stop string configuration all axes are disabled when any one motor faults.

**Figure A.11**  
**Isolated Series Start/Stop String**

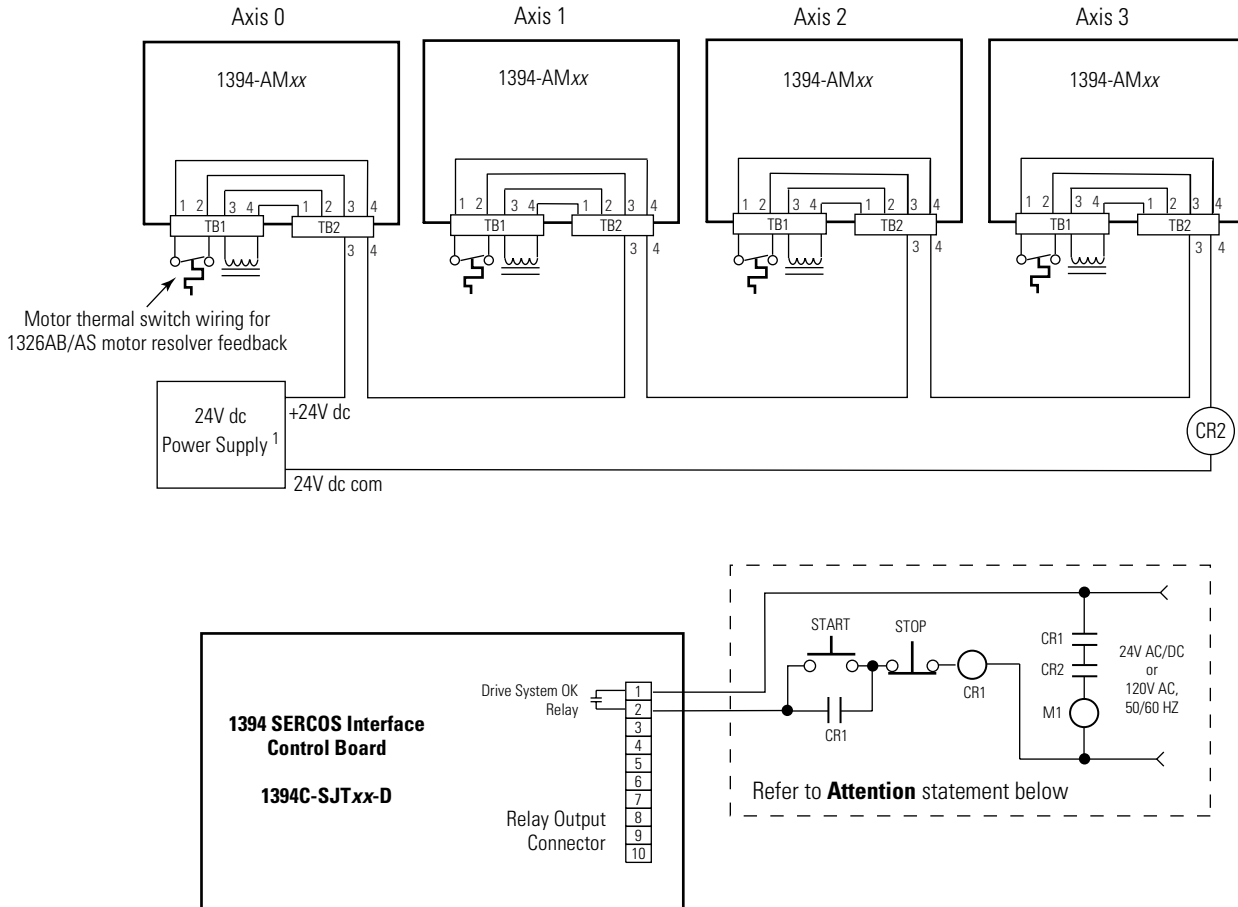

<sup>1</sup> 120V ac (50/60 Hz) power may be used in place of 24V dc for motor thermal switch circuits in Series A and B axis modules.

Note: Refer to Figure 1.3 for the location of the TB1/TB2 connectors and pin-out diagram.

**ATTENTION**



Implementation of safety circuits and risk assessment is the responsibility of the machine builder. Please reference international standards EN1050 and EN954 estimation and safety performance categories. For more information refer to *Understanding the Machinery Directive* (publication SHB-900).

The example below shows 1394 (Series A and B) axis modules wired for thermal fault monitoring. Depending on how the 1394 system is configured, the fault can be used to disable one or all of the four axis modules. Two separate 24V dc power supplies and four relays (CR2-CR5) are included to isolate the thermal inputs from conducted noise.

**Figure A.12**  
**Isolated with Thermal Fault Monitoring**

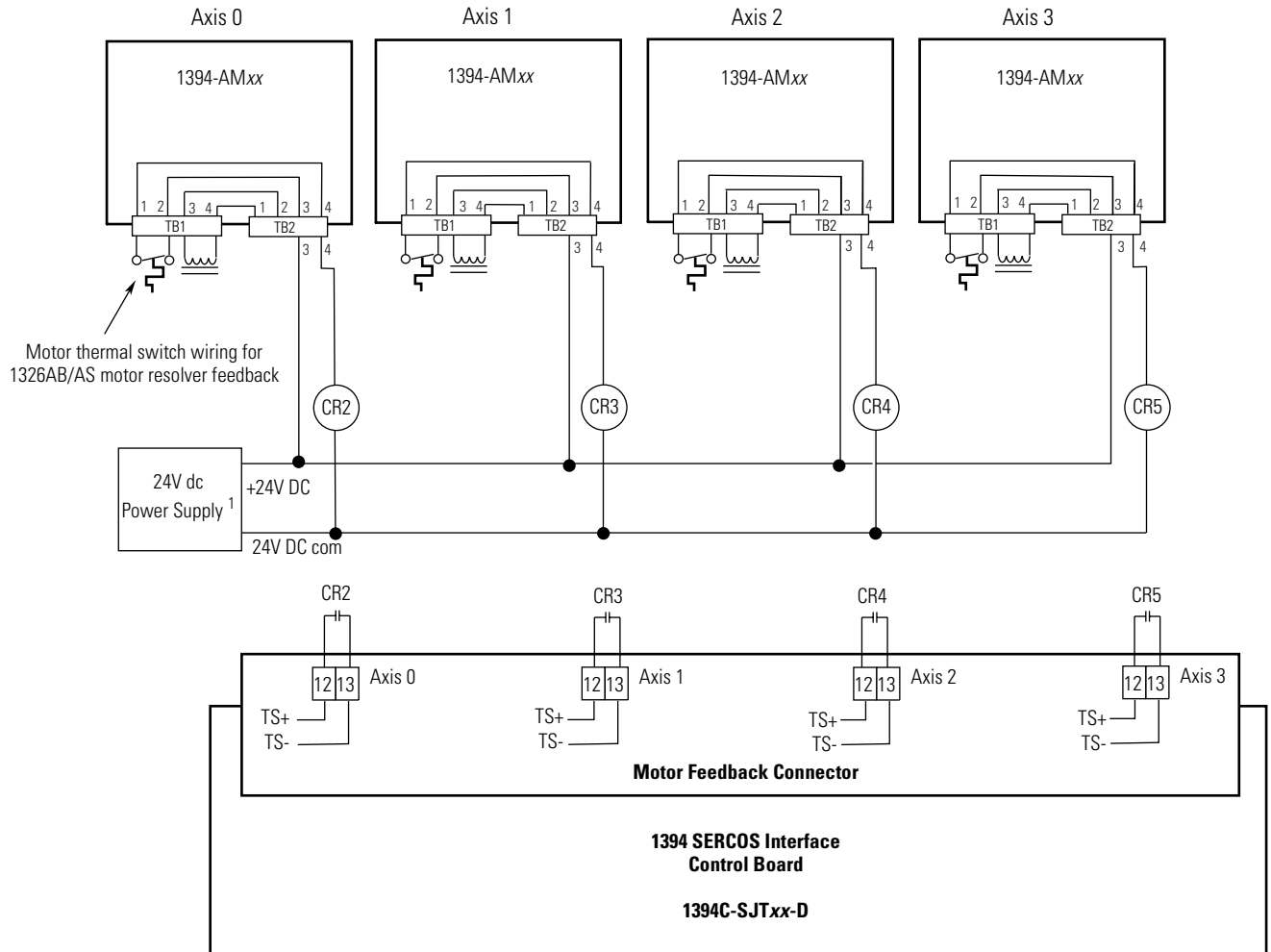

<sup>1</sup> 120V ac (50/60 Hz) power may be used in place of 24V dc for motor thermal switch circuits in Series A and B axis modules.

Note: Refer to Figure 1.3 for the location of the TB1/TB2 connectors and pin-out diagram.

## Brake Interconnect Diagrams

The relay outputs (Output 0-3) are linked to the Brake Enable/Disable configuration in RSLogix 5000 axis properties to allow control of a motor brake for each axis. When an axis is enabled, the configured output relay contact will close to disengage the associated motor brake. At the same time, the axis will command sufficient torque to hold the motor's position while the brake is disengaging. The length of time that the axis will apply this torque is set by the Brake Off Delay parameter for each axis. When an axis is disabled and the motor has reached zero velocity, the configured output relay contact will open to engage the associated motor brake. At the same time, the axis will command sufficient torque to hold the motor's position while the brake is engaging. The length of time that the axis will apply this torque is set by the Brake On Delay parameter for each axis. Refer to *Configuring Axis Properties* beginning on page 1-18 to set delay times in RSLogix 5000.

Depending on the series of your 1394 axis module, your brake circuitry may require isolation from the motor's conducted noise. When using 1394 Series B axis modules, an isolated 24V dc power supply and relay is recommended. 1394 Series C axis modules contain an internal motor brake filter and do not require the isolation power supply and relay. The Series C brake filter also contains a bi-directional snubber diode to protect the user-supplied 24V dc brake power supply.

---

**IMPORTANT**

The output relay contacts are rated to control a 24V dc motor brake rated up to 1A. Motor brakes rated greater than 1A require an additional relay or contactor with sufficient rating to handle the higher current.

---

The example below shows 1394 series C axis modules with internal brake filtering. Each axis is connected to a motor with a brake rated at less than 1A. A separate pilot relay is not required. Motor brakes that do not require a pilot relay are shown in the table below.

Note: Suppression devices and pilot relays impact motor brake response time.

Motor Series:	Brake Option:	Brake Response Time Pickup/Dropout mSec
1326AB-B4	K4	120/20
1326AS-B3	K3	38/10
1326AS-B4	K4	44/13
MPL-B3 (460V)	4	50/20
MPL-B4 (460V)	4	110/25
MPL-B45 (460V)	4	

**Figure A.13**  
**Brake Interconnect Diagram**

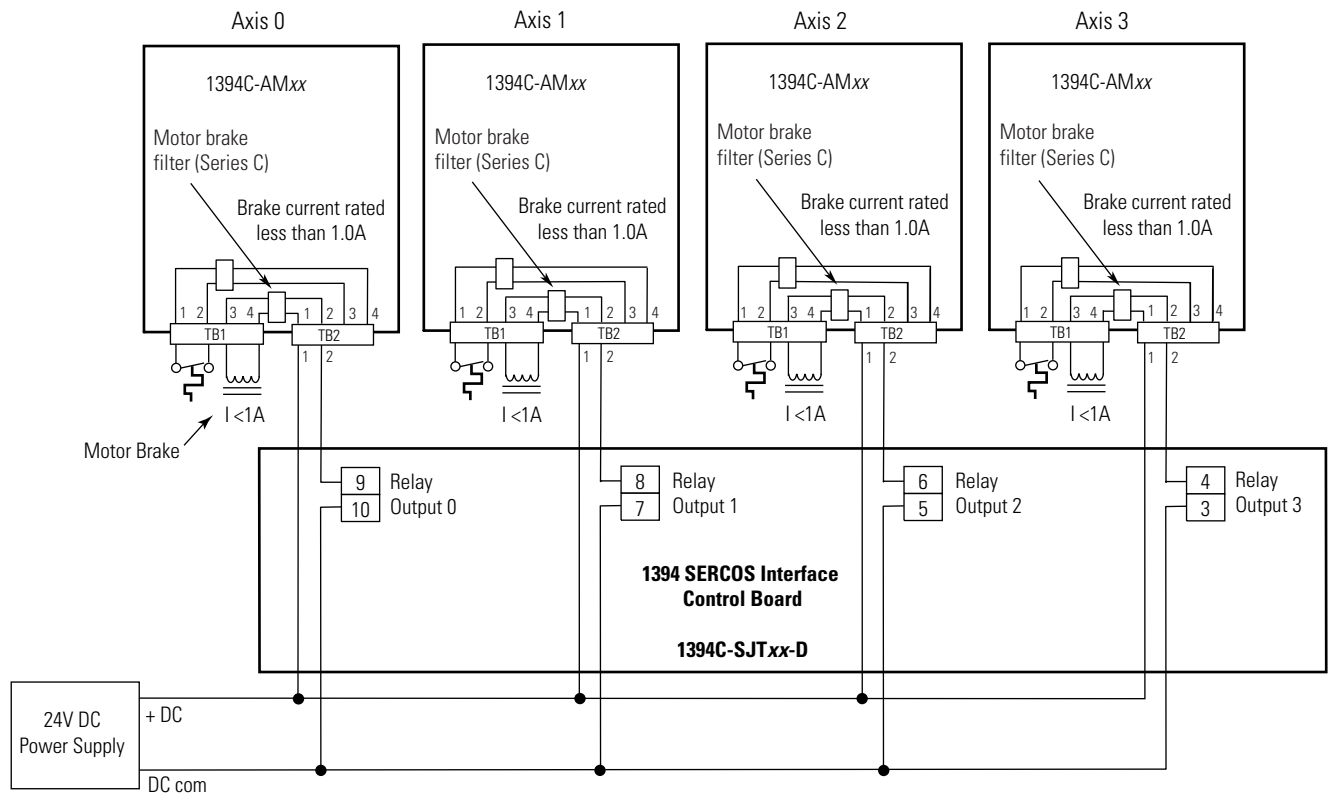

Note: Refer to Figure 1.3 for the location of the TB1/TB2 connectors and pin-out diagram.

Note: Refer to figures 1.1 and 1.2 for the location of the 10-pin relay output connector.

The example below also shows 1394 series C axis modules with internal brake filtering. Each axis is connected to a motor with a brake rated at greater than 1A. A separate pilot relay is required for brake current handling.

Note: Suppression devices and pilot relays impact motor brake response time.

Motor Series:	Brake Option:	Brake Response Time Pickup/Dropout mSec
1326AB-B5	K5	150/25
1326AB-B7	K7	120/30
1326AS-B6	K6	114/11
1326AS-B8	K8	200/12
MPL-B5 (460V)	4	70/50
MPL-B6 (460V)	4	200/120
MPL-B8 (460V)	4	250/200
MPL-B9 (460V)	4	300/200

**Figure A.14**  
**Isolated Brake (with pilot relay) Interconnect Diagram**

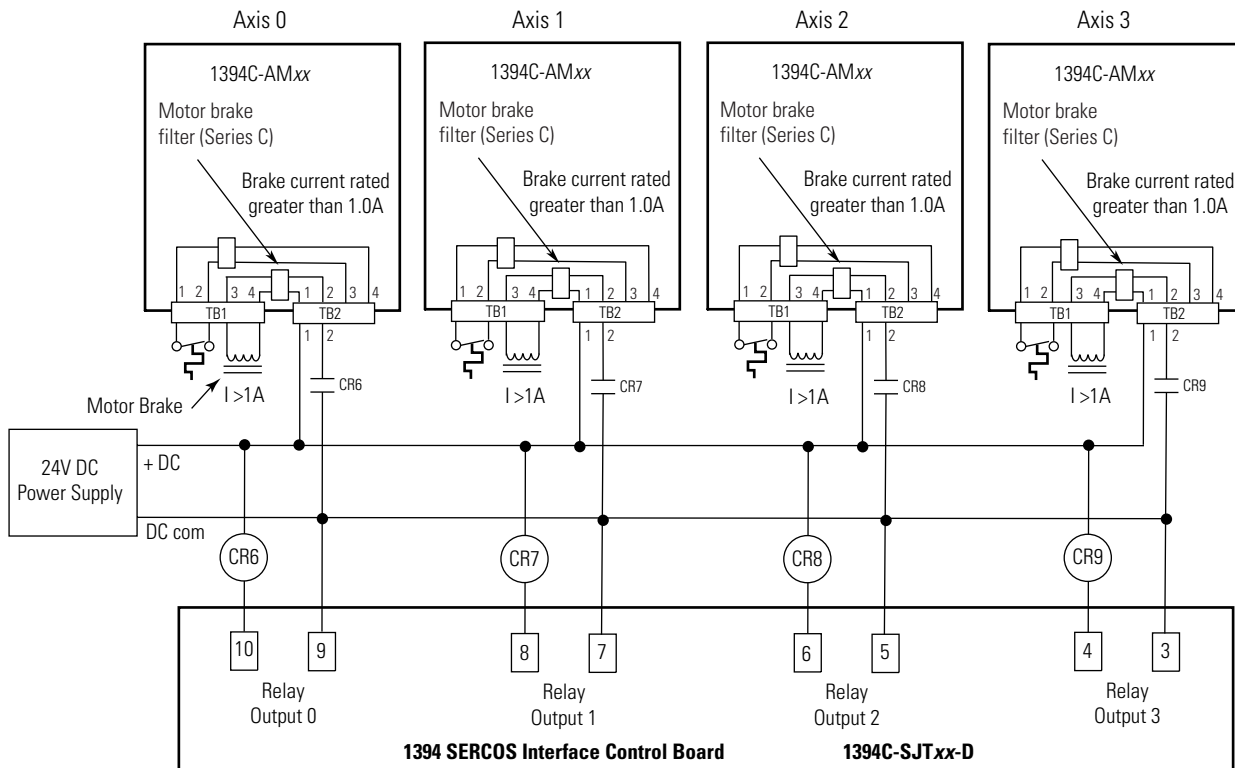

Note: Refer to Figure 1.3 for the location of the TB1/TB2 connectors and pin-out diagram.

Note: Refer to figures 1.1 and 1.2 for the location of the 10-pin relay output connector.



The example below shows 1394 Series B axis modules without internal brake filtering. Any axis connected to a motor with a brake requires a separate pilot relay for noise isolation.

**Figure A.15**  
**Isolated Brake (with pilot relay) Interconnect Diagram**

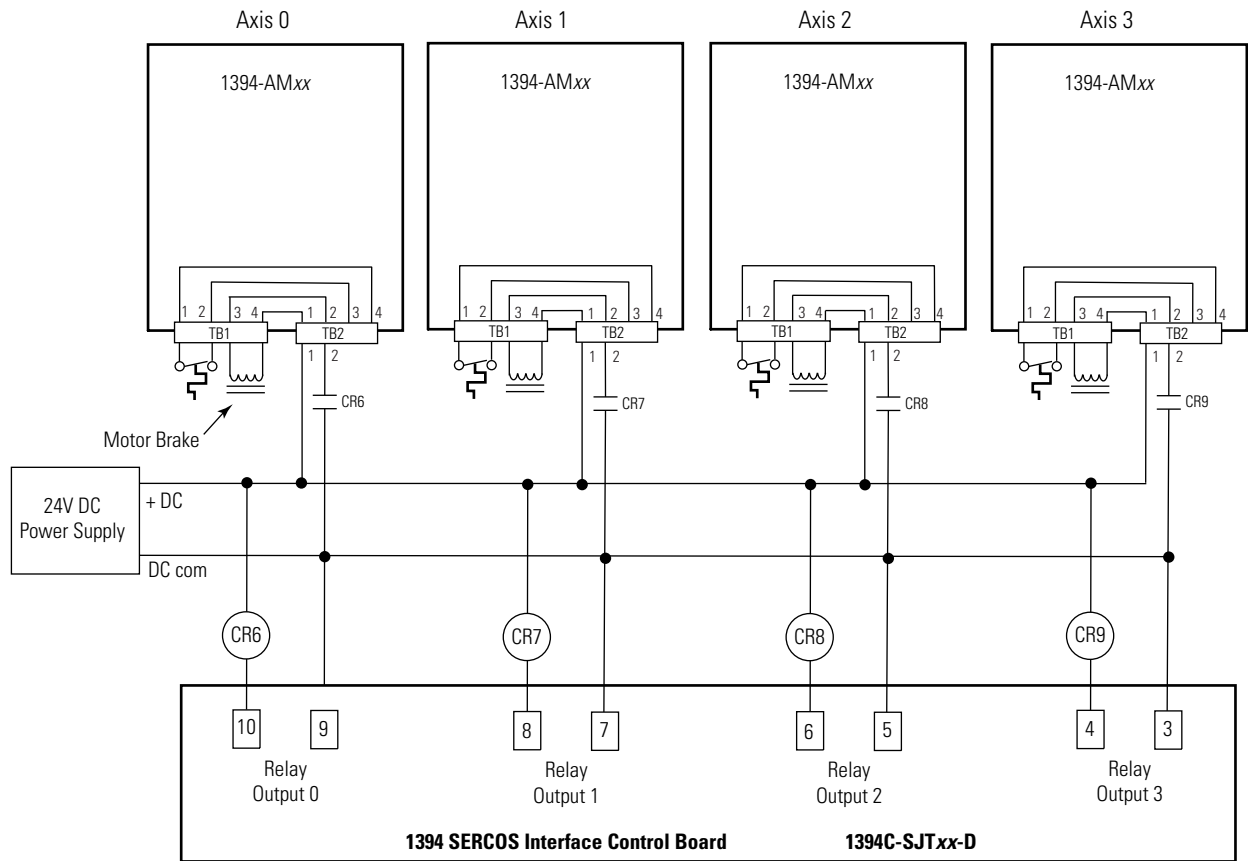

Note: Refer to Figure 1.3 for the location of the TB1/TB2 connectors and pin-out diagram.

Note: Refer to figures 1.1 and 1.2 for the location of the 10-pin relay output connector.



**Numerics**

1326AB (M2L/S2L)  
interconnect diagram A-7  
1326AS  
interconnect diagram A-8  
1394 SERCOS  
commissioning 1-1  
configuring 1-7  
1394 system  
troubleshooting 2-1  
1756-MxxSE P-1  
1756-MxxSE interface module  
1-7  
1784-PM16SE P-1  
1784-PM16SE PCI card 1-7

**A**

analog connector 2-20  
analog test points 2-20  
applying power  
24V 1-20  
360/480V 1-21  
attribute tab 1-17  
axis assignment tab 1-17  
axis module  
connector designators 1-3, 1-6  
installing replacement 2-25  
removing 2-24  
status LED 2-4  
axis module status LED 1-21,  
1-22  
axis properties 1-18

**B**

base node address 1-8, 1-15  
baud rate 1-10  
bus regulator 1-16

**C**

cables  
fiber-optic cable length 1-7  
certifications  
Rockwell Automation Product  
Certification P-2  
changing parameters 2-18  
comments regarding this manual  
P-4  
commissioning 1-1  
configuring

1394 SERCOS 1-7  
Logix 1-11  
optical power level 1-10  
connector  
analog 2-20  
relay 2-20  
connector designators  
axis module 1-3  
system module 1-3  
connector locations  
axis module 1-6  
Logix 1-7  
system module 1-4, 1-5  
contents of manual P-2  
controller properties 1-11  
ControlLogix P-1  
ControlLogix Motion Module  
Setup and Configuration  
Manual 1-11, 1-22  
conventions used in this manual  
P-3  
conversion tab 1-18  
cycle time 1-14

**D**

data rate 1-14  
data type 1-15  
date and time tab 1-12  
detecting a problem 2-2  
digital output settings 2-22  
dip switches 1-14  
disable drive 2-14  
documentation P-2  
download program 1-19  
drive system ok 2-22  
drive tab 1-18  
DriveExplorer 2-18

**F**

fault actions tab 1-19  
fault behavior 2-14  
faults  
axis module  
+hard ovtrvl 2-10  
+soft ovtrvl 2-10  
ATune Flt 2-9  
Aux Fdbk AQB 2-9  
Aux Fdbk Loss 2-9  
Aux Fdbk Noise 2-9  
axis hookup fault 2-9

- axis unknown 2-9
  - Bus Loss 2-9
  - desat 2-9
  - drive enable 2-9
  - Follow Error 2-10
  - hard ovrtrvl 2-10
  - I(t) Fault 2-10
  - Motor Overtemp 2-11
  - Mtr Fdbk AQB 2-10
  - Mtr Fdbk comm 2-9, 2-10
  - Mtr Fdbk Loss 2-10
  - Mtr Fdbk Noise 2-11
  - Overspeed 2-11
  - Overtemp 2-11
  - Power Fault 2-11
  - soft ovrtrvl 2-10
  - axis module (Logix)
    - AuxFeedback 2-9
    - AuxFeedbackNoise 2-9
    - DriveEnableInput 2-9
    - DriveHard 2-9
    - DriveOvercurrent 2-9, 2-10, 2-11
    - DriveOvertemp 2-11
    - DriveUndervoltage 2-9
    - MotFeedback 2-10
    - MotFeedbackNoise 2-11
    - MotorOvertemp 2-11
    - NegHardOvertravel 2-10
    - NegSoftOvertravel 2-10
    - OverSpeed 2-11
    - PosHardOvertravel 2-10
    - PositionError 2-10
    - PosSoftOvertravel 2-10
  - system module
    - bus overcurrent 2-6
    - Bus Overvoltage 2-6
    - Bus Precharge 2-6
    - Bus Undervoltage 2-6
    - Can Init 2-6
    - contactor fault 2-7
    - Fdbk Watch Dog 2-7
    - Ground Short 2-7
    - IDMA load 2-7
    - Memory Init 2-7
    - NV Mem Init 2-7
    - Objects Init 2-7
    - Phase Loss Flt 2-7
    - SCANport Comm 2-7
    - SERCOS Init 2-7
    - SERCOS ring flt 2-7
    - SERCOS same address 2-8
    - Serial Ring Init 2-7
    - shunt time out 2-8
    - sys mod unknown 2-8
    - Sys Overtemp 2-8
    - task Init 2-8
    - unknown fault 2-8
  - system module (Logix)
    - DriveHard 2-6, 2-7, 2-8
    - DriveOvercurrent 2-6
    - DriveOvertemp 2-8
    - DriveOvervoltage 2-6, 2-8
    - DriveUndervoltage 2-6
    - GroundShort 2-7
    - MotFeedback 2-7
    - PowerPhaseLoss 2-7
    - SERCOS 2-7
    - SERCOSFault 2-8
  - feedback tab 1-18
  - fiber-optic cables
    - receive and transmit connectors 1-7
- ## H
- HIM 2-18
    - programming flowchart 2-19
  - hookup tab 1-23
  - human interface module (HIM) 2-18
- ## I
- interconnect diagrams
    - 1326AB (M2L/S2L) A-7
    - 1326AS A-8
  - motor brake
    - Series B axis modules A-17
    - Series C axis modules A-15, A-16
  - MP-Series low inertia A-6
  - notes A-2
  - power A-3
  - shunt module A-4, A-5
  - thermal switch
    - Series A and B axis modules A-12, A-13
    - Series C axis modules A-10, A-11

**L**

LED  
axis module status 1-21, 1-22, 2-4  
network status 1-20, 2-5  
SERCOS module 1-20  
system module status 1-20, 1-22, 2-3  
local support P-4  
Logix  
connector designators 1-7  
Logix interface module 1-11  
loop configuration 1-18

**M**

manuals on-line P-4  
modules  
installing replacement axis 2-25  
installing replacement system 2-27  
removing axis 2-24  
removing system 2-26  
Motion Book Servo Sizing CD P-2  
motion control problem report form P-4  
Motion Control Selection Guide P-2  
motion group properties 1-17  
motor and feedback tab 1-18  
motors  
testing 1-22  
tuning 1-22  
MP-Series low inertia  
interconnect diagram A-6

**N**

network status LED 1-20  
node address switches  
configuring  
base node address 1-8  
baud rate 1-10  
noise P-2

**O**

optical power level 1-10, 1-14

**P**

parameters, changing 2-18  
power  
control 24V 1-20  
input 1-21  
interconnect diagrams A-3  
precautions  
general startup 1-2  
safety 2-2  
problem report form P-4

**R**

receiving and storage P-3  
related documentation  
Motion Book Servo Sizing CD P-2  
relay connector 2-20  
RSLogix 5000 software 1-11, 2-18

**S**

safety precautions 2-2  
SERCOS module LED 1-20  
shunt module  
configuring 1-16  
interconnect diagram A-4, A-5  
shutdown 2-14  
SoftLogix P-1  
SoftLogix Motion Card Setup and Configuration Manual 1-11, 1-22  
software  
RSLogix 5000 1-11, 2-18  
status LEDs 1-22  
status only 2-14  
stop motion 2-14  
storage P-3  
supplemental troubleshooting information 2-18  
support  
comments regarding this manual P-4  
local product P-4  
technical product assistance P-4  
switches  
base node address 1-8  
baud rate 1-10  
dip 1-14  
optical power level 1-10, 1-14

System Design for Control of  
Electrical Noise Reference  
Manual P-2

system module

- connector designators 1-3
- connector locations 1-4, 1-5
- installing a replacement 2-27
- removing 2-26

system module status LED 1-20,  
1-22, 2-3

## T

technical product assistance P-4

testing axes

- hookup tab 1-23

testing motors 1-22

troubleshooting 2-1

- axis module faults 2-9

- axis module status LED 2-4

- disable drive 2-14

- fault behavior 2-14

- general system problems 2-12

- how to detect a problem 2-2

- network status LED 2-5

- shutdown 2-14

- status only 2-14

- stop motion 2-14

- supplemental troubleshooting  
information 2-18

  - changing digital output  
settings 2-22

  - changing parameters  
2-18

  - using analog test points  
2-20

- system module faults 2-6

- system module status LED 2-3

tune tab 1-26

tuning axes

- tune tab 1-26

tuning motors 1-22

## U

understanding

- motor brake A-14

- motor thermal switches A-9

units tab 1-18

For more information refer to our web site: [www.ab.com/motion](http://www.ab.com/motion)

For Rockwell Automation Technical Support information refer to: [www.rockwellautomation.com/support](http://www.rockwellautomation.com/support) or Tel: (1) 440.646.3434

**[www.rockwellautomation.com](http://www.rockwellautomation.com)**

---

### **Power, Control and Information Solutions Headquarters**

Americas: Rockwell Automation, 1201 South Second Street, Milwaukee, WI 53204-2496 USA, Tel: (1) 414.382.2000, Fax: (1) 414.382.4444

Europe/Middle East/Africa: Rockwell Automation, Vorstlaan/Boulevard du Souverain 36, 1170 Brussels, Belgium, Tel: (32) 2 663 0600, Fax: (32) 2 663 0640

Asia Pacific: Rockwell Automation, Level 14, Core F, Cyberport 3, 100 Cyberport Road, Hong Kong, Tel: (852) 2887 4788, Fax: (852) 2508 1846

Publication 1394-IN024B-EN-P — February 2004

Supersedes Publication 1394-IN024A-EN-P — July 2001

Copyright © 2004 Rockwell Automation. All rights reserved. Printed in USA.